

SYM.	DATE	CHANGE DESCRIPTION	DWN.
A	02/01	CHANGED 123008-EQ4 TO EX4	RH

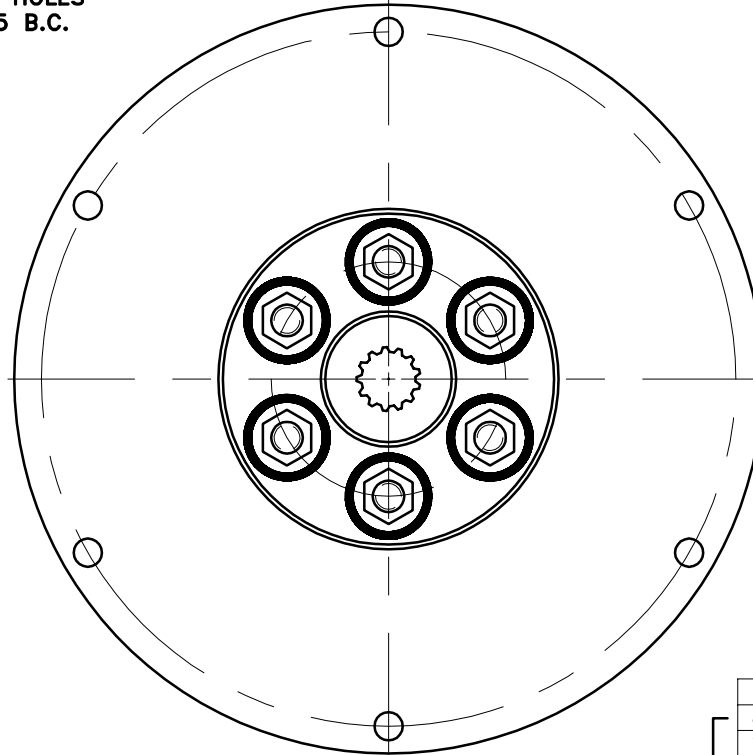
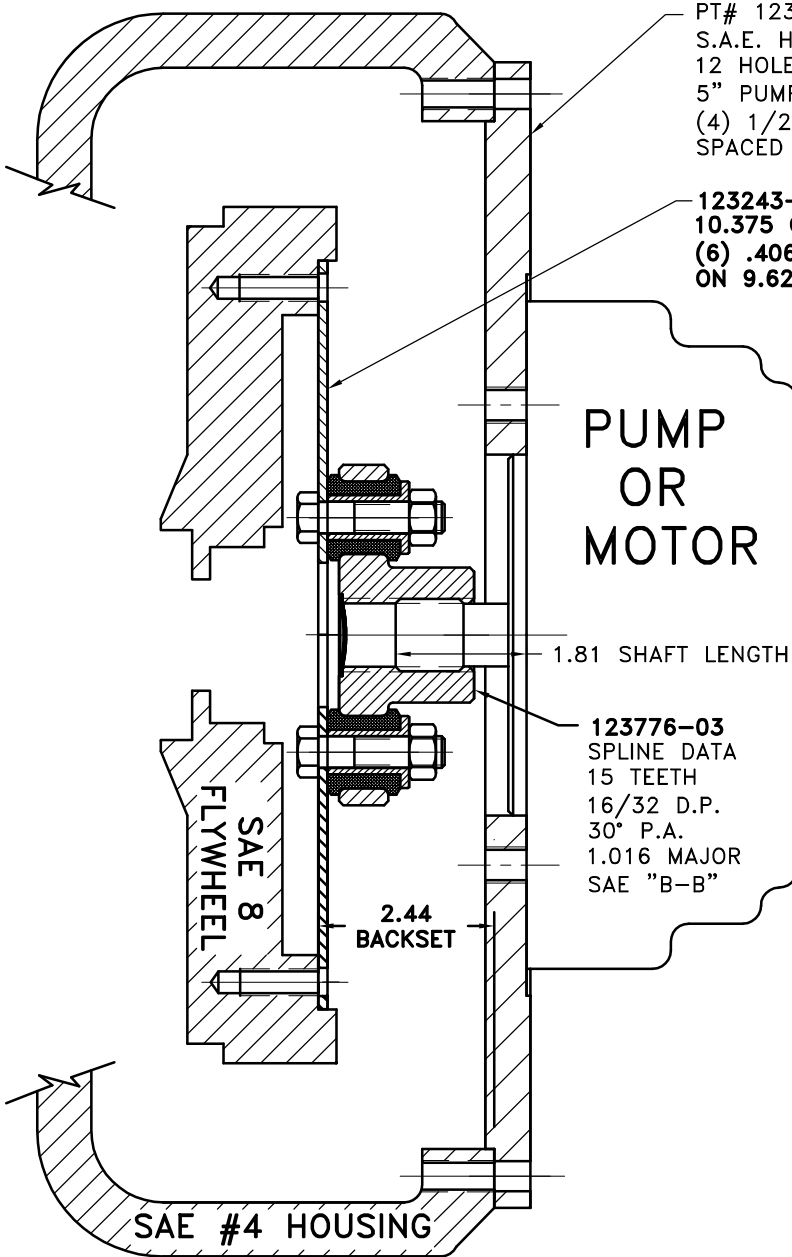

COUPLING ASS'Y
#123294

UP TO 65 HP

QTY.	PART NUMBER	DESCRIPTION
1	123008-EX4	PUMP MOUNT PLATE
1	801912	GREASE
1	HP-1125-S-32	HUBBARD PLUG
6	N250	7/16-20 NUT
6	HX230	7/16-20x1-3/4 HHB
6	123000-00	STEEL BUSHING
6	H62500	NEOPRENE INSERT
1	123776-03	COUPLING HUB
1	123243-10	FLYWHEEL PLATE

SYMBOLS	DET.	PART NUMBER	DESCRIPTION	QTY.
▨ FLATNESS — STRAIGHTNESS ∠ ANGULARITY ⊥ SQUARENESS ∥ PARALLELISM ⊕ CONCENTRICITY ⊙ TRUE POSITION ○ ROUNDNESS ⊖ CIRCULAR RUN OUT ⊖ TOTAL RUN OUT ⊖ CYLINDRICITY √ FINISH	DO NOT SCALE DRAWING			
	TOLERANCES UNLESS OTHERWISE SPECIFIED			
	ANGLE ±1/2°			
	FRACTION ±1/32			
	DECIMAL			
	.00 ±.01			
	.000 ±.005			
	.0000 ±.0005			
	- UNLESS OTHERWISE SPECIFIED - REMOVE FIRST THREAD ON ALL TAPPED HOLES			
	BREAK ALL SHARP CORNERS .010 TO .020 STAMP OR MARK DRAWING NO.			
		TITLE FLYWHEEL COUPLING ASS'Y W/ PUMP MOUNT PLATE		
		MATERIAL		
		DRAWN BY HAVEMAN	DATE 6-21-00	DRAWING NO. 125968
		CHECKED BY SCALE		SHEET OF REV. 12 OF 12

THIS DRAWING IS THE PROPERTY OF HAYES MFG. INC. AND IS LOANED SUBJECT TO THE CONDITION THAT IT SHALL NOT BE REPRODUCED, COPIED, LOANED OR OTHERWISE DISPOSED OF, DIRECTLY OR INDIRECTLY. IT SHALL BE USED AS A MEANS OF REFERENCE TO WORK FURNISHED BY THIS COMPANY ONLY AND IS NOT TO BE SUBMITTED TO OUTSIDE PARTIES FOR EXAMINATION WITHOUT OUR CONSENT.