

PT# 123008-CO2
 SAE HOUSING MOUNT
 27/64 DRILL THRU 12 HOLES
 EQUALLY SPACED ON 18.38 B.C.
 SAE "B" PUMP MOUNT. 4" PUMP PILOT.
 (2) 1/2-13 TAPPED HOLES EQUALLY
 SPACED ON 5.75 B.C.

123243-37
 13.874 O.D.
 (8) .406 HOLES
 ON 13.125 B.C.

PUMP
 OR
 MOTOR

123214-17
 SPLINE DATA
 15 TEETH
 16/32 D.P.
 30° P.A.
 1.016 MAJOR
 SAE "B-B"

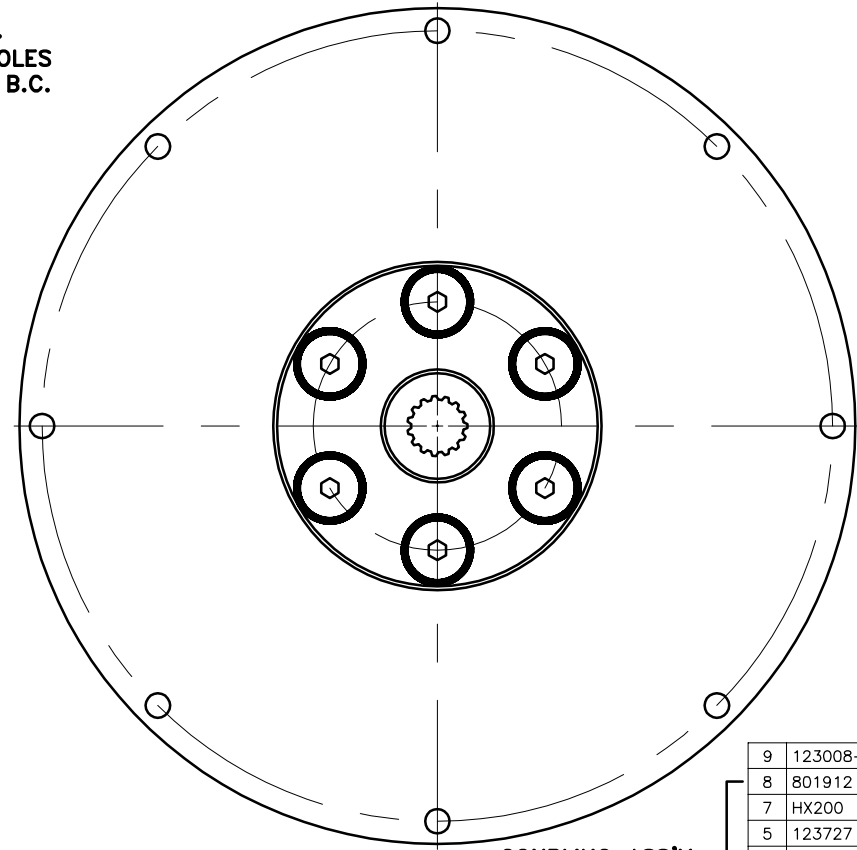

COUPLING ASS'Y
 #123091

UP TO 120 HP

9	123008-CO2	PUMP MOUNT PLATE	1
8	801912	GREASE	1
7	HX200	7/16-20x1 HHB	6
5	123727	THREADED BUSHING	6
4	H62500	NEOPRENE INSERT	6
3	123214-17	COUPLING HUB	1
2	124623	BACKING PLATE	1
1	123243-37	FLYWHEEL PLATE	1

SYMBOLS	DET.	PART NUMBER	DESCRIPTION	QTY.
▨ FLATNESS — STRAIGHTNESS ∠ ANGULARITY ⊥ SQUARENESS ∥ PARALLELISM ⊙ CONCENTRICITY ⊕ TRUE POSITION ○ ROUNDNESS ⊖ CIRCULAR RUN OUT ⊘ TOTAL RUN OUT ∅ CYLINDRICITY ✓ FINISH	DO NOT SCALE DRAWING TOLERANCES UNLESS OTHERWISE SPECIFIED ANGLE ±1/2° FRACTION ±1/32 DECIMAL .00 ±.01 .000 ±.005 .0000 ±.0005			
- UNLESS OTHERWISE SPECIFIED - REMOVE FIRST THREAD ON ALL TAPPED HOLES BREAK ALL SHARP CORNERS .010 TO .020 STAMP OR MARK DRAWING NO.		DRAWN BY HAVEMAN	DATE 11-20-00	DRAWING NO. 126109 SHEET OF REV.

THIS DRAWING IS THE PROPERTY OF HAYES MFG. INC. AND IS LOANED SUBJECT TO THE CONDITION THAT IT SHALL NOT BE REPRODUCED, COPIED, LOANED OR OTHERWISE DISPOSED OF, DIRECTLY OR INDIRECTLY. IT SHALL BE USED AS A MEANS OF REFERENCE TO WORK FURNISHED BY THIS COMPANY ONLY AND IS NOT TO BE SUBMITTED TO OUTSIDE PARTIES FOR EXAMINATION WITHOUT OUR CONSENT.