

REV	DATE	CHANGE DESCRIPTION	MOD. BY	CK1	CK2

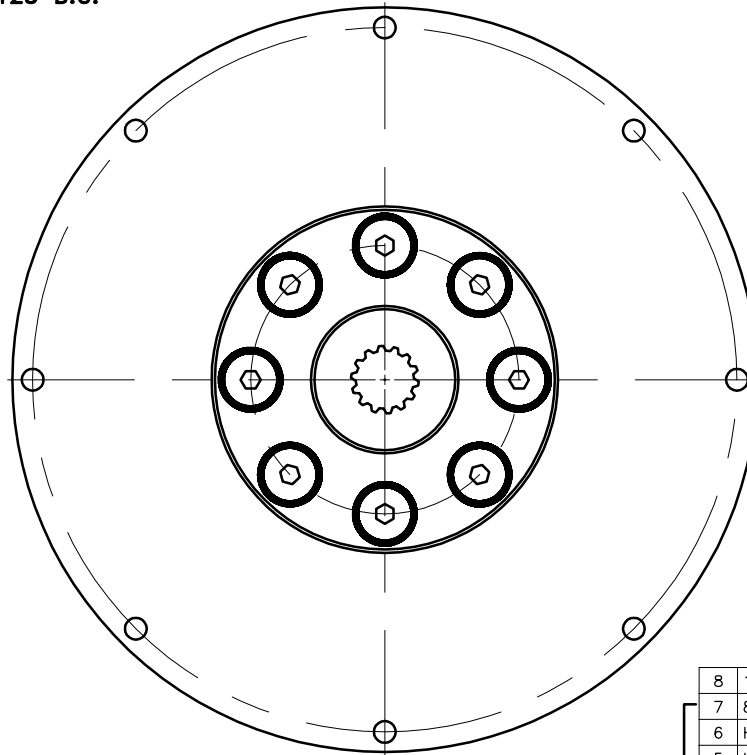
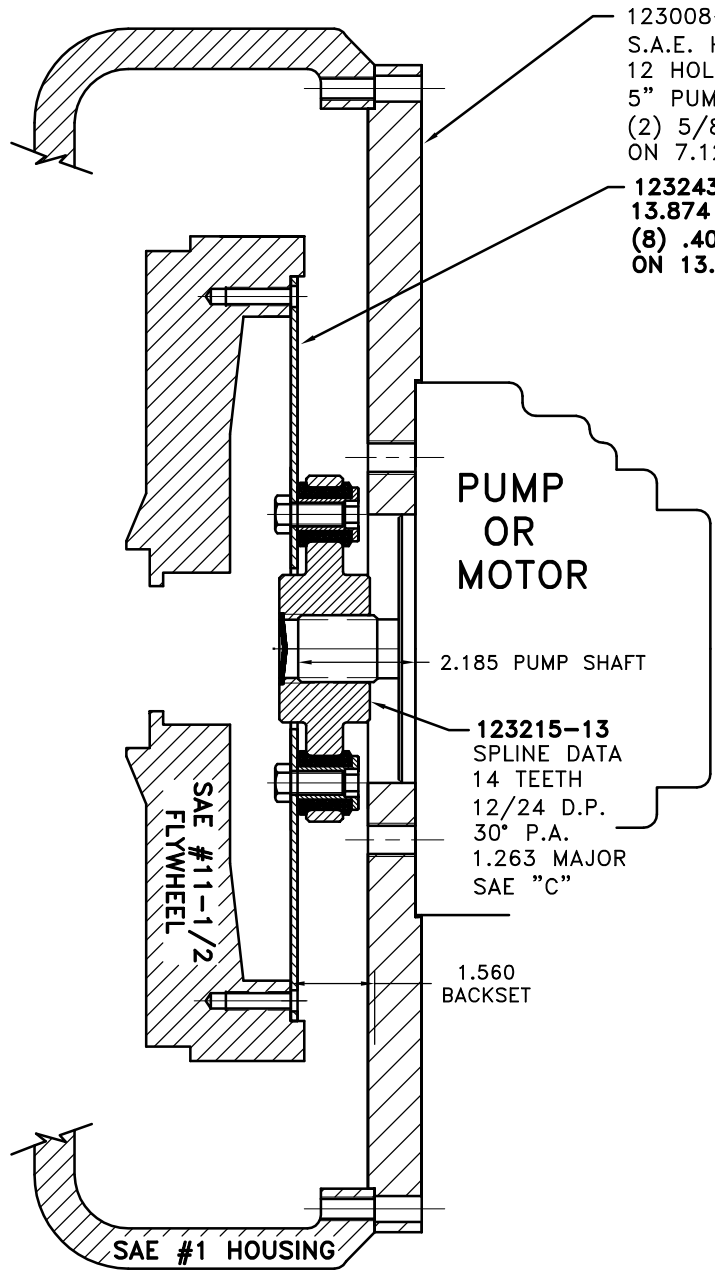

COUPLING ASS'Y
#123720

UP TO 150 HP

QTY.	PART NUMBER	DESCRIPTION
1	123008-AX2	PUMP MOUNT PLATE
1	801912	GREASE
1	HP-1312-S-62	HUBBARD PLUG
8	HX200	7/16-20x1 HHB
8	123727	THREADED BUSHING
8	H62500	NEOPRENE INSERT
1	123215-13	COUPLING HUB
1	123243-70	FLYWHEEL PLATE

SYMBOLS	DET.	PART NUMBER	DESCRIPTION	QTY.
▨ FLATNESS — STRAIGHTNESS ∟ ANGULARITY ⊥ SQUARENESS ∥ PARALLELISM ⊕ CONCENTRICITY ⊙ TRUE POSITION ○ ROUNDNESS ⊖ CIRCULAR RUN OUT ⊖ TOTAL RUN OUT ⊖ CYLINDRICITY √ FINISH	DO NOT SCALE DRAWING TOLERANCES UNLESS OTHERWISE SPECIFIED 12/32 MAXIMUM ANGLE ±1/2° FRACTION ±1/32 DECIMAL .00 ±.01 .000 ±.005 .0000 ±.0005			
			TITLE FLYWHEEL COUPLING ASS'Y WITH PUMP MOUNT PLATE MATERIAL	
			DRAWN BY LAWSON	DATE 6-28-01
			CHECKED BY RJH	SCALE
			DRAWING NO. 126365	SHEET OF REV.

THIS DRAWING IS THE PROPERTY OF HAYES MFG. INC. AND IS LOANED SUBJECT TO THE CONDITION THAT IT SHALL NOT BE REPRODUCED, COPIED, LOANED OR OTHERWISE DISPOSED OF, DIRECTLY OR INDIRECTLY. IT SHALL BE USED AS A MEANS OF REFERENCE TO WORK FURNISHED BY THIS COMPANY ONLY AND IS NOT TO BE SUBMITTED TO OUTSIDE PARTIES FOR EXAMINATION WITHOUT OUR CONSENT.