

REV	DATE	CHANGE DESCRIPTION	MOD. BY	CK1	CK2

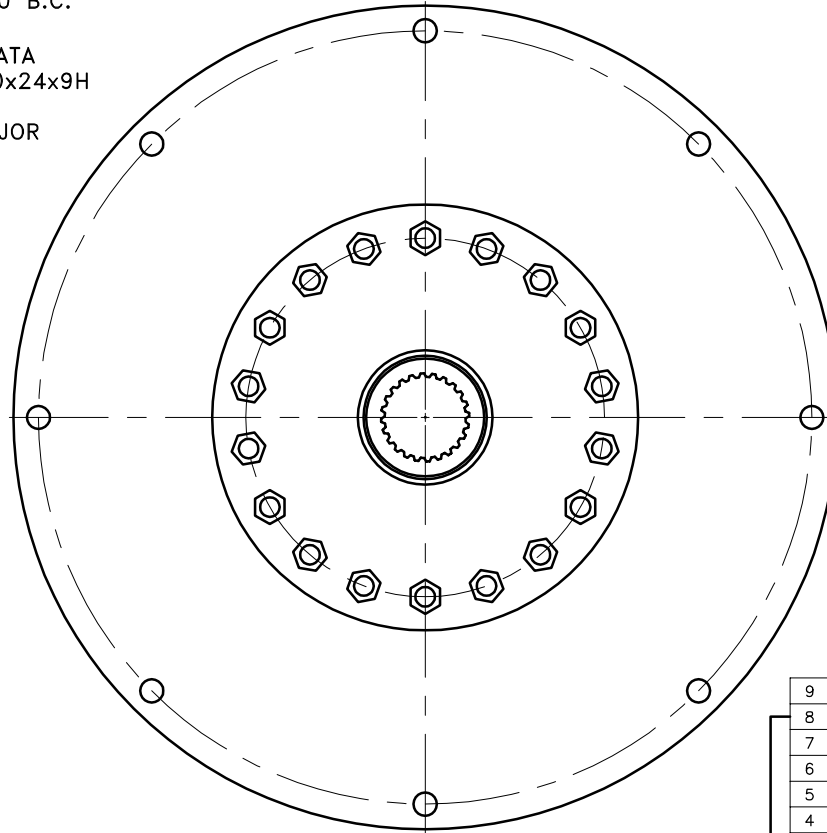
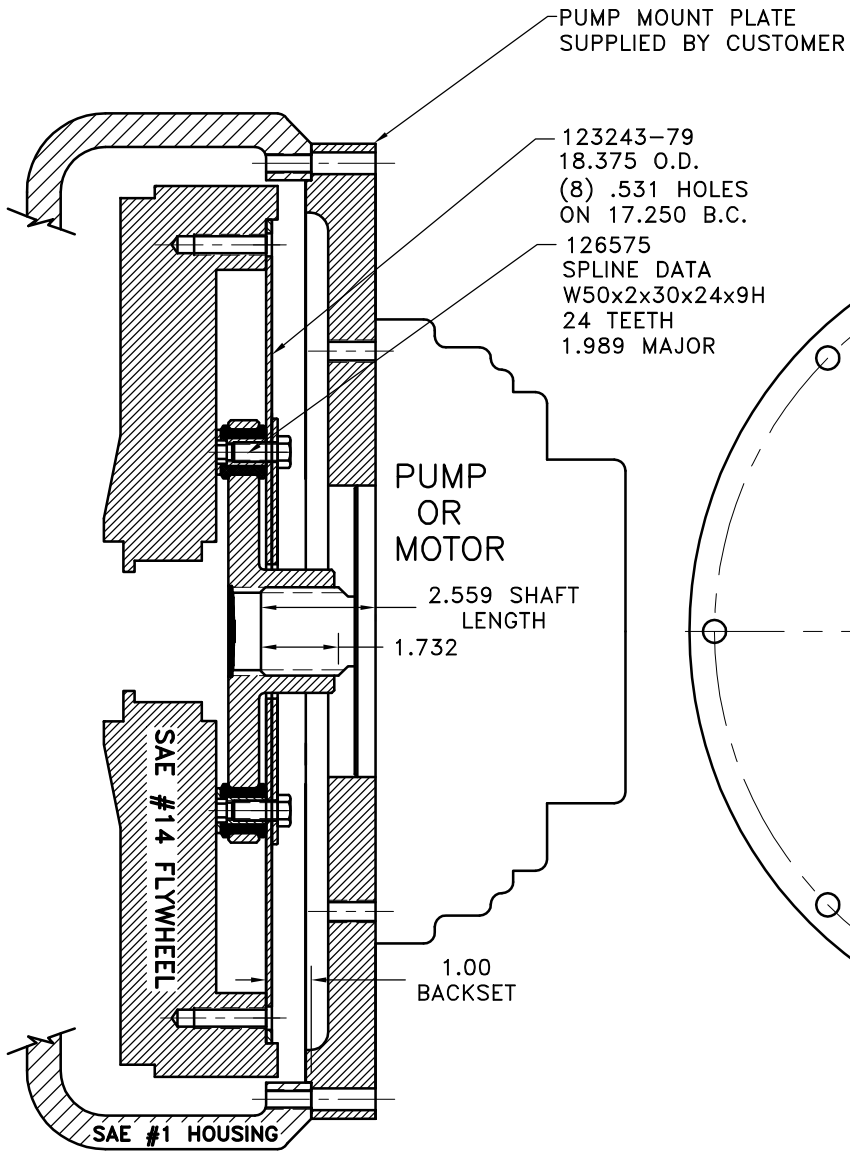

COUPLING ASS'Y #126543

UP TO 450 HP

9	CUSTOMER	PUMP MOUNT PLATE	1
8	801912	GREASE	1
7	HP-2000-S-62	HUBBARD PLUG	1
6	HX200	7/16-20 x 1" HHB	18
5	123727	THREADED BUSHING	18
4	H62500	NEOPRENE INSERT	18
3	126575	COUPLING HUB	1
2	124976	BACKING PLATE	1
1	123243-79	FLYWHEEL PLATE	1

SYMBOLS	DET.	PART NUMBER	DESCRIPTION	QTY.
▭ FLATNESS — STRAIGHTNESS ∟ ANGULARITY ⊥ SQUARENESS ∥ PARALLELISM ⊕ CONCENTRICITY ⊕ TRUE POSITION ○ ROUNDNESS ⊙ CIRCULAR RUN OUT ⊙ TOTAL RUN OUT ∅ CYLINDRICITY ✓ FINISH	DO NOT SCALE DRAWING TOLERANCES UNLESS OTHERWISE SPECIFIED 12/32 MAXIMUM ANGLE ±1/2° FRACTION ±1/32 DECIMAL .00 ±.01 .000 ±.005 .0000 ±.0005			
			TITLE <b>FLYWHEEL COUPLING ASSY WITH PUMP MT. PLATE</b>	
			MATERIAL	
			DRAWN BY SIETING	DATE 11-07-01
			CHECKED BY RJH	SCALE
			DRAWING NO. <b>126542</b>	SHEET OF REV.

THIS DRAWING IS THE PROPERTY OF HAYES MFG. INC. AND IS LOANED SUBJECT TO THE CONDITION THAT IT SHALL NOT BE REPRODUCED, COPIED, LOANED OR OTHERWISE DISPOSED OF, DIRECTLY OR INDIRECTLY. IT SHALL BE USED AS A MEANS OF REFERENCE TO WORK FURNISHED BY THIS COMPANY ONLY AND IS NOT TO BE SUBMITTED TO OUTSIDE PARTIES FOR EXAMINATION WITHOUT OUR CONSENT.