

REV	DATE	CHANGE DESCRIPTION	MOD. BY	CK1	CK2

P/N 123845-09  
 SAE #4 HOUSING MOUNT  
 (12) 27/64 DRILL THRU  
 EQUALLY SPACED ON 15.000 B.C.  
 SAE "C" PUMP MOUNT 5.000 PILOT  
 (2) 5/8-11 TAPPED HOLES  
 EQ. SPACED ON 7.125 B.C.  
 (4) 1/2-13 TAPPED HOLES  
 EQ. SPACED ON 6.375 B.C.

123243-02  
 12.374 O.D.  
 (8) .406 HOLES  
 ON 11.625 B.C.

PUMP  
 OR  
 MOTOR

1.81 SHAFT LENGTH

123776-01  
 SPLINE DATA  
 15 TEETH  
 16/32 D.P.  
 30° P.A.  
 1.016 MAJOR  
 SAE "B-B"

2.125  
 BACKSET

SAE #4 HOUSING

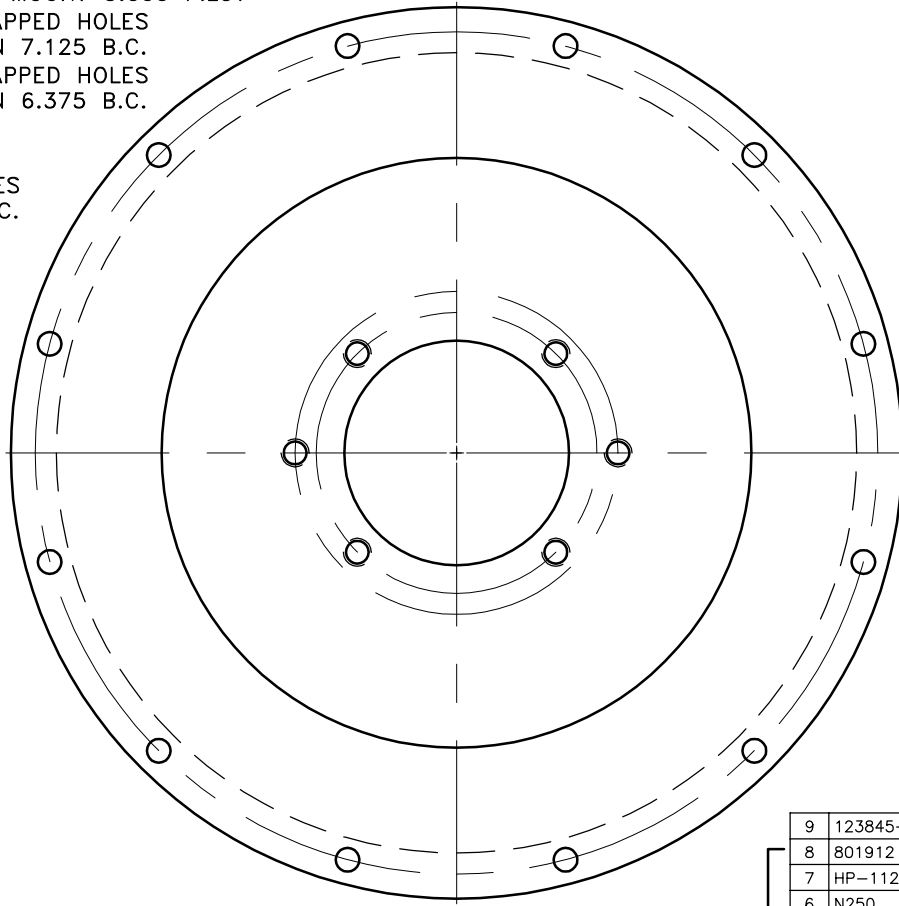

UP TO 65 HP

COUPLING ASS'Y  
 #123968

9	123845-09	PUMP MOUNT PLATE	1
8	801912	GREASE	1
7	HP-1125-S-32	HUBBARD PLUG	1
6	N250	7/16-20 NUT	6
5	HX230	7/16-20x1-3/4 HHB	6
4	123000-00	STEEL BUSHING	6
3	H62500	NEOPRENE INSERT	6
2	123776-01	COUPLING HUB	1
1	123243-20	FLYWHEEL PLATE	1

SYMBOLS	DET.	PART NUMBER	DESCRIPTION	QTY.
▨ FLATNESS — STRAIGHTNESS ∠ ANGULARITY ⊥ PERPENDICULARITY ∥ PARALLELISM ⊙ CONCENTRICITY ⊕ TRUE POSITION ○ ROUNDNESS ⊖ CIRCULAR RUN OUT ⊖ TOTAL RUN OUT ⊖ CYLINDRICITY √ FINISH	DO NOT SCALE DRAWING TOLERANCES UNLESS OTHERWISE SPECIFIED 125 MAXIMUM ANGLE ±1/2° FRACTION ±1/32 DECIMAL .00 ±.01 .000 ±.005 .0000 ±.0005			
TITLE FLYWHEEL COUPLING ASS'Y WITH PUMP MOUNT PLATE				
- UNLESS OTHERWISE SPECIFIED - REMOVE FIRST THREAD ON ALL TAPPED HOLES BREAK ALL SHARP CORNERS .010 TO .020 STAMP OR MARK DRAWING NO.		DRAWN BY SIETING	DATE 11-29-01	DRAWING NO. 126574
		CHECKED BY SCALE	SHEET OF REV.	

THIS DRAWING IS THE PROPERTY OF HAYES MFG. INC. AND IS LOANED  
 SUBJECT TO THE CONDITION THAT IT SHALL NOT BE REPRODUCED,  
 COPIED, LOANED OR OTHERWISE DISPOSED OF, DIRECTLY OR INDIRECTLY.  
 IT SHALL BE USED AS A MEANS OF REFERENCE TO WORK FURNISHED BY  
 THIS COMPANY ONLY AND IS NOT TO BE SUBMITTED TO OUTSIDE PARTIES  
 FOR EXAMINATION WITHOUT OUR CONSENT.