

REV	DATE	CHANGE DESCRIPTION	MOD. BY	CK1	CK2

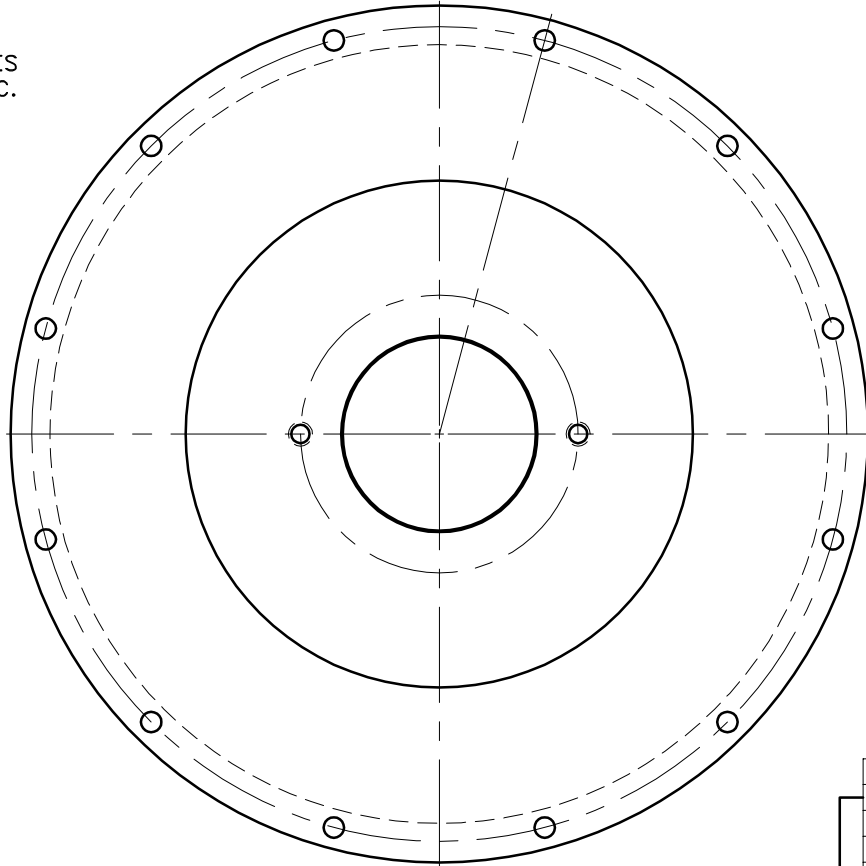
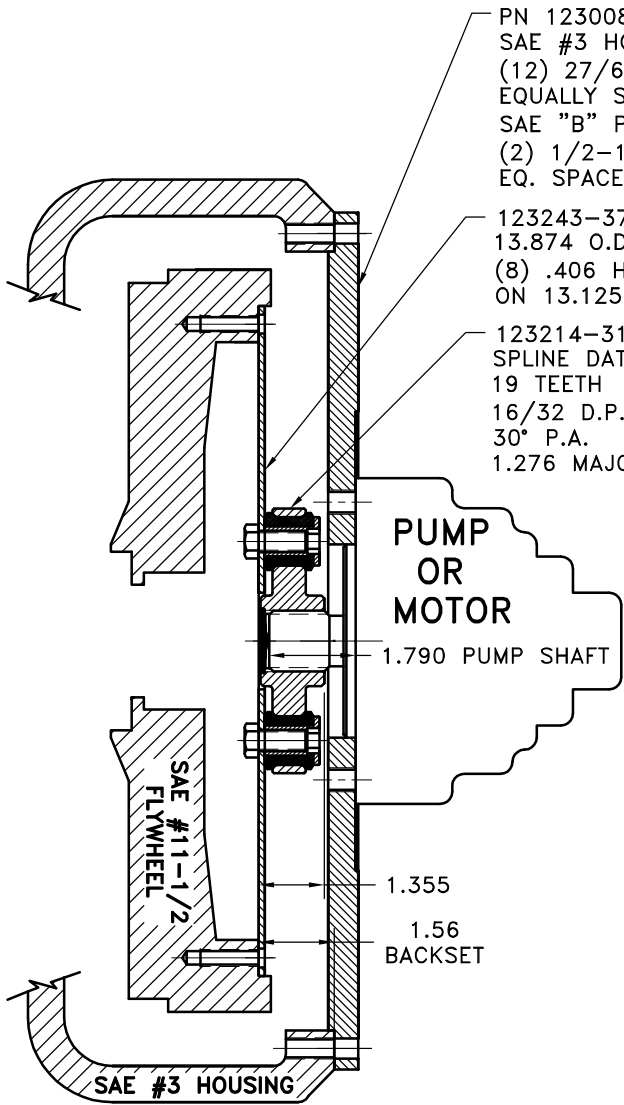

COUPLING ASS'Y #126767

UP TO 110 HP

QTY.	PART NUMBER	DESCRIPTION
1	123008-DO2	PUMP MOUNT PLATE
1	801912	GREASE
1	HP-1312-S-62	HUBBARD PLUG
6	HX200	7/16-20 x 1" HHB
6	123727	THREADED BUSHING
6	H62500	NEOPRENE INSERT
1	123214-31	COUPLING HUB
1	123243-37	FLYWHEEL PLATE

SYMBOLS	DET.	PART NUMBER	DESCRIPTION	QTY.
▨ FLATNESS — STRAIGHTNESS ∠ ANGULARITY ⊥ SQUARENESS ∥ PARALLELISM ⊕ CONCENTRICITY ⊙ TRUE POSITION ○ ROUNDNESS ⊖ CIRCULAR RUN OUT ⊖ TOTAL RUN OUT ∅ CYLINDRICITY ✓ FINISH	DO NOT SCALE DRAWING TOLERANCES UNLESS OTHERWISE SPECIFIED 125/ MAXIMUM ANGLE ±1/2° FRACTION ±1/32 DECIMAL .00 ±.01 .000 ±.005 .0000 ±.0005			
- UNLESS OTHERWISE SPECIFIED - REMOVE FIRST THREAD ON ALL TAPPED HOLES BREAK ALL SHARP CORNERS .010 TO .020 STAMP OR MARK DRAWING NO.		DRAWN BY SIETING	DATE 04-25-02	DRAWING NO. 126760 SHEET OF REV.
		CHECKED BY RJH	SCALE	

THIS DRAWING IS THE PROPERTY OF HAYES MFG. INC. AND IS LOANED SUBJECT TO THE CONDITION THAT IT SHALL NOT BE REPRODUCED, COPIED, LOANED OR OTHERWISE DISPOSED OF, DIRECTLY OR INDIRECTLY. IT SHALL BE USED AS A MEANS OF REFERENCE TO WORK FURNISHED BY THIS COMPANY ONLY AND IS NOT TO BE SUBMITTED TO OUTSIDE PARTIES FOR EXAMINATION WITHOUT OUR CONSENT.