

REV	DATE	CHANGE DESCRIPTION	MOD.BY	CK1	CK2

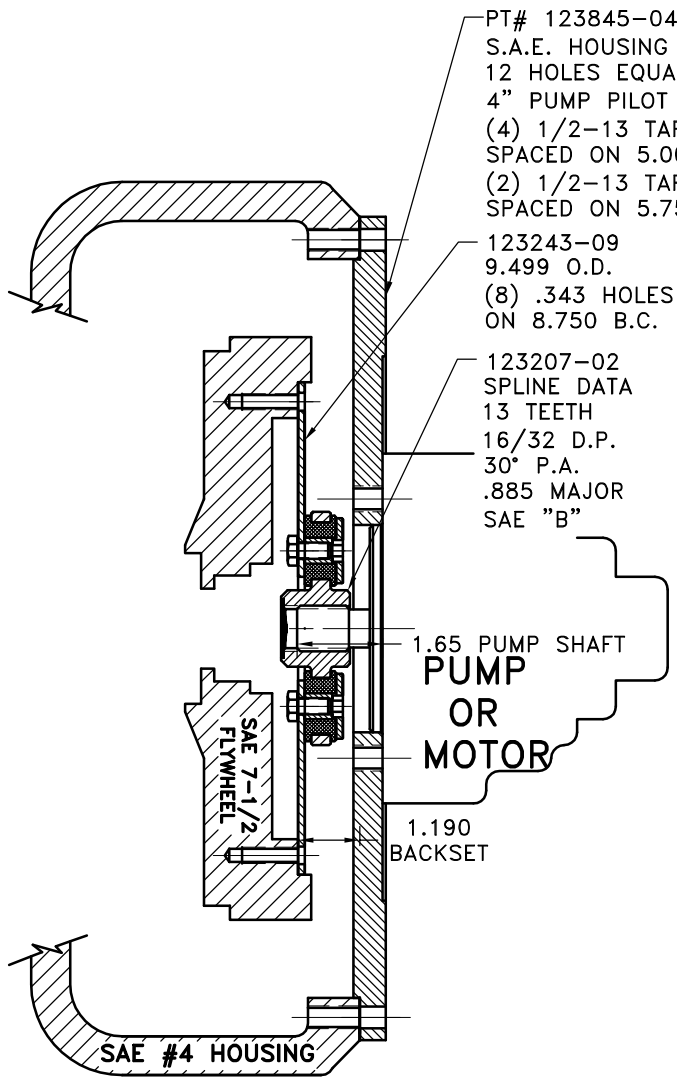

PT# 123845-04
 S.A.E. HOUSING MOUNT 27/64 DRILL THRU
 12 HOLES EQUALLY SPACED ON 15.00 B.C.
 4" PUMP PILOT S.A.E. "B" PUMP MOUNT.
 (4) 1/2-13 TAPPED HOLES EQUALLY
 SPACED ON 5.00 B.C.
 (2) 1/2-13 TAPPED HOLES EQUALLY
 SPACED ON 5.75 B.C.

123243-09
 9.499 O.D.
 (8) .343 HOLES
 ON 8.750 B.C.

123207-02
 SPLINE DATA
 13 TEETH
 16/32 D.P.
 30° P.A.
 .885 MAJOR
 SAE "B"

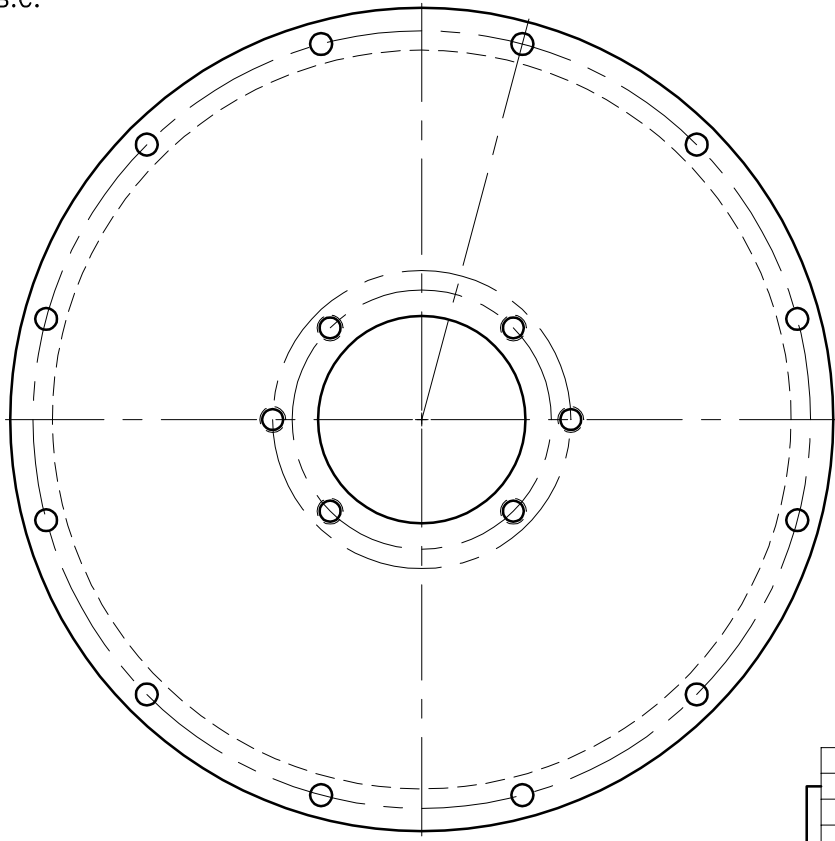

COUPLING ASS'Y #123957

UP TO 50 HP

QTY.	DESCRIPTION	PART NUMBER	REV.
1	FLYWHEEL PLATE	123243-09	1
1	COUPLING HUB	123207-02	1
6	NEOPRENE INSERT	H52500	3
6	THREADED BUSHING	123729-01	4
6	5/16-24 x 5/8" HHB	HX100	5
1	HUBBARD PLUG	HP-1125-S-32	6
1	GREASE	801912	7
1	PUMP MOUNT PLATE	123845-04	8

SYMBOLS	DET.	PART NUMBER	DESCRIPTION	QTY.
▭ FLATNESS — STRAIGHTNESS ∠ ANGULARITY ⊥ SQUARENESS ∥ PARALLELISM ◎ CONCENTRICITY ⊕ TRUE POSITION ○ ROUNDNESS ⊙ CIRCULAR RUN OUT ⊖ TOTAL RUN OUT Ⓢ CYLINDRICITY ✓ FINISH	DO NOT SCALE DRAWING TOLERANCES UNLESS OTHERWISE SPECIFIED 125/ MAXIMUM ANGLE ±1/2° FRACTION ±1/32 DECIMAL .00 ±.01 .000 ±.005 .0000 ±.0005		HAYES MANUFACTURING INC. ® TITLE FLYWHEEL COUPLING ASSY WITH PUMP MOUNT PLATE MATERIAL	
- UNLESS OTHERWISE SPECIFIED - REMOVE FIRST THREAD ON ALL TAPPED HOLES BREAK ALL SHARP CORNERS .010 TO .020 STAMP OR MARK DRAWING NO.		DRAWN BY SIETING	DATE 08-05-02	DRAWING NO. 126877 SHEET OF REV.
		CHECKED BY RJH	SCALE	

THIS DRAWING IS THE PROPERTY OF HAYES MFG. INC. AND IS LOANED
 SUBJECT TO THE CONDITION THAT IT SHALL NOT BE REPRODUCED,
 COPIED, LOANED OR OTHERWISE DISPOSED OF, DIRECTLY OR INDIRECTLY.
 IT SHALL BE USED AS A MEANS OF REFERENCE TO WORK FURNISHED BY
 THIS COMPANY ONLY AND IS NOT TO BE SUBMITTED TO OUTSIDE PARTIES
 FOR EXAMINATION WITHOUT OUR CONSENT.