

REV	DATE	CHANGE DESCRIPTION	MOD. BY	CK1	CK2

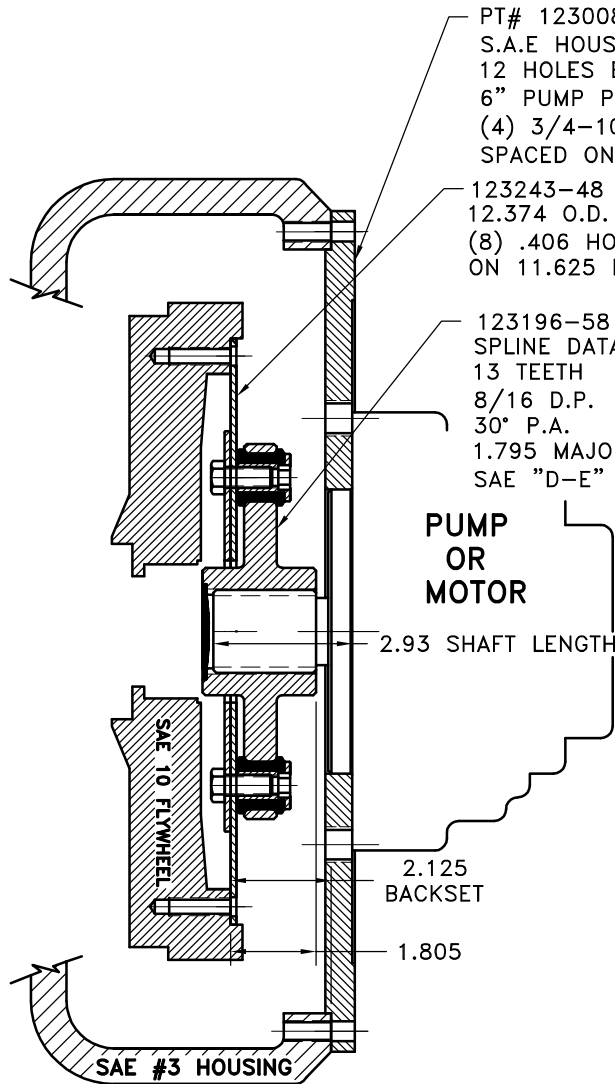

PT# 123008-DS4
 S.A.E HOUSING MOUNT 27/64 DRILL THRU
 12 HOLES EQUALLY SPACED ON 16.88 B.C.
 6" PUMP PILOT S.A.E. "D" PUMP MOUNT.
 (4) 3/4-10 TAPPED HOLES EQUALLY
 SPACED ON 9" B.C.

123243-48
 12.374 O.D.
 (8) .406 HOLES
 ON 11.625 B.C.

123196-58
 SPLINE DATA
 13 TEETH
 8/16 D.P.
 30° P.A.
 1.795 MAJOR
 SAE "D-E"

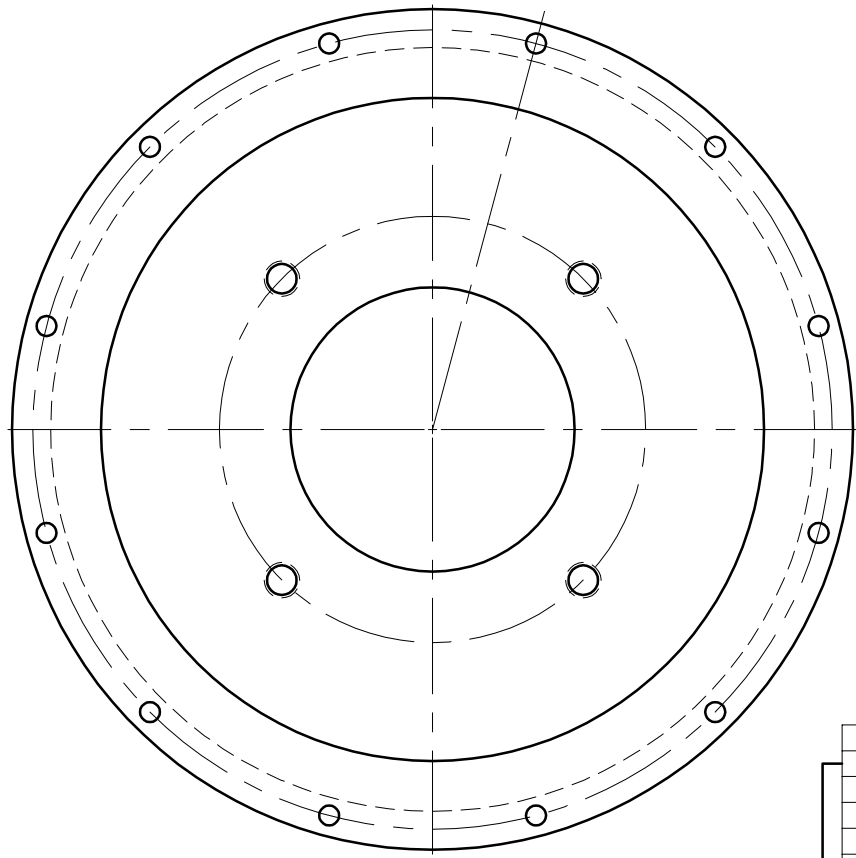

COUPLING ASS'Y #126924

UP TO 350 HP

QTY.	PART NUMBER	DESCRIPTION
1	123008-DS4	PUMP MOUNT PLATE
1	801912	GREASE
1	HP-2000-S-62	HUBBARD PLUG
12	HX200	7/16-20 x 1" HHB
12	123727	THREADED BUSHING
12	H62500	NEOPRENE INSERTS
1	123196-58	COUPLING HUB
1	124961-02	BACKING PLATE
1	123243-48	FLYWHEEL PLATE

THIS DRAWING IS THE PROPERTY OF HAYES MFG. INC. AND IS LOANED SUBJECT TO THE CONDITION THAT IT SHALL NOT BE REPRODUCED, COPIED, LOANED OR OTHERWISE DISPOSED OF, DIRECTLY OR INDIRECTLY. IT SHALL BE USED AS A MEANS OF REFERENCE TO WORK FURNISHED BY THIS COMPANY ONLY AND IS NOT TO BE SUBMITTED TO OUTSIDE PARTIES FOR EXAMINATION WITHOUT OUR CONSENT.

SYMBOLS	DET.	PART NUMBER	DESCRIPTION	QTY.
▨ FLATNESS — STRAIGHTNESS ∠ ANGULARITY ⊥ SQUARENESS ∥ PARALLELISM ⊕ CONCENTRICITY ⊙ TRUE POSITION ○ ROUNDNESS ⊙ CIRCULAR RUN OUT ⊙ TOTAL RUN OUT ∅ CYLINDRICITY ✓ FINISH	DO NOT SCALE DRAWING TOLERANCES UNLESS OTHERWISE SPECIFIED 12/31 MAXIMUM ANGLE ±1/2° FRACTION ±1/32 DECIMAL .00 ±.01 .000 ±.005 .0000 ±.0005			
			TITLE FLYWHEEL COUPLING ASSY WITH PUMP MOUNT PLATE	
			MATERIAL	
			DRAWN BY SIETING	DATE 09-17-02
			CHECKED BY RJH	SCALE
			DRAWING NO. 126923	SHEET OF REV.
			- UNLESS OTHERWISE SPECIFIED - REMOVE FIRST THREAD ON ALL TAPPED HOLES BREAK ALL SHARP CORNERS .010 TO .020 STAMP OR MARK DRAWING NO.	