

REV	DATE	CHANGE DESCRIPTION	MOD. BY	CK1	CK2

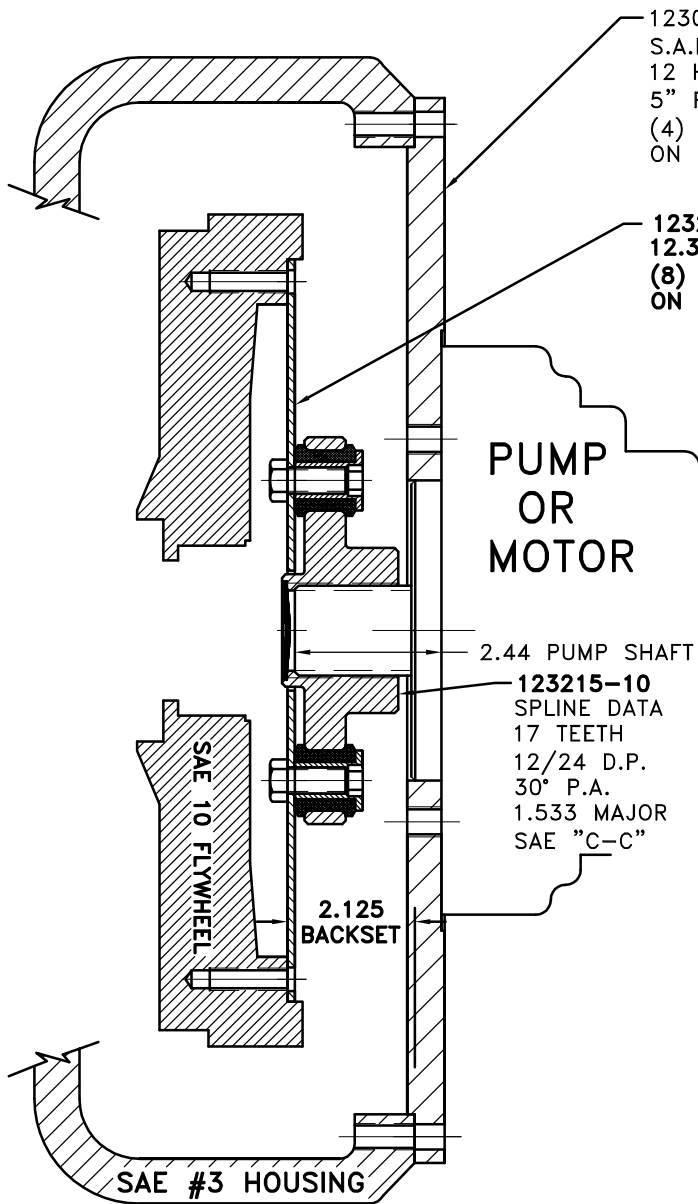

123008-DX4
S.A.E. HOUSING MOUNT 27/64 DIA DRILL THRU
12 HOLES EQUALLY SPACED ON 16.88 B.C.
5" PUMP PILOT S.A.E. "C" PUMP MOUNT
(4) 1/2-13 TAPPED HOLES EQUALLY SPACED
ON 6.38 B.C.

123243-27
12.374 O.D.
(8) .406 HOLES
ON 11.625 B.C.

123215-10
SPLINE DATA
17 TEETH
12/24 D.P.
30° P.A.
1.533 MAJOR
SAE "C-C"

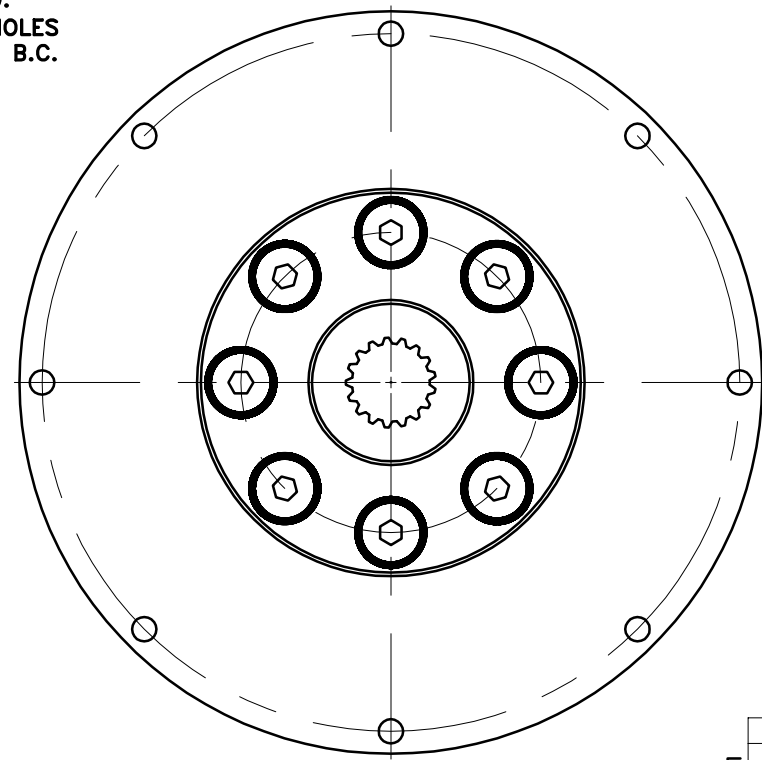

COUPLING ASS'Y
#126955

UP TO 150 HP

REV	DATE	CHANGE DESCRIPTION	MOD. BY	CK1	CK2
8		123008-DX4			1
7		801912			1
6		HP-1625-S-62			1
5		HX200			8
4		123727			8
3		H62500			8
2		123215-10			1
1		123243-27			1

THIS DRAWING IS THE PROPERTY OF HAYES MFG. INC. AND IS LOANED SUBJECT TO THE CONDITION THAT IT SHALL NOT BE REPRODUCED, COPIED, LOANED OR OTHERWISE DISPOSED OF, DIRECTLY OR INDIRECTLY. IT SHALL BE USED AS A MEANS OF REFERENCE TO WORK FURNISHED BY THIS COMPANY ONLY AND IS NOT TO BE SUBMITTED TO OUTSIDE PARTIES FOR EXAMINATION WITHOUT OUR CONSENT.

SYMBOLS	DET.	PART NUMBER	DESCRIPTION	QTY.
▭ FLATNESS — STRAIGHTNESS ∠ ANGULARITY ⊥ SQUARENESS ∥ PARALLELISM ⊙ CONCENTRICITY ⊕ TRUE POSITION ○ ROUNDNESS ⊖ CIRCULAR RUN OUT ⊖ TOTAL RUN OUT ⊖ CYLINDRICITY ✓ FINISH	DO NOT SCALE DRAWING TOLERANCES UNLESS OTHERWISE SPECIFIED 12/32 MAXIMUM ANGLE ±1/2° FRACTION ±1/32 DECIMAL .00 ±.01 .000 ±.005 .0000 ±.0005			
- UNLESS OTHERWISE SPECIFIED - REMOVE FIRST THREAD ON ALL TAPPED HOLES BREAK ALL SHARP CORNERS .010 TO .020 STAMP OR MARK DRAWING NO.		DRAWN BY LAWSON	DATE 10-16-02	DRAWING NO. 126954 SHEET OF REV.