

REV	DATE	CHANGE DESCRIPTION	MOD.BY	CK1	CK2

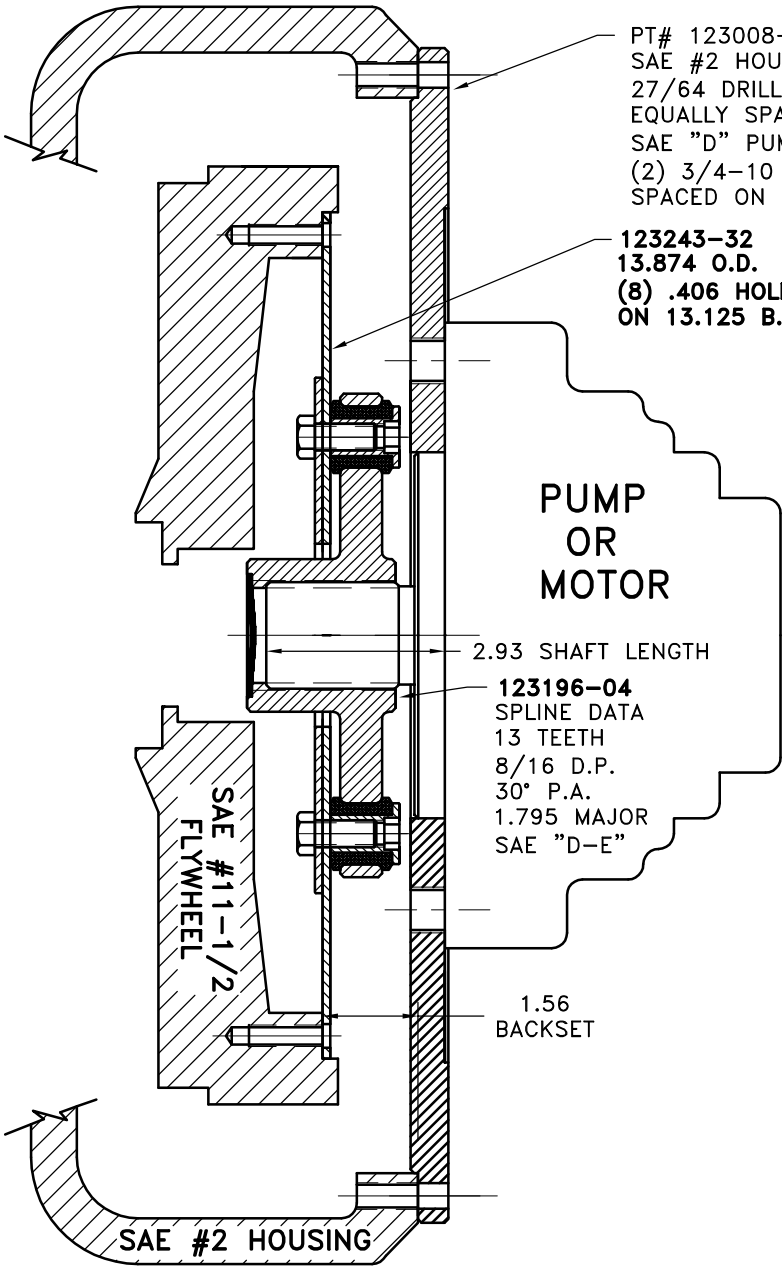

PT# 123008-CS2
 SAE #2 HOUSING MOUNT
 27/64 DRILL THRU 12 HOLES
 EQUALLY SPACED ON 18.38 B.C.
 SAE "D" PUMP MOUNT. 6" PUMP PILOT.
 (2) 3/4-10 TAPPED HOLES EQUALLY
 SPACED ON 9.000 B.C.

123243-32
 13.874 O.D.
 (8) .406 HOLES
 ON 13.125 B.C.

PUMP
 OR
 MOTOR

2.93 SHAFT LENGTH

123196-04
 SPLINE DATA
 13 TEETH
 8/16 D.P.
 30° P.A.
 1.795 MAJOR
 SAE "D-E"

SAE #11-1/2
 FLYWHEEL

1.56
 BACKSET

SAE #2 HOUSING

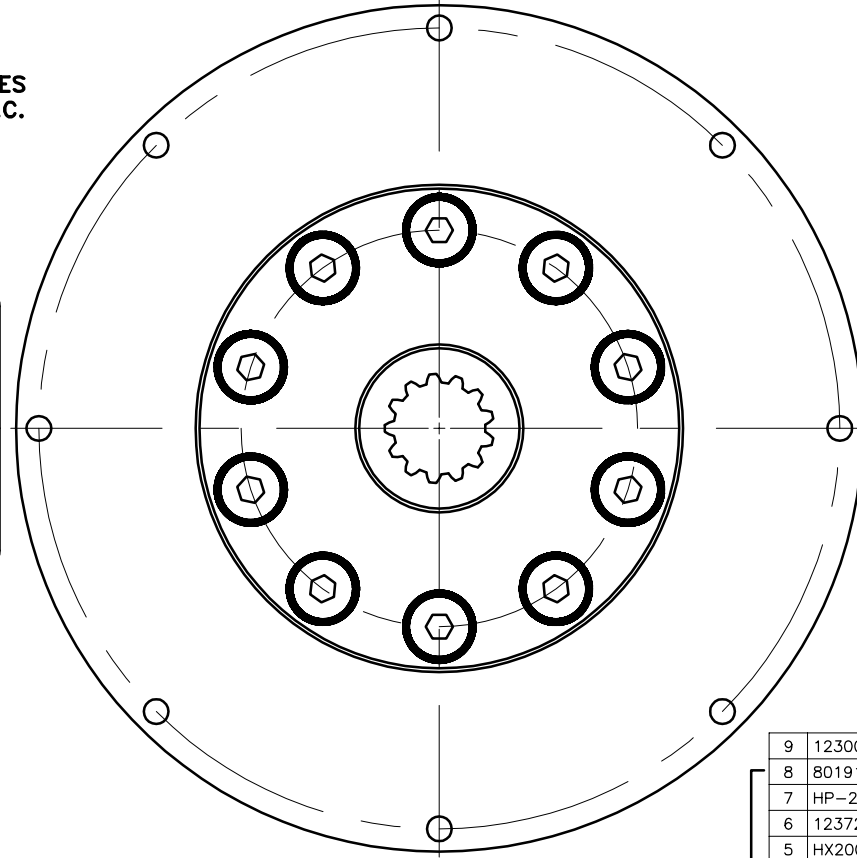

COUPLING ASS'Y
 #123433

UP TO 250 HP

QTY.	PART NUMBER	DESCRIPTION
1	123008-CS2	PUMP MOUNT PLATE
1	801912	GREASE
1	HP-2000-S-62	HUBBARD PLUG
10	123727	THREADED BUSHING
10	HX200	7/16-20x1 HHB
10	H62500	NEOPRENE INSERT
1	123196-04	COUPLING HUB
1	124961-01	BACKING PLATE
1	123243-32	FLYWHEEL PLATE

SYMBOLS	DET.	PART NUMBER	DESCRIPTION	QTY.
▭ FLATNESS — STRAIGHTNESS ∠ ANGULARITY ⊥ SQUARENESS ∥ PARALLELISM ⊙ CONCENTRICITY ⊕ TRUE POSITION ○ ROUNDNESS ⊖ CIRCULAR RUN OUT ⊖ TOTAL RUN OUT ⊖ CYLINDRICITY ✓ FINISH	DO NOT SCALE DRAWING			
	TOLERANCES UNLESS OTHERWISE SPECIFIED			
	ANGLE ±1/2°			
	FRACTION ±1/32			
	DECIMAL			
	.00 ±.01			
	.000 ±.005			
	.0000 ±.0005			
	- UNLESS OTHERWISE SPECIFIED - REMOVE FIRST THREAD ON ALL TAPPED HOLES			
	BREAK ALL SHARP CORNERS .010 TO .020 STAMP OR MARK DRAWING NO.			
		DRAWN BY	DATE	DRAWING NO.
		SIETING	10-21-02	126962
		CHECKED BY	SCALE	SHEET OF REV.
		RJH		126962 OF REV.



TITLE
 PUMP MT PLATE W/ FLYWHEEL COUPLING ASS'Y

MATERIAL

THIS DRAWING IS THE PROPERTY OF HAYES MFG. INC. AND IS LOANED SUBJECT TO THE CONDITION THAT IT SHALL NOT BE REPRODUCED, COPIED, LOANED OR OTHERWISE DISPOSED OF, DIRECTLY OR INDIRECTLY. IT SHALL BE USED AS A MEANS OF REFERENCE TO WORK FURNISHED BY THIS COMPANY ONLY AND IS NOT TO BE SUBMITTED TO OUTSIDE PARTIES FOR EXAMINATION WITHOUT OUR CONSENT.