

REV	DATE	CHANGE DESCRIPTION	MOD. BY	CK1	CK2

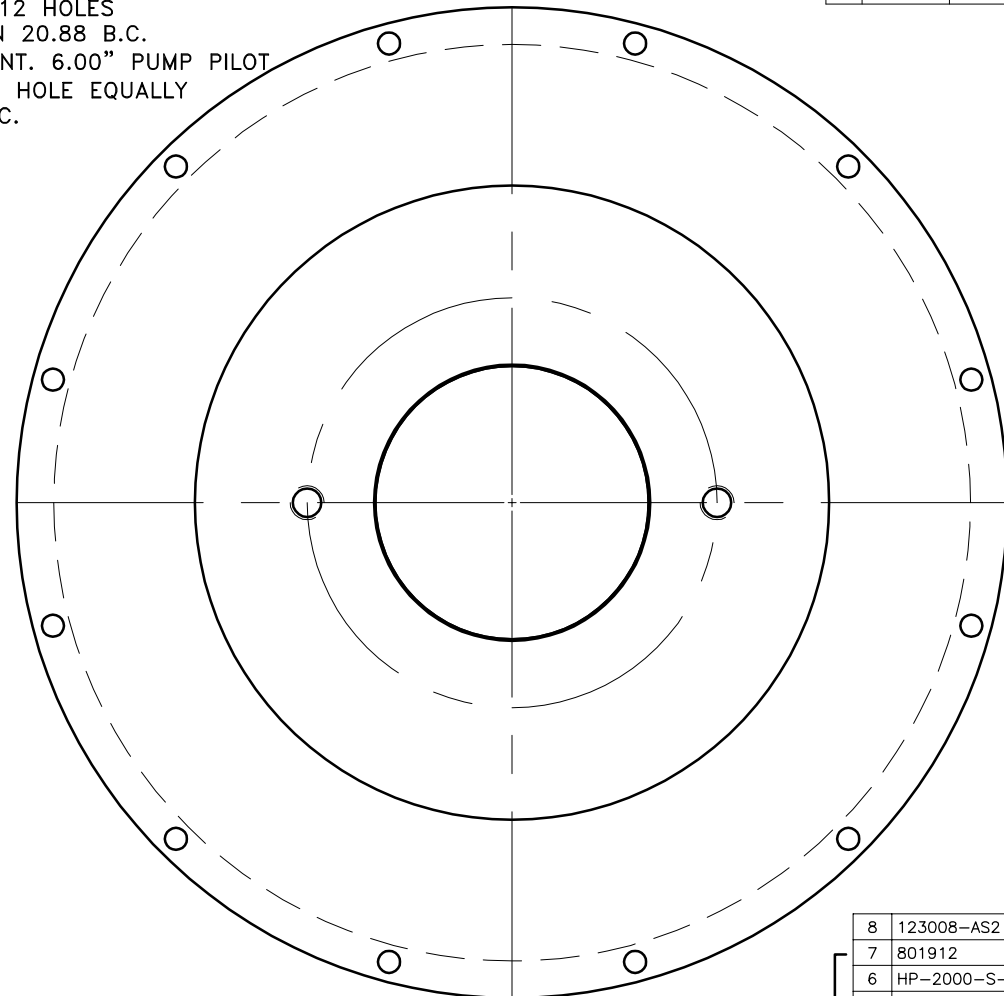
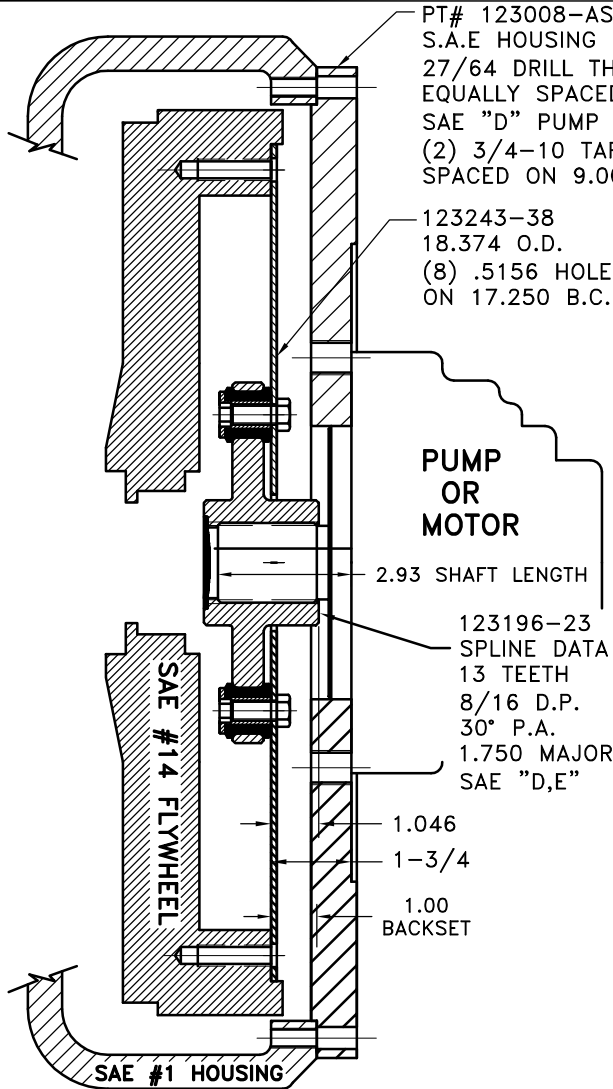

COUPLING ASS'Y
#124270

UP TO 250 HP

REV	DATE	CHANGE DESCRIPTION	MOD. BY	CK1	CK2
8		123008-AS2 PUMP MOUNT PLATE			1
7		801912 GREASE			1
6		HP-2000-S-62 HUBBARD PLUG			1
5		HX200 7/16-20x1 HHB			10
4		123727 THREADED BUSHING			10
3		H62500 NEOPRENE INSERT			10
2		123196-23 COUPLING HUB			1
1		123243-38 FLYWHEEL PLATE			1

SYMBOLS	DET.	PART NUMBER	DESCRIPTION	QTY.
▨ FLATNESS — STRAIGHTNESS ∠ ANGULARITY ⊥ SQUARENESS ∥ PARALLELISM ⊙ CONCENTRICITY ⊕ TRUE POSITION ○ ROUNDNESS ⊖ CIRCULAR RUN OUT ⊘ TOTAL RUN OUT ∅ CYLINDRICITY ✓ FINISH	DO NOT SCALE DRAWING TOLERANCES UNLESS OTHERWISE SPECIFIED 125 MAXIMUM ANGLE ±1/2° FRACTION ±1/32 DECIMAL .00 ±.01 .000 ±.005 .0000 ±.0005			
- UNLESS OTHERWISE SPECIFIED - REMOVE FIRST THREAD ON ALL TAPPED HOLES BREAK ALL SHARP CORNERS .010 TO .020 STAMP OR MARK DRAWING NO.			TITLE FLYWHEEL COUPLING ASSY WITH PUMP MOUNT PLATE MATERIAL	DRAWN BY SIETING CHECKED BY RJH
		DATE 10-24-02 SCALE	DRAWING NO. 126965 SHEET OF REV.	

THIS DRAWING IS THE PROPERTY OF HAYES MFG. INC. AND IS LOANED SUBJECT TO THE CONDITION THAT IT SHALL NOT BE REPRODUCED, COPIED, LOANED OR OTHERWISE DISPOSED OF, DIRECTLY OR INDIRECTLY. IT SHALL BE USED AS A MEANS OF REFERENCE TO WORK FURNISHED BY THIS COMPANY ONLY AND IS NOT TO BE SUBMITTED TO OUTSIDE PARTIES FOR EXAMINATION WITHOUT OUR CONSENT.