

REV	DATE	CHANGE DESCRIPTION	MOD. BY	CK1	CK2

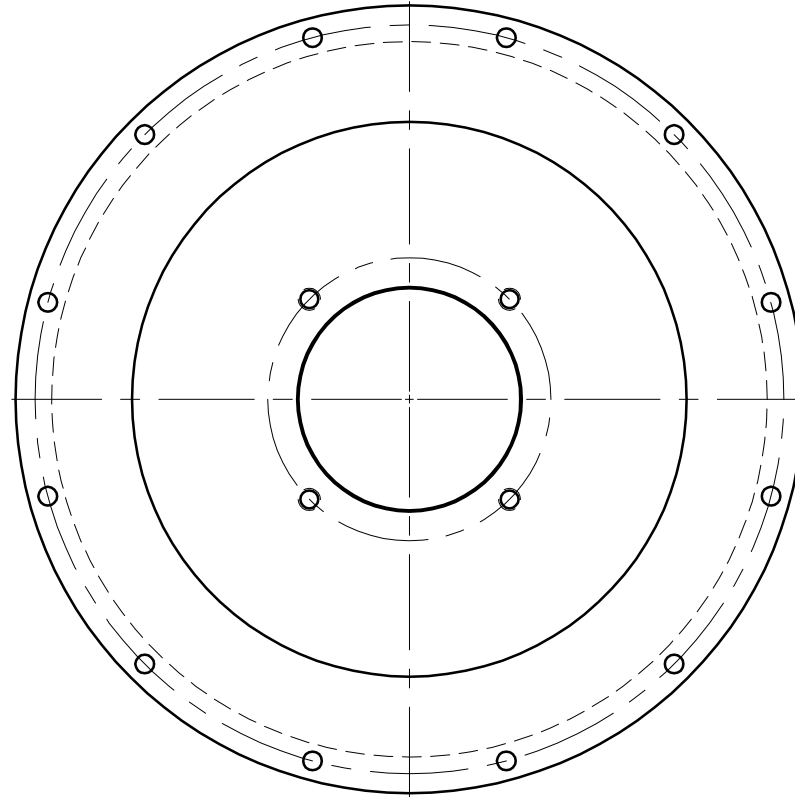
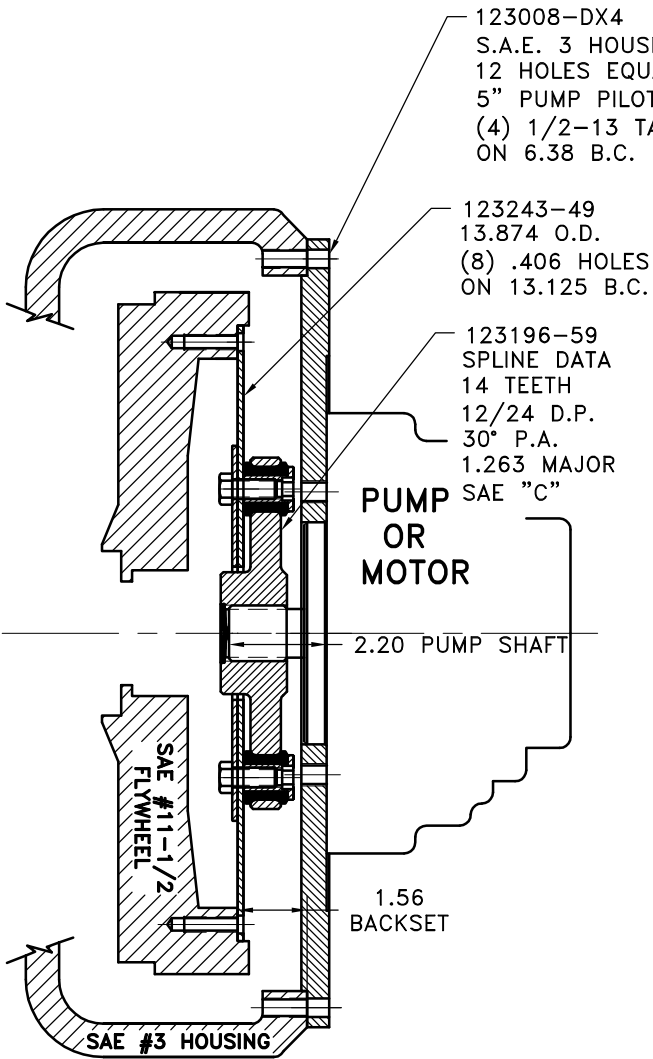

COUPLING ASS'Y #126933

UP TO 350 HP

REV	PART NUMBER	DESCRIPTION	QTY.
10	123008-DX4	PUMP MOUNT PLATE [5]	1
9	801912	GREASE	1
8	HP-1312-S-62	HUBBARD PLUG	1
7	HX200	7/16-20 x 1" HHB	12
5	123727	THREADED BUSHING	12
4	H62500	NEOPRENE INSERT	12
3	123196-59	COUPLING HUB [14 12/24\6.500]	1
2	124961-02	BACKING PLATE	1
1	123243-49	FLYWHEEL PLATE [11.5\6.500]	1

SYMBOLS	DET.	PART NUMBER	DESCRIPTION	QTY.
<ul style="list-style-type: none"> <li>▭ FLATNESS</li> <li>— STRAIGHTNESS</li> <li>∠ ANGULARITY</li> <li>⊥ SQUARENESS</li> <li>∥ PARALLELISM</li> <li>⊕ CONCENTRICITY</li> <li>⊙ TRUE POSITION</li> <li>⊘ ROUNDNESS</li> <li>⊙ CIRCULAR RUN OUT</li> <li>⊖ TOTAL RUN OUT</li> <li>⊘ CYLINDRICITY</li> <li>✓ FINISH</li> </ul>	DO NOT SCALE DRAWING TOLERANCES UNLESS OTHERWISE SPECIFIED 125 MAXIMUM ANGLE ±1/2° FRACTION ±1/32 DECIMAL .00 ±.01 .000 ±.005 .0000 ±.0005			
- UNLESS OTHERWISE SPECIFIED - REMOVE FIRST THREAD ON ALL TAPPED HOLES BREAK ALL SHARP CORNERS .010 TO .020 STAMP OR MARK DRAWING NO.			TITLE <b>FLYWHEEL COUPLING ASSY WITH PUMP MOUNT PLATE</b> MATERIAL	DRAWN BY SIETING CHECKED BY RJH
		DATE 09-10-03 SCALE	DRAWING NO. <b>127309</b> SHEET OF REV.	

THIS DRAWING IS THE PROPERTY OF HAYES MFG. INC. AND IS LOANED SUBJECT TO THE CONDITION THAT IT SHALL NOT BE REPRODUCED, COPIED, LOANED OR OTHERWISE DISPOSED OF, DIRECTLY OR INDIRECTLY. IT SHALL BE USED AS A MEANS OF REFERENCE TO WORK FURNISHED BY THIS COMPANY ONLY AND IS NOT TO BE SUBMITTED TO OUTSIDE PARTIES FOR EXAMINATION WITHOUT OUR CONSENT.