

REV	DATE	CHANGE DESCRIPTION	MOD. BY	CK1	CK2

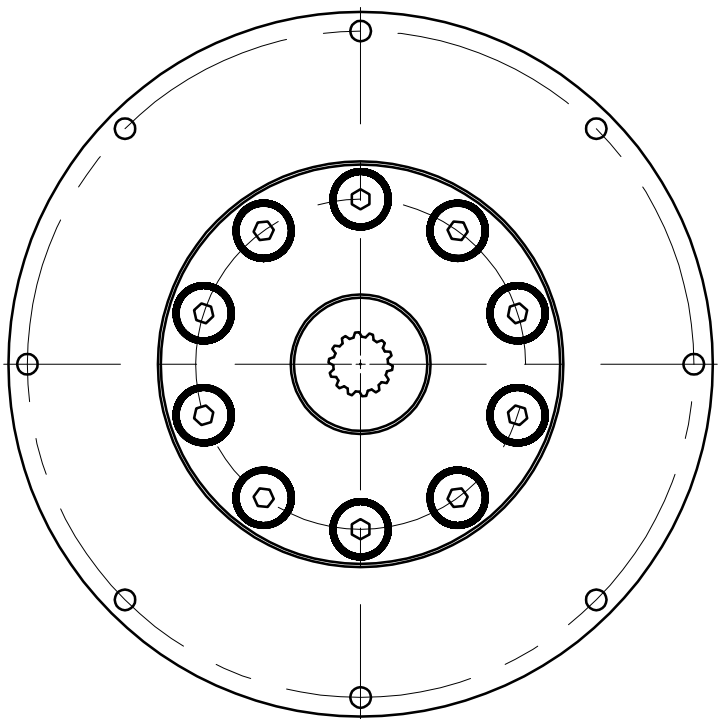
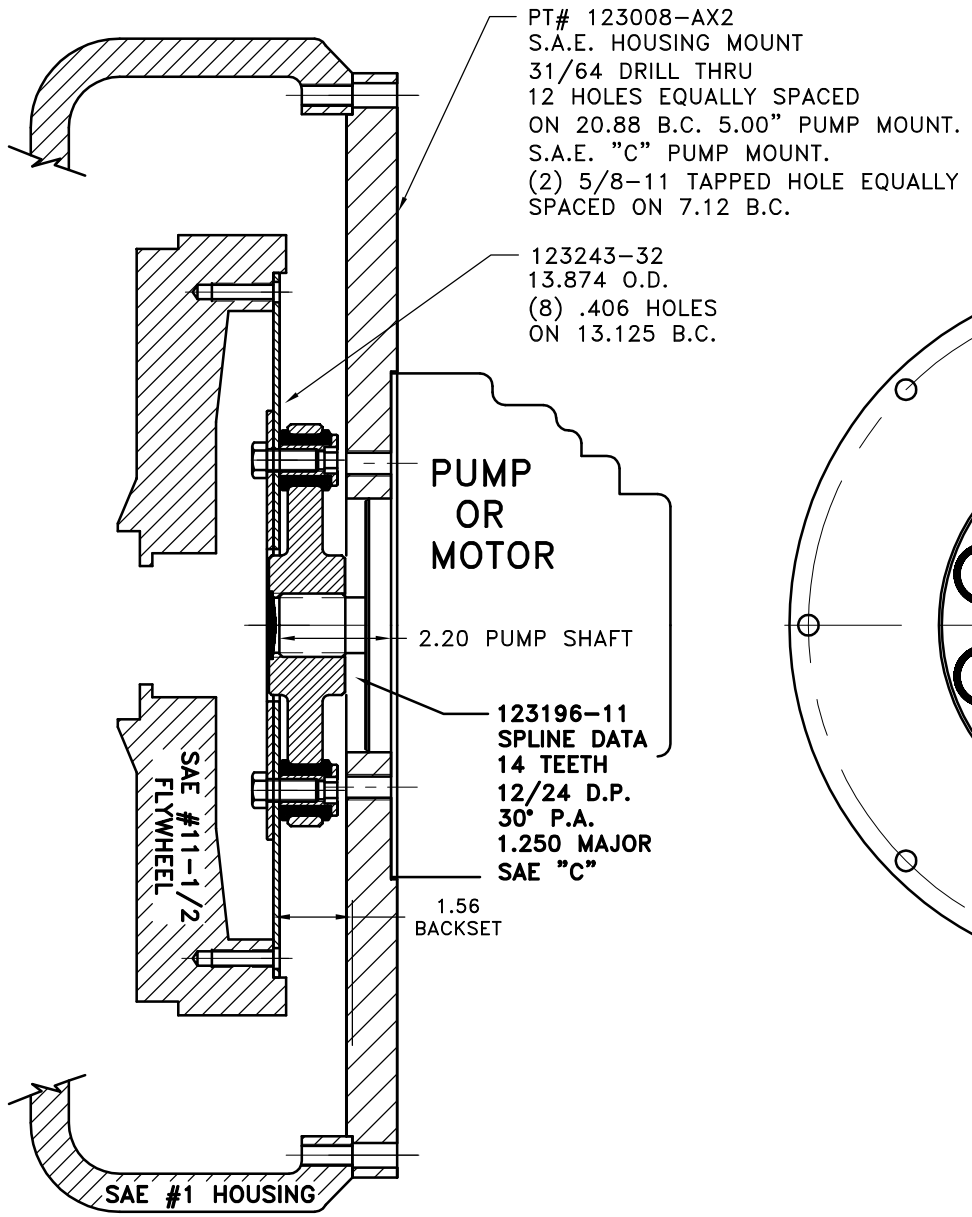

COUPLING ASS'Y
#124238

UP TO 250 HP

REV	PART NUMBER	DESCRIPTION	QTY.
9	123008-AX2	PUMP MOUNT PLATE	1
8	HP-1625-S-62	HUBBARD PLUG	1
7	801912	GREASE	1
6	HX200	7/16-20x1 HHB	10
5	123727	THREADED BUSHING	10
4	H62500	NEOPRENE INSERT	10
3	123196-11	COUPLING HUB	1
2	124961-01	BACKING PLATE	1
1	123243-32	FLYWHEEL PLATE	1

SYMBOLS	DET.	PART NUMBER	DESCRIPTION	QTY.
▨ FLATNESS — STRAIGHTNESS ∟ ANGULARITY ⊥ SQUARENESS ∥ PARALLELISM ⊙ CONCENTRICITY ⊕ TRUE POSITION ○ ROUNDNESS ⊙ CIRCULAR RUN OUT ⊙ TOTAL RUN OUT ⊙ CYLINDRICITY ✓ FINISH	DO NOT SCALE DRAWING TOLERANCES UNLESS OTHERWISE SPECIFIED ANGLE ±1/2° FRACTION ±1/32 DECIMAL .00 ±.01 .000 ±.005 .0000 ±.0005		 HAYES TM MANUFACTURING INC.	
- UNLESS OTHERWISE SPECIFIED - REMOVE FIRST THREAD ON ALL TAPPED HOLES BREAK ALL SHARP CORNERS .010 TO .020 STAMP OR MARK DRAWING NO.			TITLE FLYWHEEL COUPLING ASS'Y WITH PUMP MOUNT PLATE MATERIAL	DRAWN BY LAWSON
			DATE 10-9-03	DRAWING NO. 127337
			CHECKED BY SCALE	SHEET OF REV.

THIS DRAWING IS THE PROPERTY OF HAYES MFG. INC. AND IS LOANED SUBJECT TO THE CONDITION THAT IT SHALL NOT BE REPRODUCED, COPIED, LOANED OR OTHERWISE DISPOSED OF, DIRECTLY OR INDIRECTLY. IT SHALL BE USED AS A MEANS OF REFERENCE TO WORK FURNISHED BY THIS COMPANY ONLY AND IS NOT TO BE SUBMITTED TO OUTSIDE PARTIES FOR EXAMINATION WITHOUT OUR CONSENT.