

REV	DATE	CHANGE DESCRIPTION	MOD. BY	CK1	CK2

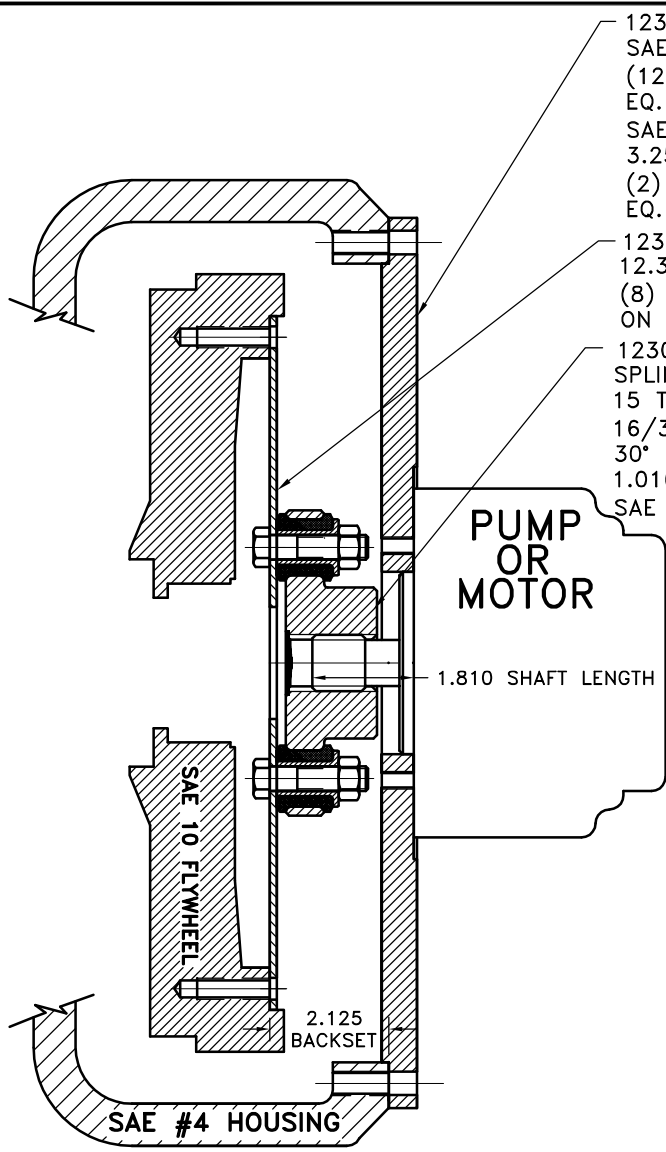

123008-EN2
SAE #4 HOUSING MOUNT
(12) 27/64 HOLES THRU
EQ. SPACED ON 15.00 B.C.
SAE "A" PUMP MOUNT
3.25 PUMP PILOT
(2) 3/8-16 TAPPED HOLES
EQ. SPACED ON 4.18 B.C.

123243-18
12.374 O.D.
(8) .406 HOLES
ON 11.625 B.C.

123044-10
SPLINE DATA
15 TEETH
16/32 D.P.
30° P.A.
1.016 MAJOR
SAE "B-B"

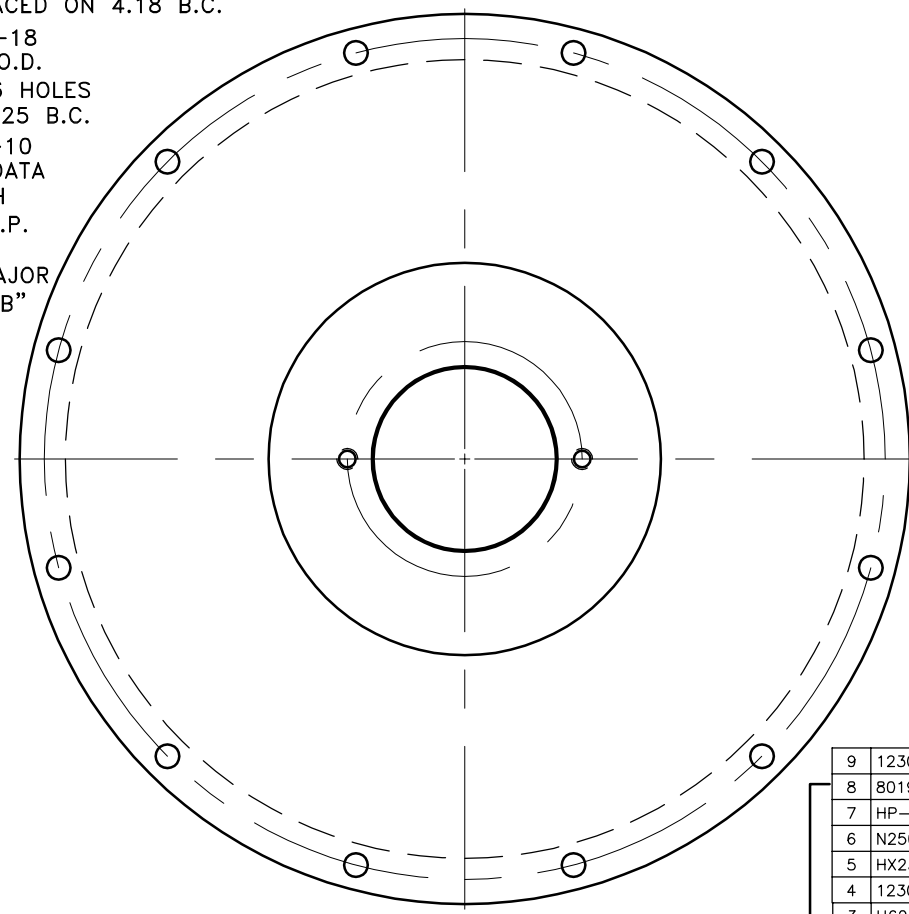

UP TO 110 H.P.

COUPLING ASS'Y
#124746

9	123008-EN2	PUMP MOUNT PLATE [4]	1
8	801912	GREASE	1
7	HP-1125-S-32	HUBBARD PLUG	1
6	N250	7/16-20 NUT	6
5	HX230	7/16-20x1-3/4 HHB	6
4	123000-00	STEEL BUSHING	6
3	H62500	NEOPRENE INSERT	6
2	123044-10	COUP. HUB [15 16/32\4.125]	1
1	123243-18	FLYWHEEL PLATE [10\4.125]	1

SYMBOLS	DET.	PART NUMBER	DESCRIPTION	QTY.
▨ FLATNESS — STRAIGHTNESS ∠ ANGULARITY ⊥ PERPENDICULARITY ∥ PARALLELISM ⊙ CONCENTRICITY ⊕ TRUE POSITION ○ ROUNDNESS Ⓞ CIRCULAR RUN OUT Ⓣ TOTAL RUN OUT Ⓜ CYLINDRICITY √ FINISH	DO NOT SCALE DRAWING TOLERANCES UNLESS OTHERWISE SPECIFIED 125 MAXIMUM ANGLE ±1/2° FRACTION ±1/32 DECIMAL .00 ±.01 .000 ±.005 .0000 ±.0005		HAYES MANUFACTURING INC. ® TITLE FLYWHEEL COUPLING ASSY WITH PUMP MOUNT PLATE MATERIAL	
- UNLESS OTHERWISE SPECIFIED - REMOVE FIRST THREAD ON ALL TAPPED HOLES BREAK ALL SHARP CORNERS .010 TO .020 STAMP OR MARK DRAWING NO.	DRAWN BY SIETING	DATE 01-12-04	DRAWING NO. 127413	SHEET OF REV.

THIS DRAWING IS THE PROPERTY OF HAYES MFG. INC. AND IS LOANED SUBJECT TO THE CONDITION THAT IT SHALL NOT BE REPRODUCED, COPIED, LOANED OR OTHERWISE DISPOSED OF, DIRECTLY OR INDIRECTLY. IT SHALL BE USED AS A MEANS OF REFERENCE TO WORK FURNISHED BY THIS COMPANY ONLY AND IS NOT TO BE SUBMITTED TO OUTSIDE PARTIES FOR EXAMINATION WITHOUT OUR CONSENT.