

REV	DATE	CHANGE DESCRIPTION	MOD. BY	CK1	CK2

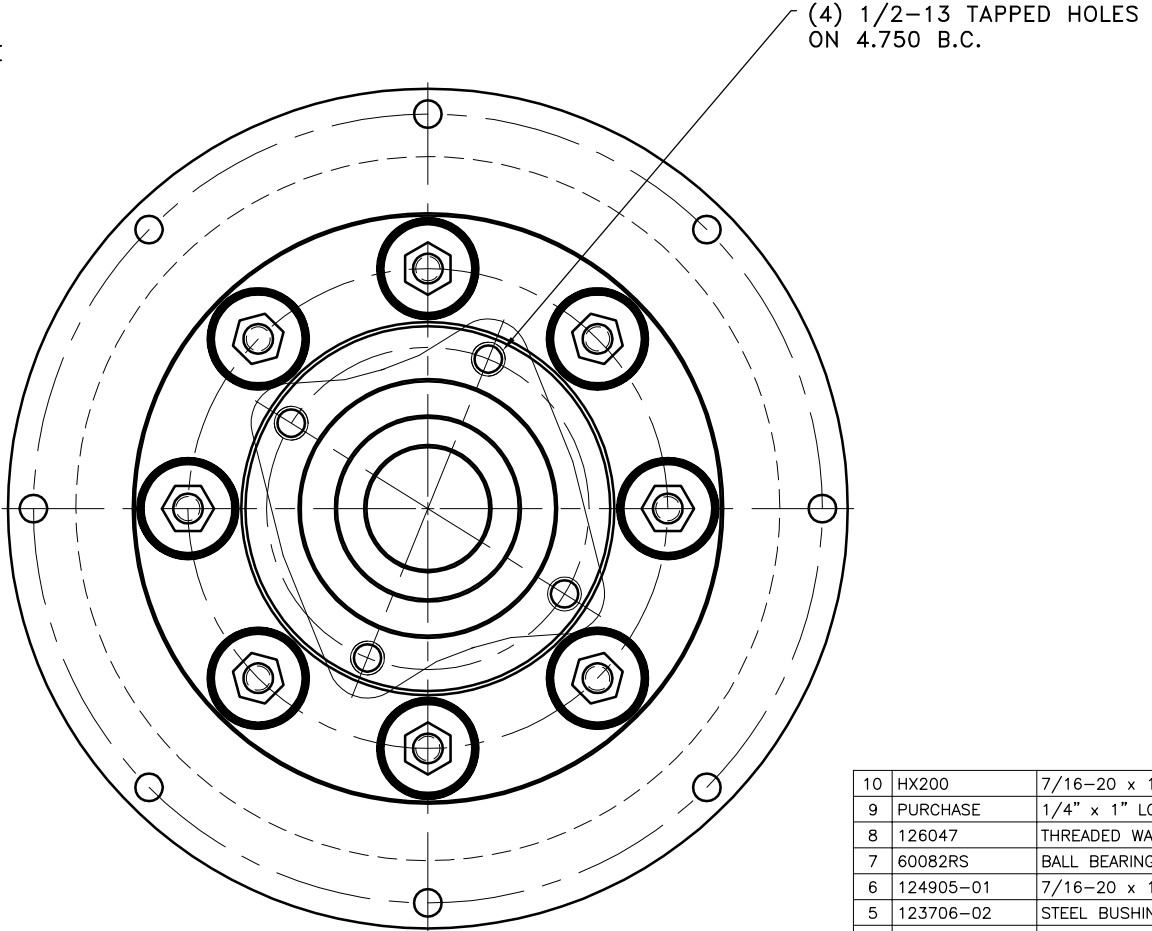
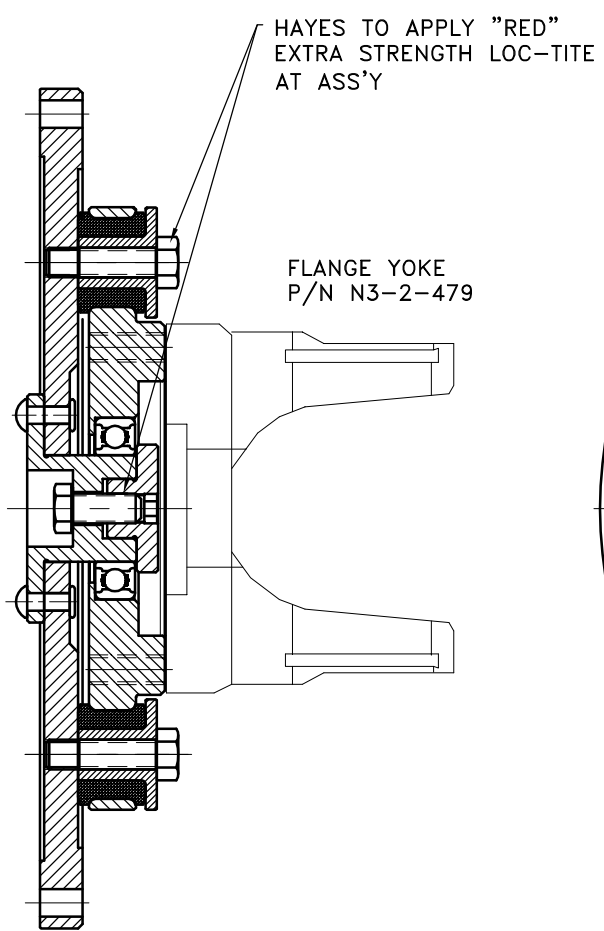

QTY.	DESCRIPTION	PART NUMBER	DET.
1	FLYWHEEL PLATE	125879-04	1
1	COUPLING ADAPTER	126578	2
1	PILOT	126579	3
8	NEOPRENE INSERT	H92500	4
8	STEEL BUSHING	123706-02	5
1	7/16-20 x 1.590" HHB	124905-01	6
1	BALL BEARING	60082RS	7
1	THREADED WASHER	126047	8
6	1/4" x 1" LG. FL. HD. RIVET	PURCHASE	9
1	7/16-20 x 1" HHB	HX200	10

FOR SPICER 1480 U-JOINT ADAPTER & SAE 10

SEE SIM. ASS'Y 126563

THIS DRAWING IS THE PROPERTY OF HAYES MFG. INC. AND IS LOANED SUBJECT TO THE CONDITION THAT IT SHALL NOT BE REPRODUCED, COPIED, LOANED OR OTHERWISE DISPOSED OF, DIRECTLY OR INDIRECTLY. IT SHALL BE USED AS A MEANS OF REFERENCE TO WORK FURNISHED BY THIS COMPANY ONLY AND IS NOT TO BE SUBMITTED TO OUTSIDE PARTIES FOR EXAMINATION WITHOUT OUR CONSENT.

SYMBOLS		DET.	PART NUMBER	DESCRIPTION	QTY.
∕	FLATNESS	DO NOT SCALE			
—	STRAIGHTNESS	DRAWING			
∠	ANGULARITY	TOLERANCES UNLESS OTHERWISE SPECIFIED			
⊥	SQUARENESS	125/ MAXIMUM			
∥	PARALLELISM	ANGLE ±1/2°			
⊙	CONCENTRICITY	FRACTION ±1/32			
⊕	TRUE POSITION	DECIMAL			
⊖	ROUNDNESS	.00 ±.01			
⊘	CIRCULAR RUN OUT	.000 ±.005			
⊙	TOTAL RUN OUT	.0000 ±.0005			
⊘	CYLINDRICITY				
√	FINISH				
- UNLESS OTHERWISE SPECIFIED -		REMOVE FIRST THREAD ON ALL TAPPED HOLES			
BREAK ALL SHARP CORNERS .010 TO .020		STAMP OR MARK DRAWING NO.			
DRAWN BY SIETING		DATE 04-08-04		DRAWING NO. 127519	
CHECKED BY RJH		SCALE		SHEET OF REV.	



U-JOINT ADAPTER ASS'Y