

REV	DATE	CHANGE DESCRIPTION	MOD. BY	CK1	CK2

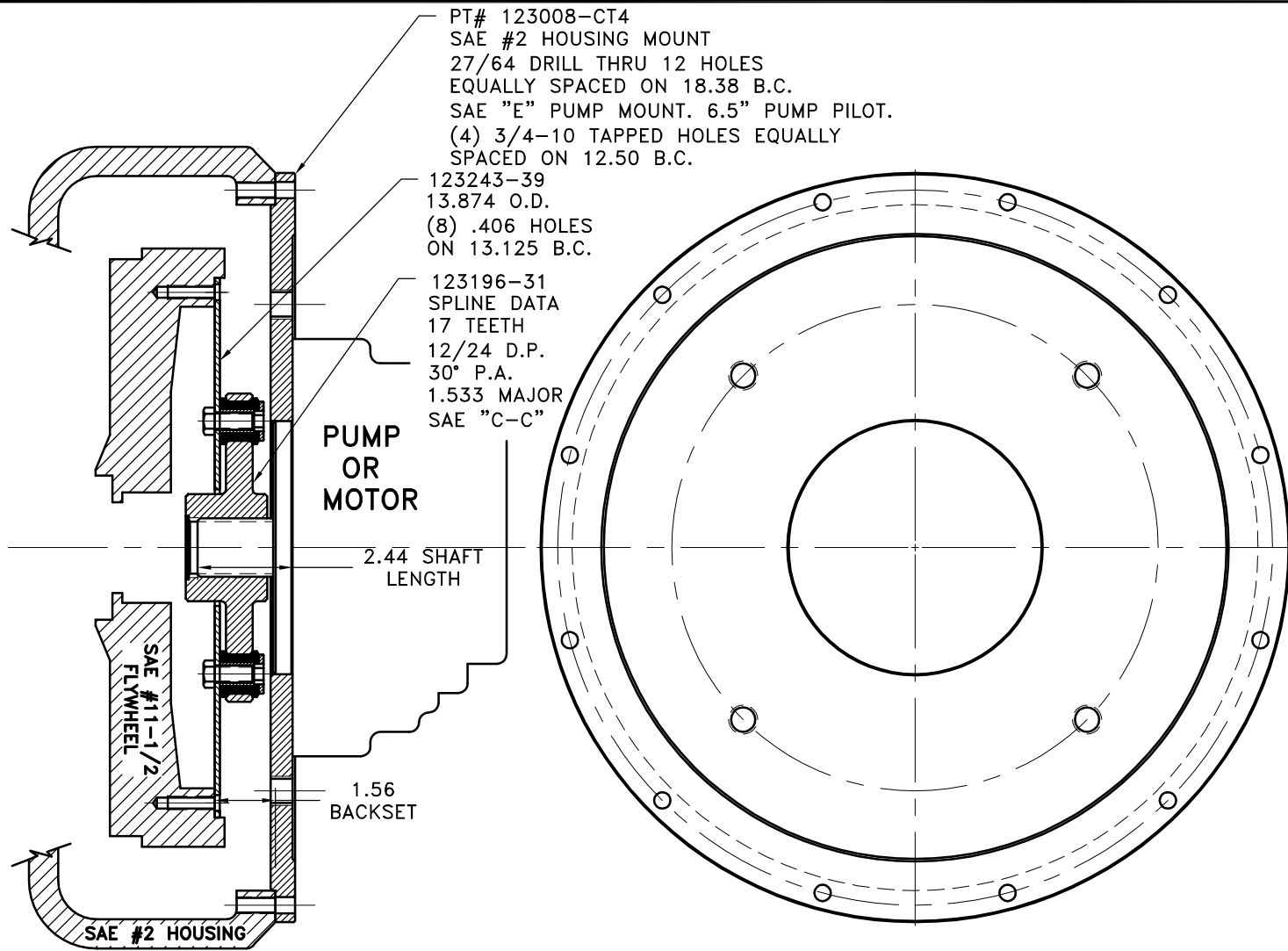

PT# 123008-CT4  
 SAE #2 HOUSING MOUNT  
 27/64 DRILL THRU 12 HOLES  
 EQUALLY SPACED ON 18.38 B.C.  
 SAE "E" PUMP MOUNT. 6.5" PUMP PILOT.  
 (4) 3/4-10 TAPPED HOLES EQUALLY  
 SPACED ON 12.50 B.C.

123243-39  
 13.874 O.D.  
 (8) .406 HOLES  
 ON 13.125 B.C.

123196-31  
 SPLINE DATA  
 17 TEETH  
 12/24 D.P.  
 30° P.A.  
 1.533 MAJOR  
 SAE "C-C"

PUMP  
 OR  
 MOTOR

2.44 SHAFT  
 LENGTH

1.56  
 BACKSET

SAE #11-1/2  
 FLYWHEEL

SAE #2 HOUSING

UP TO 350 HP

COUPLING ASS'Y #124622

QTY.	DESCRIPTION	PART NUMBER	DET.
1	FLYWHEEL PLATE [11.5\6.500]	123243-49	1
1	COUP HUB [17T12/24\6.500]	123196-31	2
12	NEOPRENE INSERT	H62500	3
12	THREADED BUSHING	123727	4
1	HUBBARD PLUG	HP-1625-S-62	6
1	GREASE	801912	7
1	PUMP MOUNT PLATE [2\E4BOLT]	123008-CT4	8

SYMBOLS		DET.	PART NUMBER	DESCRIPTION	QTY.
▭	FLATNESS	DO NOT SCALE			
—	STRAIGHTNESS	DRAWING			
∠	ANGULARITY	TOLERANCES UNLESS			
⊥	SQUARENESS	OTHERWISE SPECIFIED			
∥	PARALLELISM	125	MAXIMUM		
⊙	CONCENTRICITY	ANGLE ±1/2°			
⊕	TRUE POSITION	FRACTION ±1/32			
⊖	ROUNDNESS	DECIMAL			
⊘	CIRCULAR RUN OUT	.00 ±.01			
⊙	TOTAL RUN OUT	.000 ±.005			
⊘	CYLINDRICITY	.0000 ±.0005			
√	FINISH				



TITLE  
 FLYWHEEL COUPLING ASSY WITH PUMP MOUNT PLATE

MATERIAL

- UNLESS OTHERWISE SPECIFIED - REMOVE FIRST THREAD ON ALL TAPPED HOLES BREAK ALL SHARP CORNERS .010 TO .020 STAMP OR MARK DRAWING NO.	DRAWN BY SIETING	DATE 11-01-05	DRAWING NO. 128050
	CHECKED BY RJH	SCALE	SHEET OF REV.

THIS DRAWING IS THE PROPERTY OF HAYES MFG. INC. AND IS LOANED SUBJECT TO THE CONDITION THAT IT SHALL NOT BE REPRODUCED, COPIED, LOANED OR OTHERWISE DISPOSED OF, DIRECTLY OR INDIRECTLY. IT SHALL BE USED AS A MEANS OF REFERENCE TO WORK FURNISHED BY THIS COMPANY ONLY AND IS NOT TO BE SUBMITTED TO OUTSIDE PARTIES FOR EXAMINATION WITHOUT OUR CONSENT.