

CUSTOMER DRAWING

REVISIONS						
ZONE	REV.	DESCRIPTION	DATE	APR 1	APR 2	DCR #
B2, 3-B2, 5-A2	A	RELEASED IN SW; WAS 213WDN NOW 213Z	19-SEP-24			4442

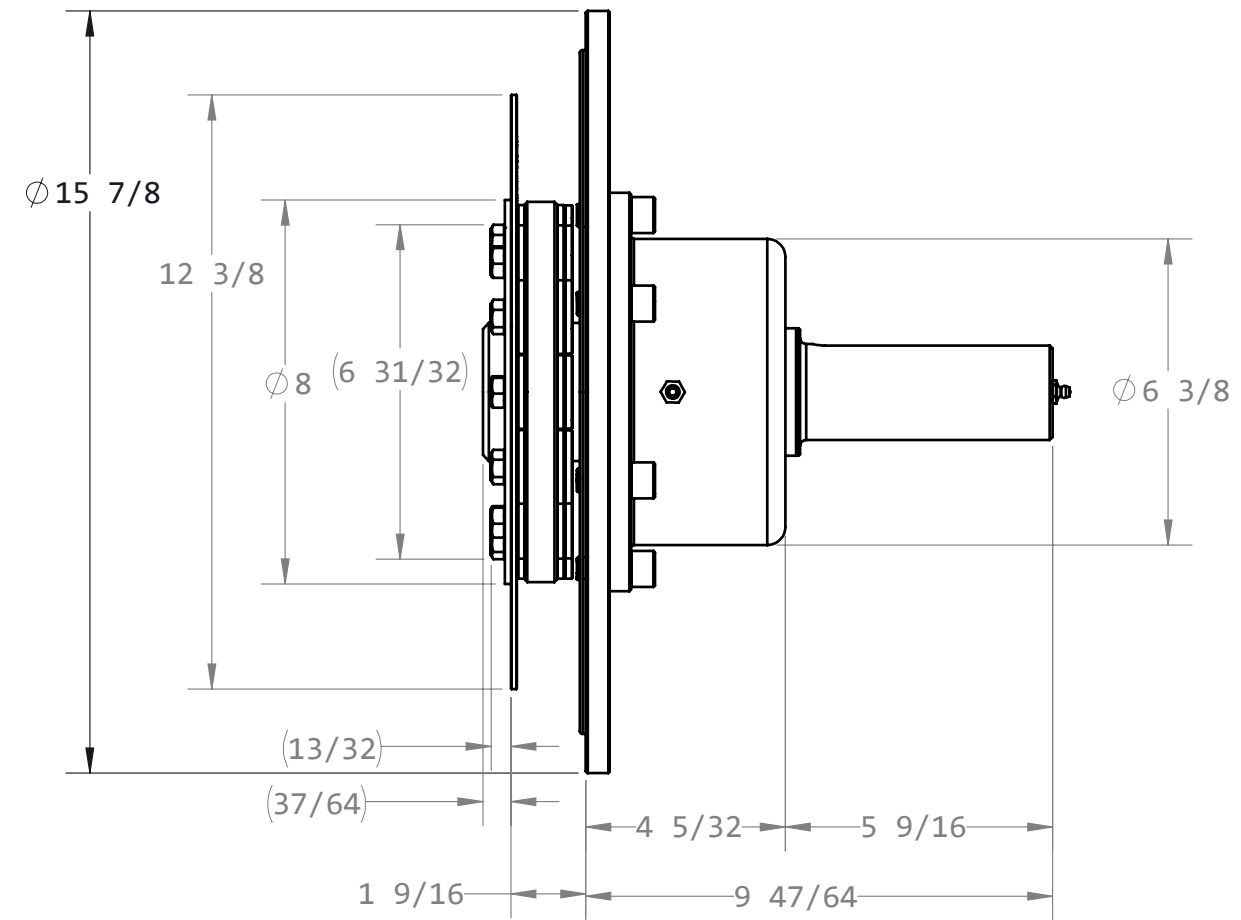
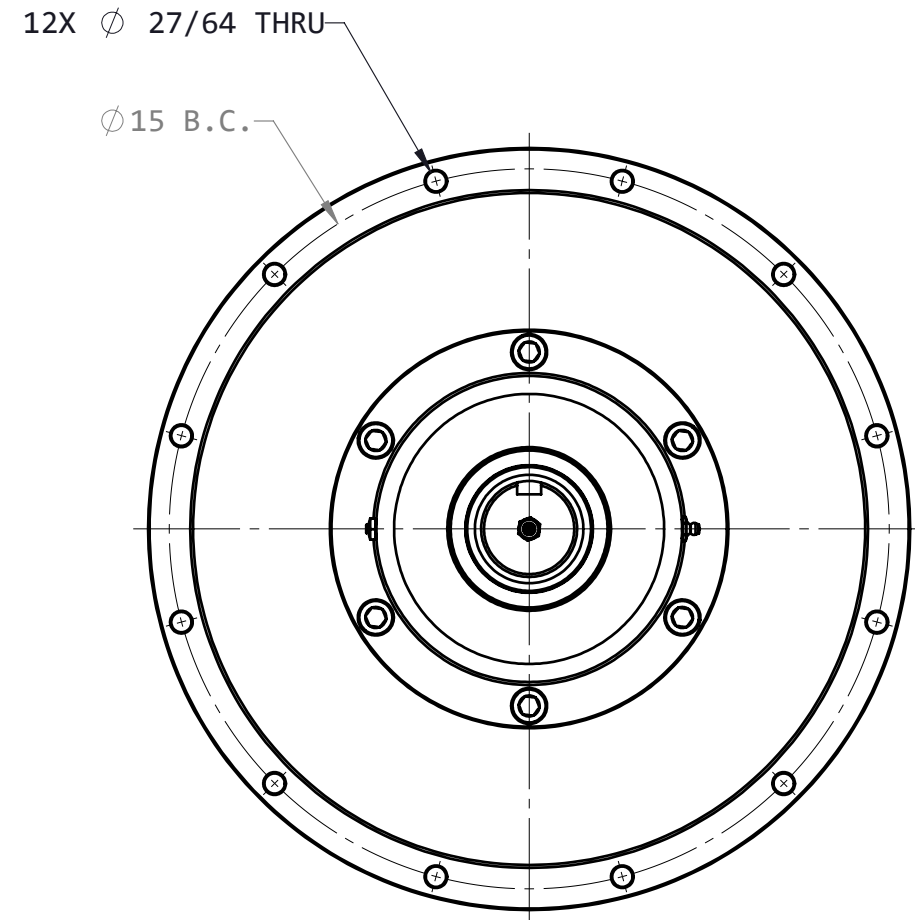
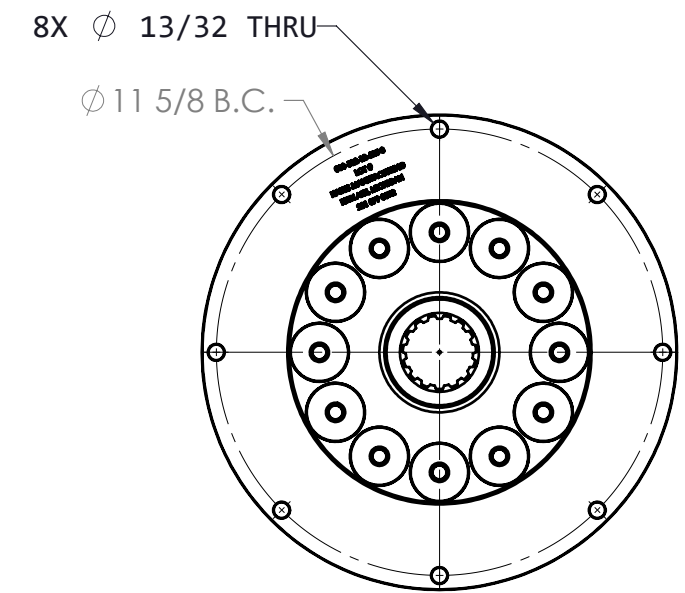
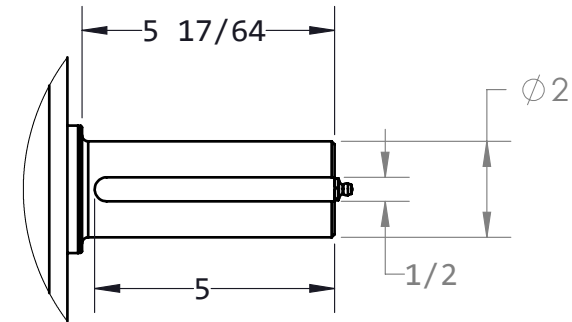

FLYWHEEL COUPLING FRONT VIEW

COUPLING IS NOT SERVICEABLE

ITEM NO.	PART NUMBER	DESCRIPTION	QTY.
1	126198	FLYWHEEL COUPLING ASSEMBLY	1
2	132718	PUMP MOUNT PLATE	1
3	134802	BEARING SUPPORT SUB ASSY	1
4	1/2-13X1-1/8 SHCS	1/2-13 X 1-1/8 SHCS	6

PUMP DRIVE SPECS	
FLYWHEEL	SAE 10
HOUSING	SAE 4
PUMP SHAFT	2" DIA. X 1/2" KEY
HP RATING (@1800 RPM)	250

UNLESS OTHERWISE SPECIFIED:		SYMBOLS	
DIMENSIONS ARE IN INCHES		FLATNESS	CONCENTRICITY
TOLERANCES:		ROUNDNESS	TRUE POSITION
FRACTIONAL: ±1/32	ANGULAR: MACH: ±1/2"	PARALLELISM	PERPENDICULARITY
TWO DECIMAL: ±.01	THREE DECIMAL: ±.005	"R" RADIUS	TOTAL RUN OUT
FOUR DECIMAL: ±.0005		COUNTERBORE	COUNTERSINK
		HOLE DEPTH	SYMMETRIC

PROPRIETARY AND CONFIDENTIAL  
THE INFORMATION CONTAINED IN THIS DRAWING IS THE SOLE PROPERTY OF HAYES MANUFACTURING. ANY REPRODUCTION IN PART OR AS A WHOLE WITHOUT THE WRITTEN PERMISSION OF HAYES MANUFACTURING IS PROHIBITED.

NAME	DATE
DRAWN: VHA	6/24/2021
PCM APPR.	
ENG APPR.: ZS	9/18/2024
MFG APPR.	
QA APPR.	
MATERIAL	

**HAYES**

TITLE: BEARING SUPPORTED STUB SHAFT KIT

DWG. NO. 132717

REV A

DO NOT SCALE SHEET 1 OF 5