

REV	DATE	CHANGE DESCRIPTION	MOD. BY	CK1	CK2
C	05/20/2010	CHANGED TO 1011 WOODRUFF KEY	ZS	RJH	

NOTES:

- WARNING!!!** INJURY OR DEATH FROM A ROTATING STUB SHAFT CAN OCCUR IF A CONDITION EXISTS WHICH WOULD CAUSE THE SHAFT TO BREAK OR COME APART FROM ANY PART OF THE ASSEMBLY. DEPENDING UPON THE APPLICATION (FOR EXAMPLE, FAN, PULLEY, SHEAVE, ETC.), THE AREA AROUND THE STUB SHAFT MUST BE SUFFICIENTLY GUARDED SO THAT IN THE EVENT OF FAILURE, THE GUARD WILL CONTAIN ANY AIRBORNE PARTS.

ASSEMBLY NOTE:

MUST USE DOUBLE SEALED BEARINGS.

HUB/SHAFT ORIENTATION

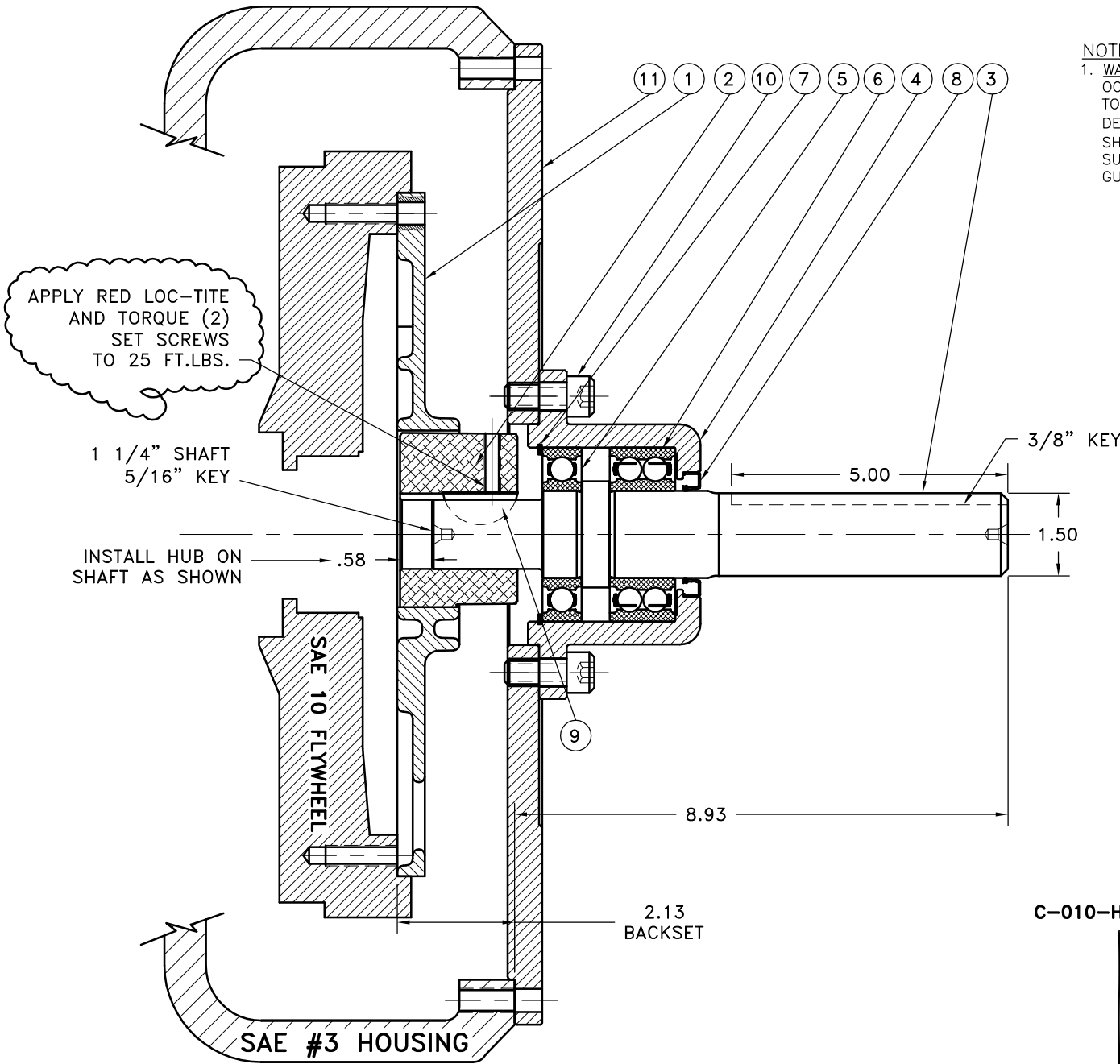
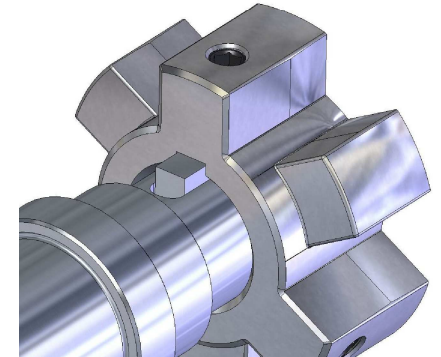

150-L
C-010-HC4-43

NO.	PART NUMBER	DESCRIPTION	QTY.
11	123008-DO4	PUMP MOUNT PLATE [3\B4BOLT]	1
10	740000	1/2-13 SHCS	4
9	23-1011	1 3/8 x 5/16 WOODRUFF KEY	1
8	CRW1R15830	SEAL	1
7	RR-314	SPIROLOX RETAINING RING	1
6	5208-2RS	DOUBLE BEARING	1
5	6208-2RS	BEARING	1
4	128498	BEARING HOUSING	1
3	150000-02	STUB SHAFT	1
2	HC4-43	HEX~FLX HUB	1
1	C-010	HEX~FLX DRIVE PLATE	1

SYMBOLS		DET.	PART NUMBER	DESCRIPTION	QTY.
▨ FLATNESS — STRAIGHTNESS ∠ ANGULARITY ⊥ PERPENDICULARITY ∥ PARALLELISM ⊙ CONCENTRICITY ⊕ TRUE POSITION ○ ROUNDNESS Ⓞ CIRCULAR RUN OUT Ⓣ TOTAL RUN OUT Ⓜ CYLINDRICITY √ FINISH		DO NOT SCALE DRAWING			
		TOLERANCES UNLESS OTHERWISE SPECIFIED			
		125 MAXIMUM			
		ANGLE ±1/2°			
		FRACTION ±1/32			
		DECIMAL			
		.00 ±.01			
		.000 ±.005			
		.0000 ±.0005			
HAYES MANUFACTURING INC. ®		TITLE BEARING SUPPORTED STUB SHAFT ASS'Y		MATERIAL	
CLASS	MAKE: <input type="checkbox"/> BUY: <input type="checkbox"/>	DRAWN BY	DATE	DRAWING NO.	
DESCRIPTION		SIETING	09-14-05	150-010-03-L	
		CHECKED BY	SCALE	SHEET OF REV.	
		RJH			

THIS DRAWING IS THE PROPERTY OF HAYES MFG. INC. AND IS LOANED SUBJECT TO THE CONDITION THAT IT SHALL NOT BE REPRODUCED, COPIED, LOANED OR OTHERWISE DISPOSED OF, DIRECTLY OR INDIRECTLY. IT SHALL BE USED AS A MEANS OF REFERENCE TO WORK FURNISHED BY THIS COMPANY ONLY AND IS NOT TO BE SUBMITTED TO OUTSIDE PARTIES FOR EXAMINATION WITHOUT OUR CONSENT.