

| REV | DATE | CHANGE DESCRIPTION | MOD. BY | CK1 | CK2 |
|-----|------|--------------------|---------|-----|-----|
| | | | | | |

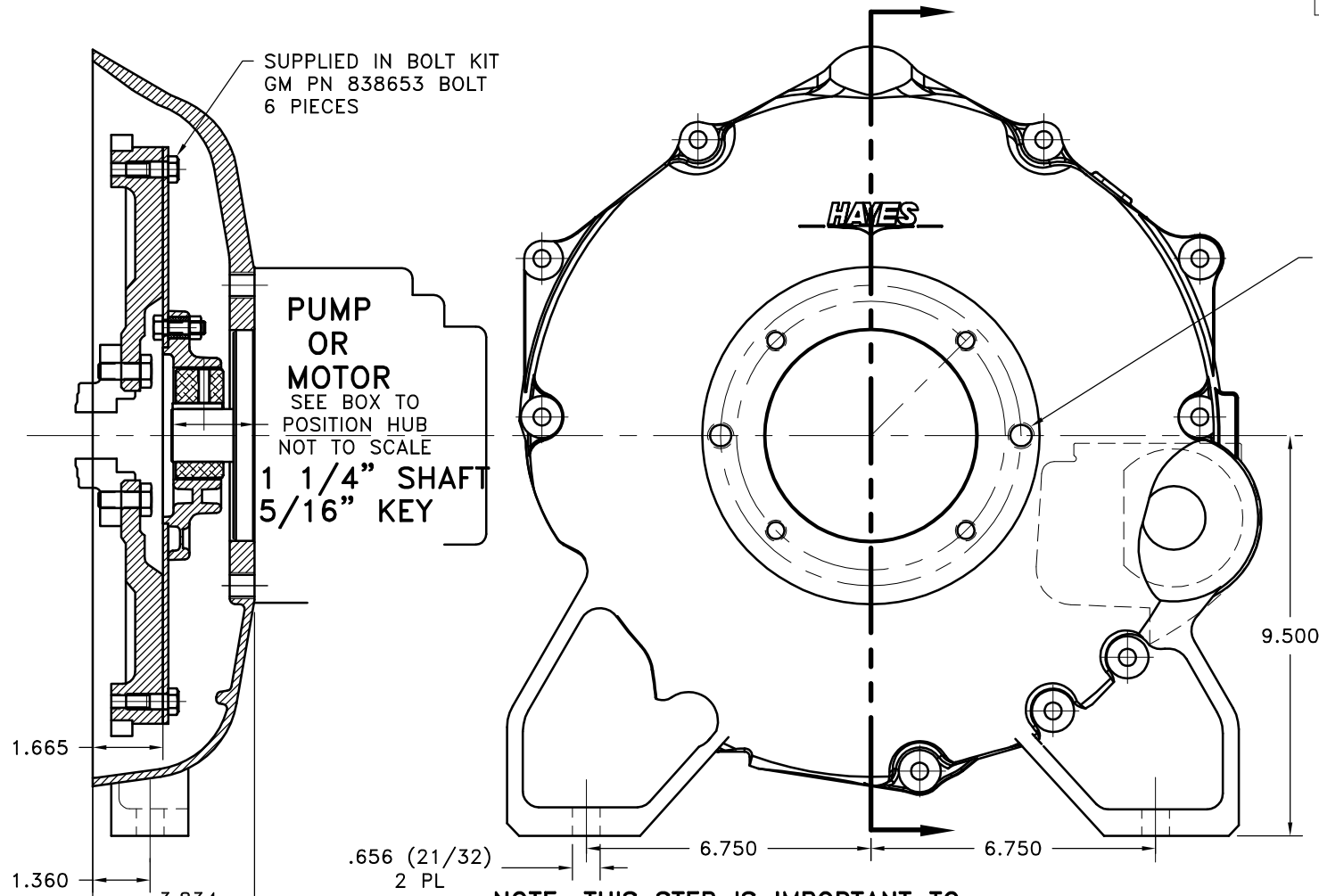

SUPPLIED IN BOLT KIT
GM PN 838653 BOLT
6 PIECES

PUMP OR MOTOR
SEE BOX TO POSITION HUB
NOT TO SCALE
1 1/4" SHAFT
5/16" KEY

SAE "C" PUMP MOUNT
5.00 PUMP PILOT
2-BOLT MOUNT
(2) 5/8-11 TAPPED HOLES
EQ. SPACED ON 7.13 B.C.
(4) 1/2-13 TAPPED HOLES
EQ. SPACED ON A 6.375.

GM 5.7 LITRE

NOTE: REMOVE HUB FROM ASS'Y, PRESET HUB ON SHAFT & REASSEMBLE USING NUT & BOLT GRADE LOC-TITE ON SET SCREWS. SHAFT SHOULD HAVE A MINIMUM OF 3/4" OF ENGAGEMENT IF NOT CONTACT FACTORY FOR RECOMMENDATIONS. TO GET HUB PRESET USE THIS EQUATION:

EXAMPLE:
1.87 - SHAFT LENGTH = HUB PRESET

IF YOUR ANSWER IS (+) SHAFT IS INSIDE OF HUB, IF YOUR ANSWER IS (-) SHAFT STICKS OUT OF HUB. (SEE BOXES)

THIS DRAWING IS THE PROPERTY OF HAYES MFG. INC. AND IS LOANED SUBJECT TO THE CONDITION THAT IT SHALL NOT BE REPRODUCED, COPIED, LOANED OR OTHERWISE DISPOSED OF, DIRECTLY OR INDIRECTLY. IT SHALL BE USED AS A MEANS OF REFERENCE TO WORK FURNISHED BY THIS COMPANY ONLY AND IS NOT TO BE SUBMITTED TO OUTSIDE PARTIES FOR EXAMINATION WITHOUT OUR CONSENT.

NOTE: THIS STEP IS IMPORTANT TO ENSURE FULL SPLINE ENGAGEMENT.

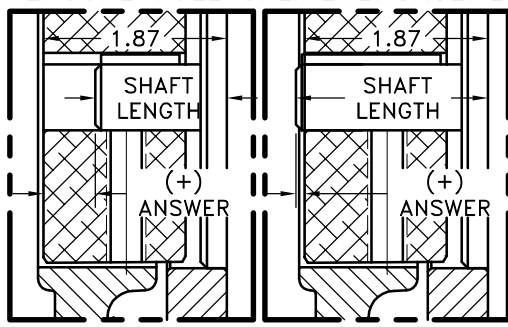

FLYWHEEL PLATE ASS'Y #128453

| | | | |
|---|-----------|----------------------|---|
| 8 | 890010 | 4.3 LITRE DUST COVER | 1 |
| 7 | 890013 | BOLT KIT | 1 |
| 6 | 890000-11 | HOUSING | 1 |
| 5 | HB1-43 | HEX~FLX HUB | 1 |
| 4 | PURCHASE | 5/16-18 NUT | 5 |
| 3 | PURCHASE | 5/16-18 x 1" HHB | 5 |
| 2 | B-SMN | HEX~FLX PLATE | 1 |
| 1 | 128452 | FLYWHEEL PLATE | 1 |

| SYMBOLS | DET. | PART NUMBER | DESCRIPTION | QTY. |
|---|--|---------------------|------------------|--|
| ▭ FLATNESS ▭ STRAIGHTNESS ▭ ANGULARITY ▭ PERPENDICULARITY ▭ PARALLELISM ▭ CONCENTRICITY ⊕ TRUE POSITION ○ ROUNDNESS ○ CIRCULAR RUN OUT ○ TOTAL RUN OUT R FINISH ▭ FINISH | DO NOT SCALE DRAWING TOLERANCES UNLESS OTHERWISE SPECIFIED 1/32" MAXIMUM ANGLE ±1/2° FRACTION ±1/32 DECIMAL .00 ±.01 .000 ±.005 .0000 ±.0005 | | | |
| HAYES <small>MANUFACTURING INC. ®</small> | | | | |
| TITLE GM HOUSING & FLYWHEEL COUPLING ASS'Y | | | | |
| MATERIAL | | | | |
| - UNLESS OTHERWISE SPECIFIED - REMOVE FIRST THREAD ON ALL TAPPED HOLES BREAK ALL SHARP CORNERS .010 TO .020 STAMP OR MARK DRAWING NO. | | DRAWN BY SIETING | DATE 11-21-06 | DRAWING NO. 029-S-HB1-43-C24 |
| | | CHECKED BY RJH | SCALE | SHEET OF REV. |