

REV	DATE	CHANGE DESCRIPTION	MOD.BY	CK1	CK2

DAIHATSU STARTER PLATE M10 BOLTS TORQUE 29-33 FT.LBS

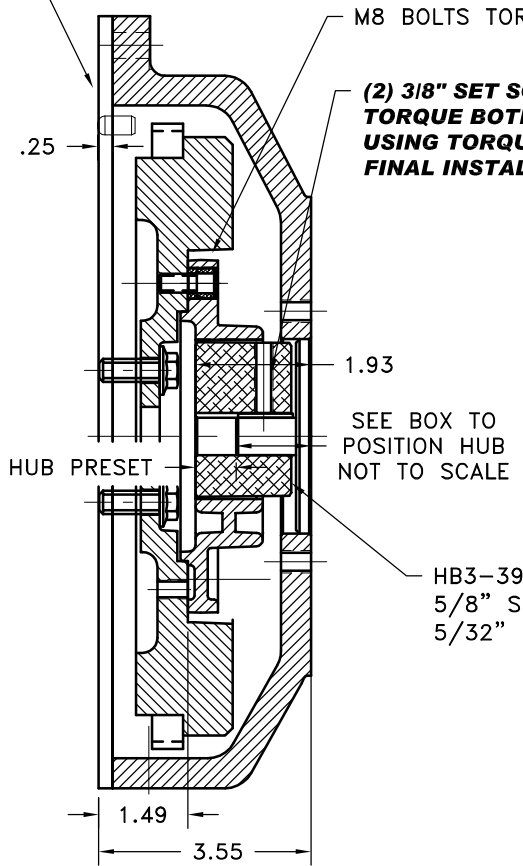

M8 BOLTS TORQUE TO 20-25 FT.LBS.

(2) 3/8" SET SCREWS
TORQUE BOTH TO 20 FT. LBS
USING TORQUE WRENCH AT
FINAL INSTALLATION

SEE BOX TO
POSITION HUB
NOT TO SCALE

HB3-39
5/8" SHAFT
5/32" KEY

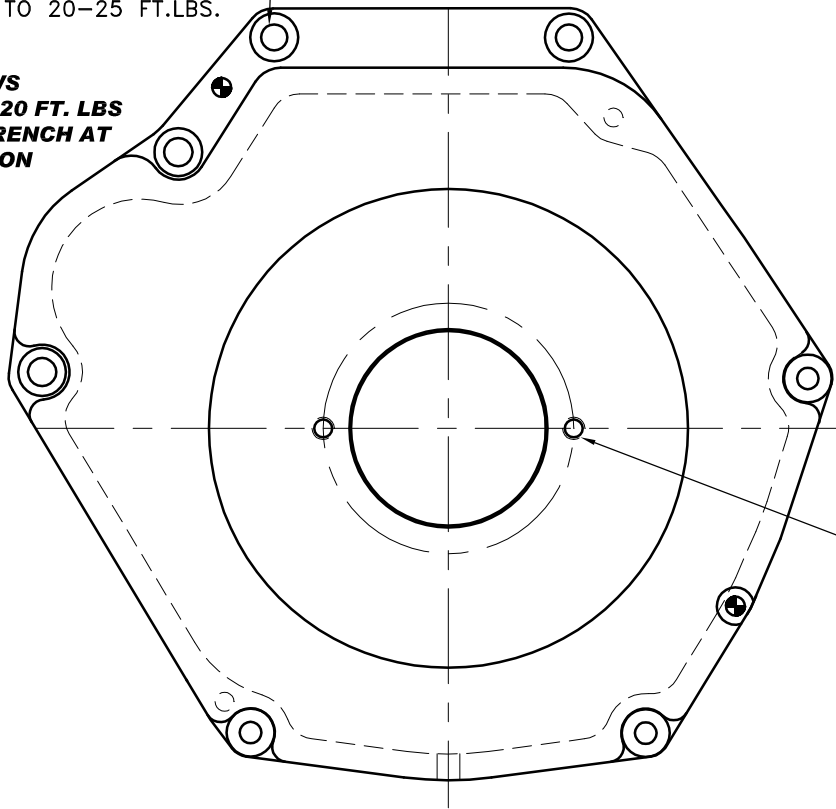

.312 DR. THRU
3/8-16 TAP THRU
(2) HOLES EQ SPACED
ON A 4.187 B.C.

NOTES:
1. HOUSING FOR DAIHATSU ENGINES DM700G & DM950G.

IMPORTANT INSTALLATION NOTE!!!!

IMPROPER INSTALLATION OF HUB COULD CAUSE PREMATURE WEAR AND OR FAILURE.

IF YOU HAVE QUESTIONS CONCERNING LOCATION OF METAL HUB ON PUMP SHAFT PLEASE CONTACT DISTRIBUTOR OR FACTORY FOR FURTHER INFORMATION.

BOTH HUB SET SCREWS MUST BE PROPERLY TORQUED TO 25 FT.LBS. USING TORQUE WRENCH. PLEASE CONTACT DISTRIBUTOR OR FACTORY FOR ANY FURTHER QUESTIONS.

NOTE: REMOVE HUB FROM ASS'Y, PRESET HUB ON SHAFT AS SHOWN. **TORQUE BOTH SET SCREWS TO 25 FT.LBS. USING TORQUE WRENCH.** SHAFT SHOULD HAVE A MINIMUM OF 3/4" OF ENGAGEMENT IF NOT CONTACT FACTORY FOR RECOMMENDATIONS (231) 879-3372 TO GET HUB PRESET USE THIS EQUATION:

PERFORM CALCULATION BELOW:
1.93 - SHAFT LENGTH = HUB PRESET

IF YOUR ANSWER IS (+) SHAFT IS INSIDE OF HUB, IF YOUR ANSWER IS (-) SHAFT STICKS OUT OF HUB. (SEE BOXES)

NOTE: THIS STEP IS IMPORTANT TO ENSURE FULL SHAFT ENGAGEMENT.

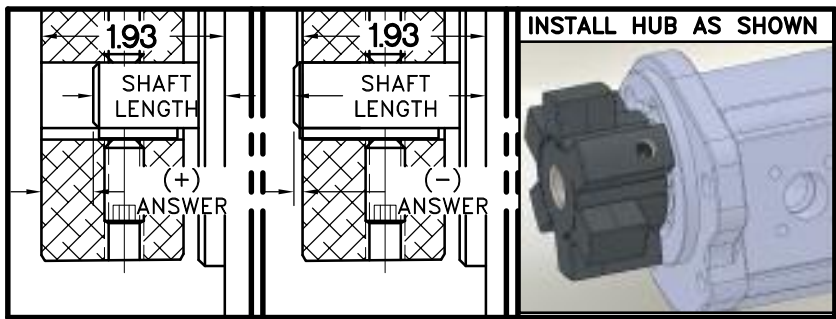

UP TO 50 HP

DET.	PART NUMBER	DESCRIPTION	QTY.
4	969001-04	HOUSING	1
3	969024	BOLT KIT	1
2	HB3-39	HEX~FLX HUB	1
1	B-SMN	HEX~FLX PLATE	1

SYMBOLS		DET.	PART NUMBER	DESCRIPTION	QTY.			
▭	FLATNESS	DO NOT SCALE DRAWING TOLERANCES UNLESS OTHERWISE SPECIFIED 1/32" MAXIMUM ANGLE ±1/2° FRACTION ±1/32 DECIMAL .00 ±.01 .000 ±.005 .0000 ±.0005 UNLESS OTHERWISE SPECIFIED - REMOVE FIRST THREAD ON ALL TAPPED HOLES BREAK ALL SHARP CORNERS .010 TO .020 STAMP OR MARK DRAWING NO.						
▭	STRAIGHTNESS							
▭	ANGULARITY							
⊥	PERPENDICULARITY							
∥	PARALLELISM							
◎	CONCENTRICITY							
⊕	TRUE POSITION							
⊙	ROUNDNESS							
⊘	CIRCULAR RUN OUT							
⊘	TOTAL RUN OUT							
⊘	CYLINDRICITY							
⊘	FINISH							
HAYES MANUFACTURING INC. ® TITLE DAIHATSU HEX~FLX HOUSING ASS'Y MATERIAL						DRAWN BY	DATE	DRAWING NO.
DRAWN BY SIETING CHECKED BY						DATE 10-06-08 SCALE	DRAWING NO. 030-0-HB3-39-A2 SHEET OF REV.	