

REV	DATE	CHANGE DESCRIPTION	MOD.BY	CK1	CK2

SPECIAL FOR D902

NOTES:

- HOUSING FOR KUBOTA ENGINES D902

SAE "A" 2-BOLT MOUNT
 3.25 DIA PUMP PILOT
 (2) 3/8-16 TAPPED HOLES
 EQ. SPACED ON 4.18 B.C.

IMPORTANT INSTALLATION NOTE!!!!

IMPROPER INSTALLATION OF HUB COULD CAUSE PREMATURE WEAR AND OR FAILURE.

IF YOU HAVE QUESTIONS CONCERNING LOCATION OF METAL HUB ON PUMP SHAFT PLEASE CONTACT DISTRIBUTOR OR FACTORY FOR FURTHER INFORMATION.

BOTH HUB SET SCREWS MUST BE PROPERLY TORQUED TO 25 FT.LBS. USING TORQUE WRENCH . PLEASE CONTACT DISTRIBUTOR OR FACTORY FOR ANY FURTHER QUESTIONS.

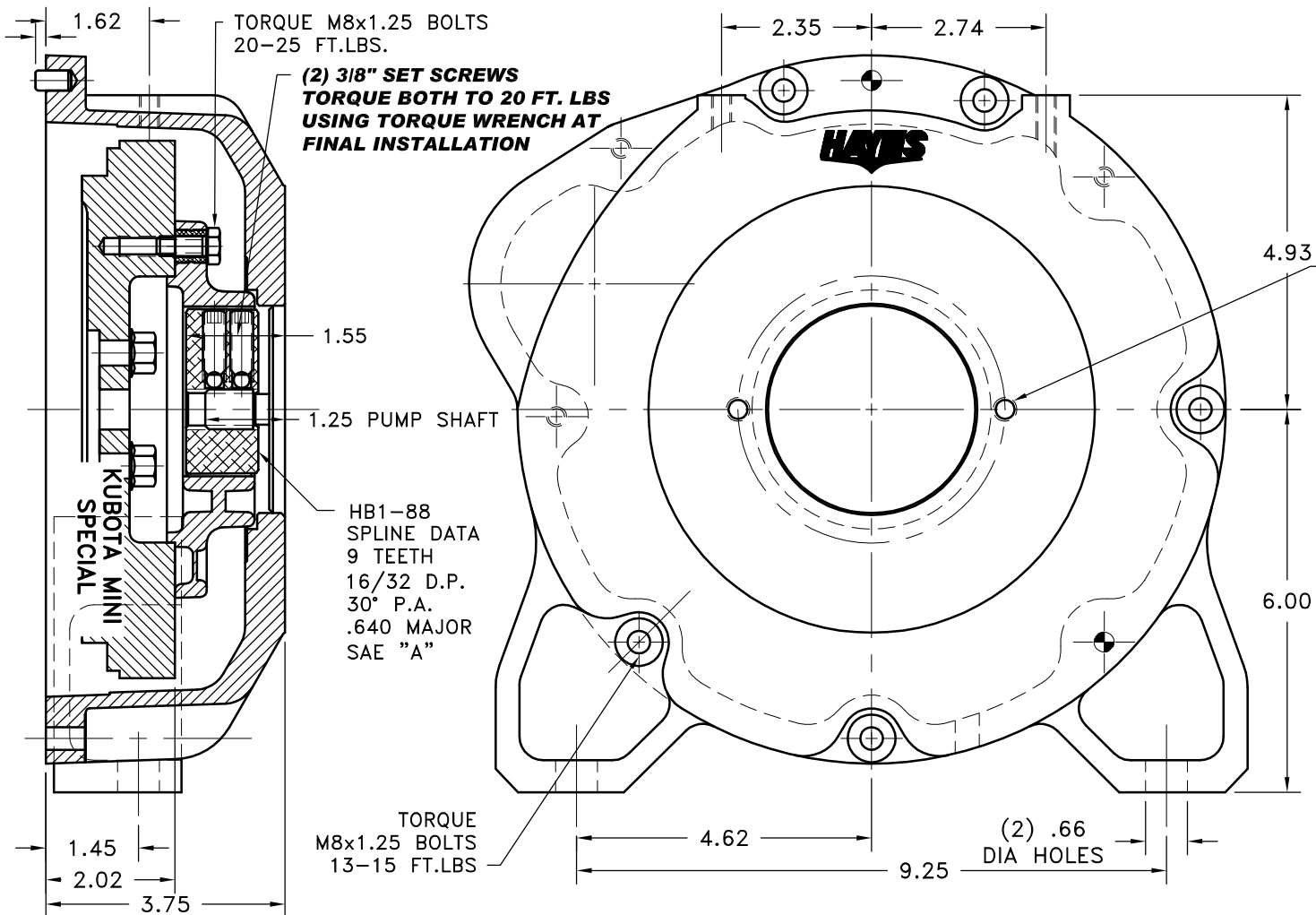

NOTE: THIS STEP IS IMPORTANT TO ENSURE FULL SPLINE ENGAGEMENT.

- 1) PRESET HUB ON SHAFT AS SHOWN.
- 2) IF YOUR PUMP SHAFT VARIES FROM THE DRAWN SHAFT LENGTH, CONTACT FACTORY FOR RECOMMENDATIONS.
- 3) **TORQUE BOTH SET SCREWS TO 25 FT.LBS. USING TORQUE WRENCH.**
- 4) SHAFT SHOULD HAVE FULL SPLINE ENGAGEMENT INTO HUB, IF NOT CONTACT FACTORY FOR RECOMMENDATIONS (231) 879-3372.

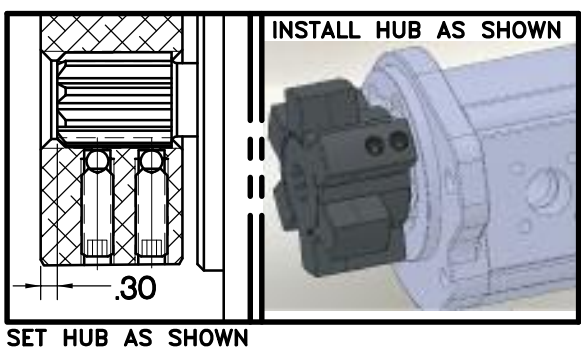

THIS DRAWING IS THE PROPERTY OF HAYES MFG. INC. AND IS LOANED SUBJECT TO THE CONDITION THAT IT SHALL NOT BE REPRODUCED, COPIED, LOANED OR OTHERWISE DISPOSED OF, DIRECTLY OR INDIRECTLY. IT SHALL BE USED AS A MEANS OF REFERENCE TO WORK FURNISHED BY THIS COMPANY ONLY AND IS NOT TO BE SUBMITTED TO OUTSIDE PARTIES FOR EXAMINATION WITHOUT OUR CONSENT.

5	930114-14	HOUSING	1
4	930112	BOLT KIT	1
3	PURCHASE	5/16 DIA x 1/2 DOWEL PIN	2
2	HB1-88	HEX~FLX HUB	1
1	B-SMN	HEX~FLX FLYWHEEL PLATE	1

SYMBOLS	DET.	PART NUMBER	DESCRIPTION	QTY.
▭ FLATNESS ▭ STRAIGHTNESS ▭ ANGULARITY ⊥ PERPENDICULARITY // PARALLELISM ⊙ CONCENTRICITY ⊕ TRUE POSITION ○ ROUNDNESS ⦶ CIRCULAR RUN OUT ⦶ TOTAL RUN OUT ⦶ CYLINDRICITY ⦶ FINISH	DO NOT SCALE DRAWING TOLERANCES UNLESS OTHERWISE SPECIFIED 1/32" MAXIMUM ANGLE ±1/2° FRACTION ±1/32 DECIMAL .00 ±.01 .000 ±.005 .0000 ±.0005			
TITLE KUBOTA MINI HEX~FLX COUPLING ASS'Y				
- UNLESS OTHERWISE SPECIFIED - REMOVE FIRST THREAD ON ALL TAPPED HOLES BREAK ALL SHARP CORNERS .010 TO .020 STAMP OR MARK DRAWING NO.		DRAWN BY SIETING	DATE 05-05-2009	DRAWING NO. 045-0-HB1-88-A2
		CHECKED BY	SCALE	SHEET OF REV.