

| REV | DATE | CHANGE DESCRIPTION | MOD.BY | CK1 | CK2 |
|-----|------------|------------------------------|--------|-----|-----|
| B | 02/12/2010 | CHANGED TO 1011 WOODRUFF KEY | ZS | | |

NOTES:

- WARNING!!!** INJURY OR DEATH FROM A ROTATING STUB SHAFT CAN OCCUR IF A CONDITION EXISTS WHICH WOULD CAUSE THE SHAFT TO BREAK OR COME APART FROM ANY PART OF THE ASSEMBLY. DEPENDING UPON THE APPLICATION (FOR EXAMPLE, FAN, PULLEY, SHEAVE, ETC.), THE AREA AROUND THE STUB SHAFT MUST BE SUFFICIENTLY GUARDED SO THAT IN THE EVENT OF FAILURE, THE GUARD WILL CONTAIN ANY AIRBORNE PARTS.

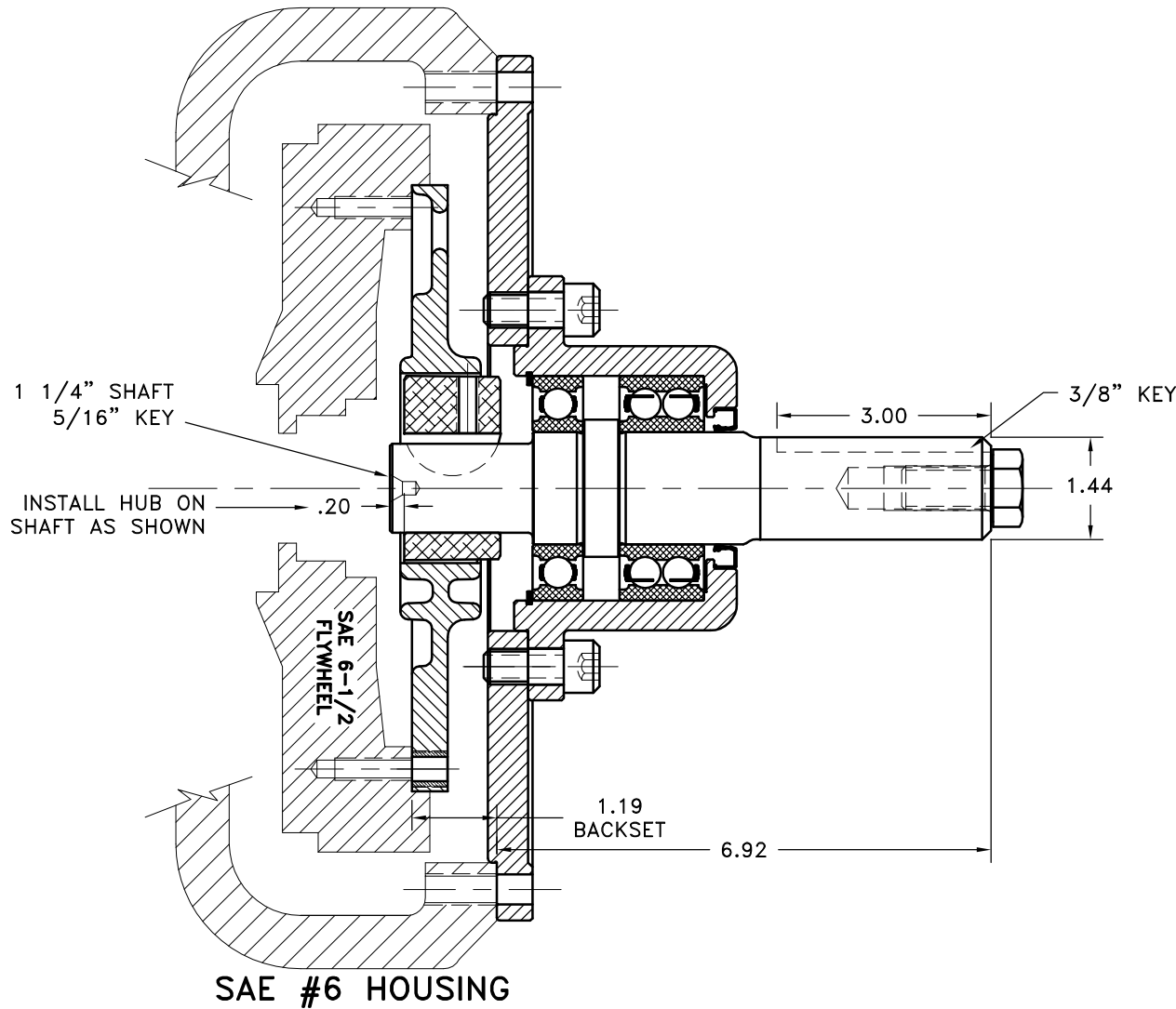

HUB/SHAFT ORIENTATION



THIS DRAWING IS THE PROPERTY OF HAYES MFG. INC. AND IS LOANED SUBJECT TO THE CONDITION THAT IT SHALL NOT BE REPRODUCED, COPIED, LOANED OR OTHERWISE DISPOSED OF, DIRECTLY OR INDIRECTLY. IT SHALL BE USED AS A MEANS OF REFERENCE TO WORK FURNISHED BY THIS COMPANY ONLY AND IS NOT TO BE SUBMITTED TO OUTSIDE PARTIES FOR EXAMINATION WITHOUT OUR CONSENT.

| SYMBOLS | DET. | PART NUMBER | DESCRIPTION | QTY. |
|---|--|-------------------------------|--|------|
| <ul style="list-style-type: none"> — FLATNESS — STRAIGHTNESS — ANGULARITY — PERPENDICULARITY — PARALLELISM — CONCENTRICITY — TRUE POSITION — ROUNDNESS — CIRCULAR RUN OUT — TOTAL RUN OUT — CYLINDRICITY — FINISH | DO NOT SCALE DRAWING TOLERANCES UNLESS OTHERWISE SPECIFIED .125/ MAXIMUM ANGLE ±1/2° FRACTION ±1/32 DECIMAL .00 ±.01 .000 ±.005 .0000 ±.0005 | | HAYES MANUFACTURING INC. ® TITLE BEARING SUPPORTED STUB SHAFT ASS'Y MATERIAL | |
| — UNLESS OTHERWISE SPECIFIED — REMOVE FIRST THREAD ON ALL TAPPED HOLES BREAK ALL SHARP CORNERS .010 TO .020 STAMP OR MARK DRAWING NO. | DRAWN BY SIETING CHECKED BY RJH | DATE 10-13-05 SCALE | DRAWING NO. 143-065-06-S SHEET OF REV. | |