

DAIHATSU STARTER PLATE

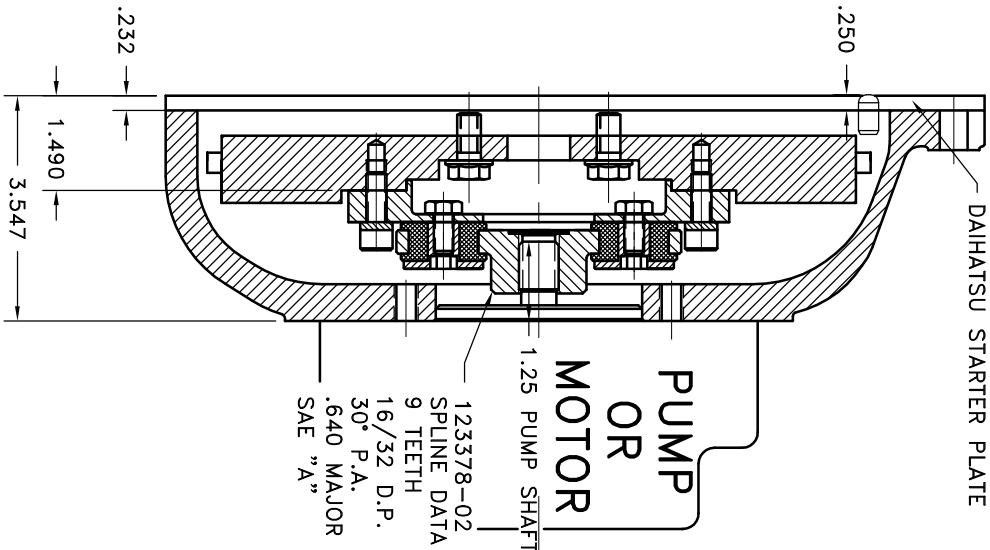

PUMP OR MOTOR
 1.25 PUMP SHAFT
 123378-02
 SPLINE DATA
 9 TEETH
 16/32 D.P.
 30° P.A.
 .640 MAJOR
 SAE "A"

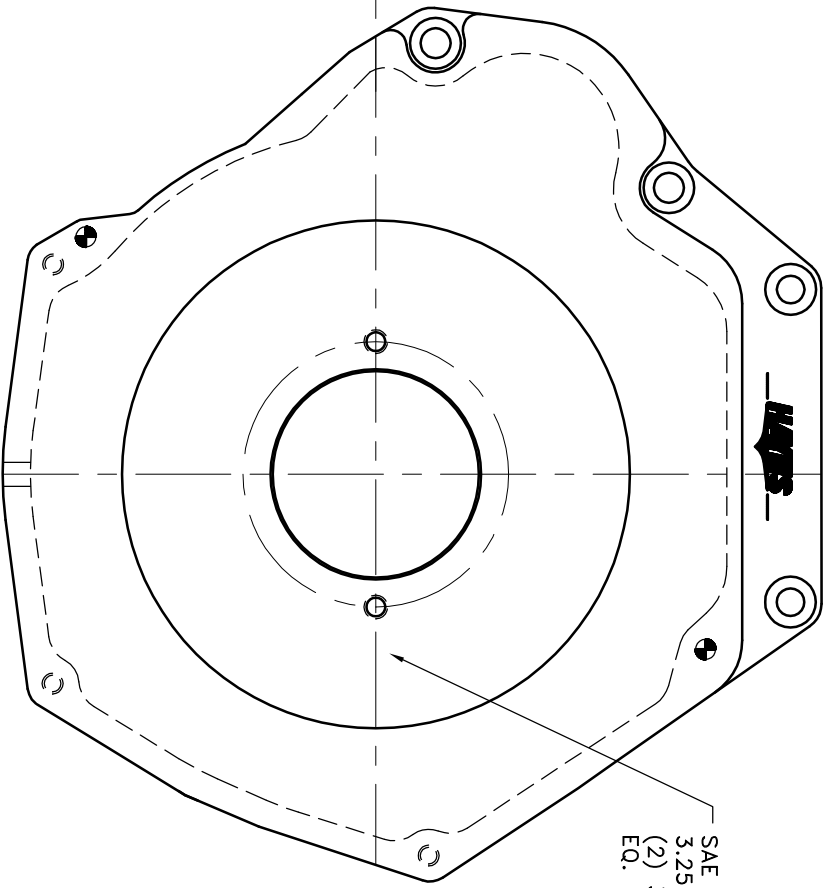

SAE "A" 2-BOLT MOUNT
 3.25 DIA PUMP PILOT
 (2) 3/8-16 TAPPED HOLES
 EQ. SPACED ON 4.187 B.C.

**NOTE: TORQUE ALL M10 HOUSING BOLTS 29-33 FT.LBS.
 TORQUE ALL M8 HOUSING BOLTS 13-15 FT.LBS.
 TORQUE ALL M8 FLYWHEEL BOLTS 20-25 FT.LBS.**

NOTES:

1. HOUSING FOR DAIHATSU ENGINES DM700G & DM950G
2. USE FURNISHED TEXACO 1912 COUPLING GREASE ON BOTH INTERNAL & EXTERNAL SPLINES.
3. CAUTION: WHEN INSTALLING PUMP ON ENGINE HOUSING BE CAREFUL BOLTS DO NOT EXTEND PAST INSIDE FACE OF HOUSING AND RUB ON COUPLING ASS'Y.

**COUPLING ASS'Y
 #126891**

UP TO 50 HP

QTY.	PART NUMBER	DESCRIPTION
1	123394	FLYWHEEL PLATE
1	123378-02	COUPLING HUB
6	HX100	5/16-24 x 5/8" HB
6	123729-01	THREADED BUSHING
6	H52500	NEOPRENE INSERT
1	801912	GREASE
1	HP-937-S-32	HUBBARD PLUG
1	969001-04	HOUSING
2	959001	BOLT KIT
1	969001	PURCHASE

REV.	DATE	CHANGE DESCRIPTION	MOD. BY	CK1	CK2

SYMBOLS

- STRAIGHTNESS
- ∠ ANGULARITY
- ⊥ PERPENDICULARITY
- ⊘ PARALLELISM
- ⊙ PERPENDICULARITY
- ⊙ TRUE POSITION
- ⊙ ROUNDNESS
- ⊙ CIRCULAR RUN OUT
- ⊙ TOTAL RUN OUT
- ⊙ CYLINDRICITY

— FINISH
 — UNLESS OTHERWISE SPECIFIED —
 BREAK ALL SHARP CORNERS .010 TO .020
 ON ALL TAPPED HOLES
 STAMP OR MARK DRAWING NO.

DO NOT SCALE DRAWING
 TOLERANCES UNLESS OTHERWISE SPECIFIED
 1/16" MINIMUM
 1/32" MAXIMUM
 FRACTIONS 3/16, 1/32
 DECIMAL .00 ± .005
 .00 ± .01
 .000 ± .005

HAYES
 MANUFACTURING INC. ©

DATE: 08-14-02
 DRAWN BY: []
 CHECKED BY: []
 SCALE: []
 SHEET 969005 OF [] REV. []

THIS DRAWING IS THE PROPERTY OF HAYES MFG. INC. AND IS LOANED TO YOU FOR YOUR INFORMATION ONLY. IT SHALL BE USED AS A MEANS OF REFERENCE TO WORK FURNISHED BY HAYES MANUFACTURING INC. AND NOT BE SUBMITTED TO OUTSIDE PARTIES FOR EXAMINATION WITHOUT OUR CONSENT.