

REV	DATE	CHANGE DESCRIPTION	MOD.BY	CK1	CK2

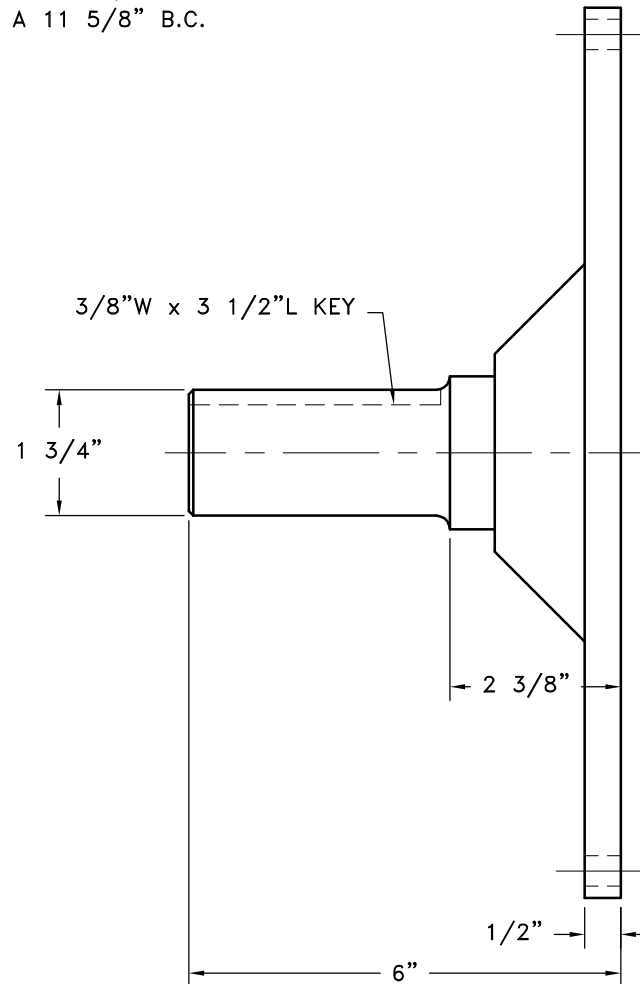
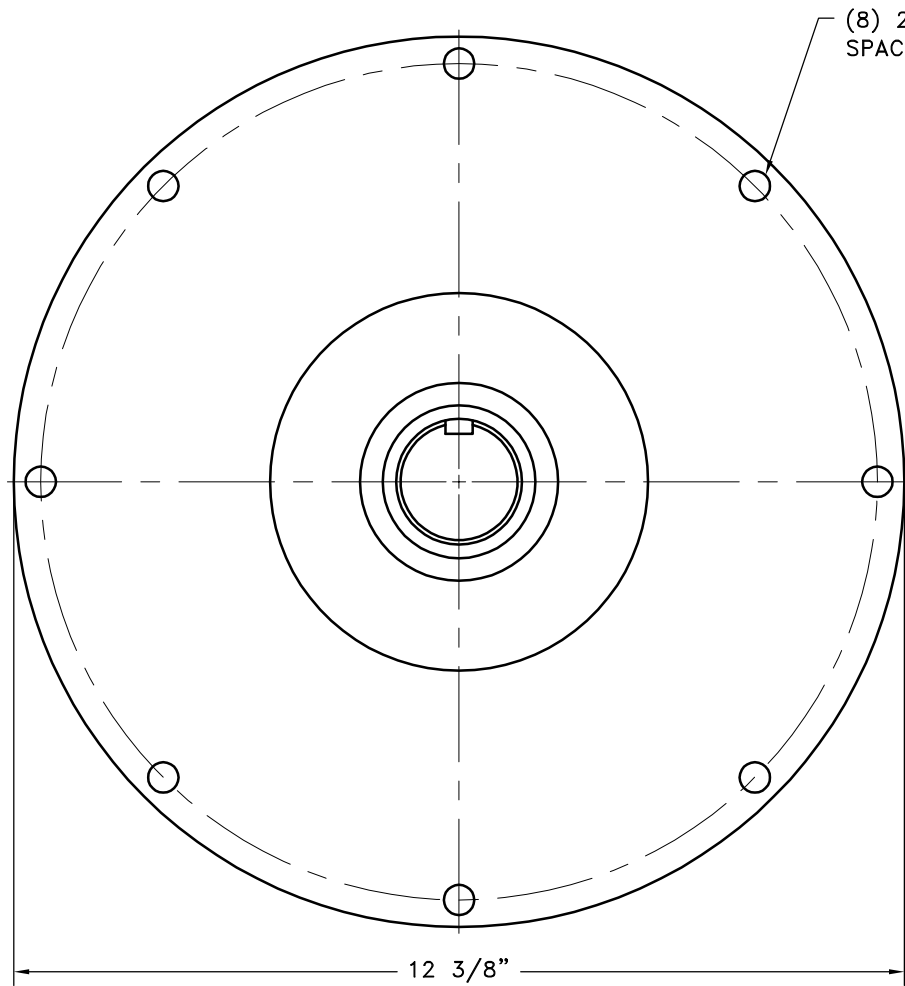

S.A.E. 10 STUB SHAFT

THIS DRAWING IS THE PROPERTY OF HAYES MFG. INC. AND IS LOANED SUBJECT TO THE CONDITION THAT IT SHALL NOT BE REPRODUCED, COPIED, LOANED OR OTHERWISE DISPOSED OF, DIRECTLY OR INDIRECTLY. IT SHALL BE USED AS A MEANS OF REFERENCE TO WORK FURNISHED BY THIS COMPANY ONLY AND IS NOT TO BE SUBMITTED TO OUTSIDE PARTIES FOR EXAMINATION WITHOUT OUR CONSENT.

SYMBOLS	DET.	PART NUMBER	DESCRIPTION	QTY.
<ul style="list-style-type: none"> — FLATNESS — STRAIGHTNESS — ANGULARITY — SQUARENESS — PARALLELISM — CONCENTRICITY — TRUE POSITION — ROUNDNESS — CIRCULAR RUN OUT — TOTAL RUN OUT — CYLINDRICITY — FINISH 	DO NOT SCALE DRAWING TOLERANCES UNLESS OTHERWISE SPECIFIED 125 MAXIMUM ANGLE ±1/2° FRACTION ±1/32 DECIMAL .00 ±.01 .000 ±.005 .0000 ±.0005			
			TITLE S.A.E. 10 STUB SHAFT	
			MATERIAL	
			DRAWN BY SIETING	DATE 06-22-06
			CHECKED BY R/JH	SCALE
				DRAWING NO. 26-02G54
				SHEET OF REV.