

REV	DATE	CHANGE DESCRIPTION	MOD.BY	CK1	CK2

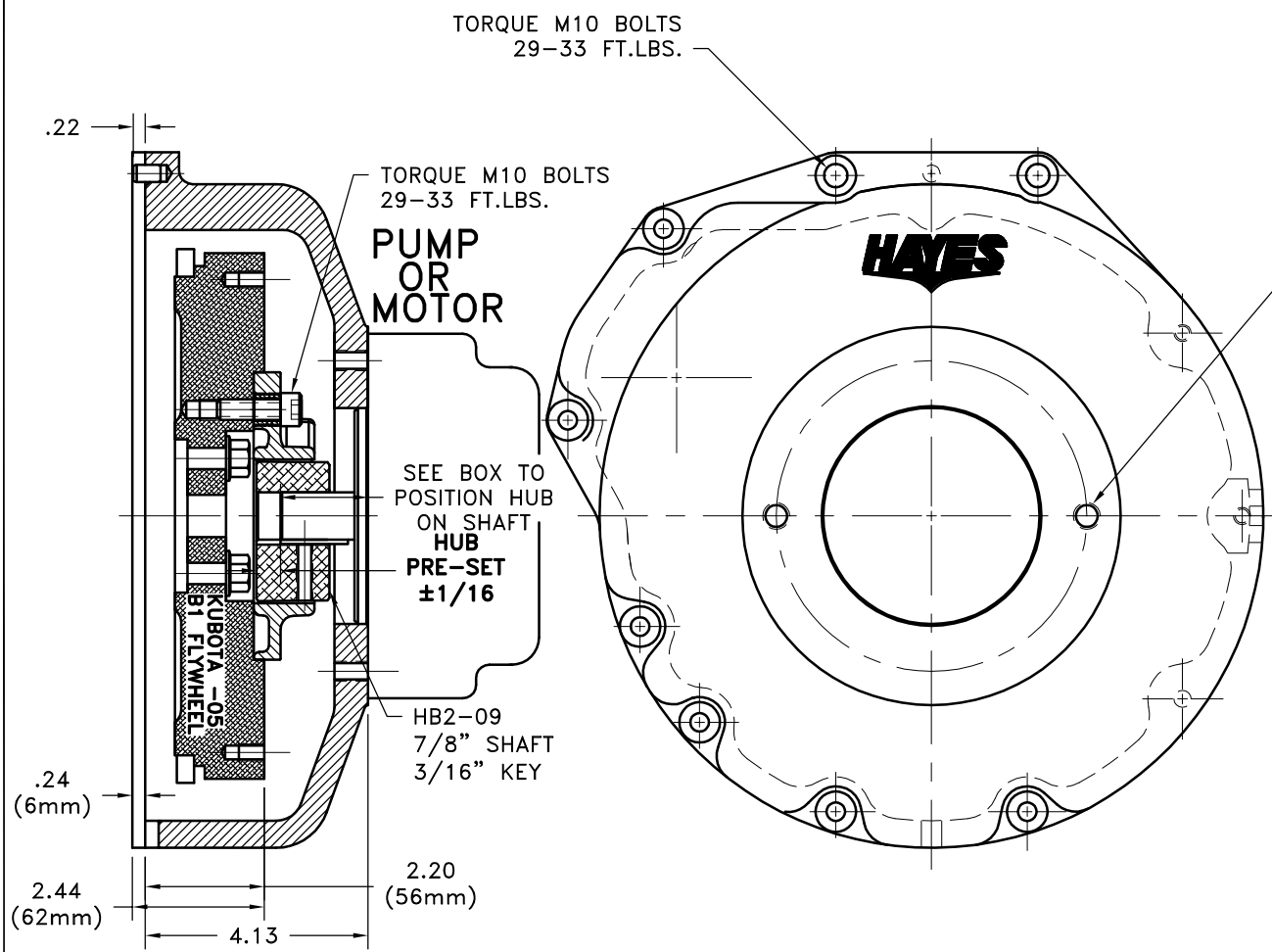

S.A.E. B 2-BOLT MOUNT  
 4.00" PILOT  
 (2) 1/2-13 TAPPED HOLES  
 EQ. SPACED ON A 5.75 B.C.

NOTES:

- HOUSING FOR KUBOTA ENGINES  
 D-905, D1005-B, D1105-B, V1205-B,  
 V1305-P, AND V1505-B.

**IMPORTANT INSTALLATION NOTE!!!!**

IMPROPER INSTALLATION OF HUB COULD CAUSE PREMATURE WEAR AND OR FAILURE.

IF YOU HAVE QUESTIONS CONCERNING LOCATION OF METAL HUB ON PUMP SHAFT PLEASE CONTACT DISTRIBUTOR OR FACTORY FOR FURTHER INFORMATION.

**BOTH HUB SET SCREWS MUST BE PROPERLY TORQUED TO 25 FT.LBS. USING TORQUE WRENCH . PLEASE CONTACT DISTRIBUTOR OR FACTORY FOR ANY FURTHER QUESTIONS.**

NOTE: REMOVE HUB FROM ASS'Y, PRESET HUB ON SHAFT AS SHOWN. **TORQUE BOTH SET SCREWS TO 25 FT.LBS. USING TORQUE WRENCH.** SHAFT SHOULD HAVE A MINIMUM OF 3/4" OF ENGAGEMENT IF NOT CONTACT FACTORY FOR RECOMMENDATIONS (231) 879-3372 TO GET HUB PRESET USE THIS EQUATION:  
**PERFORM CALCULATION BELOW:**

**2.07- SHAFT LENGTH - HUB PRESET**

IF YOUR ANSWER IS (+) SHAFT IS INSIDE OF HUB, IF YOUR ANSWER IS (-) SHAFT STICKS OUT OF HUB. (SEE BOXES)

NOTE: THIS STEP IS IMPORTANT TO ENSURE FULL SHAFT ENGAGEMENT.

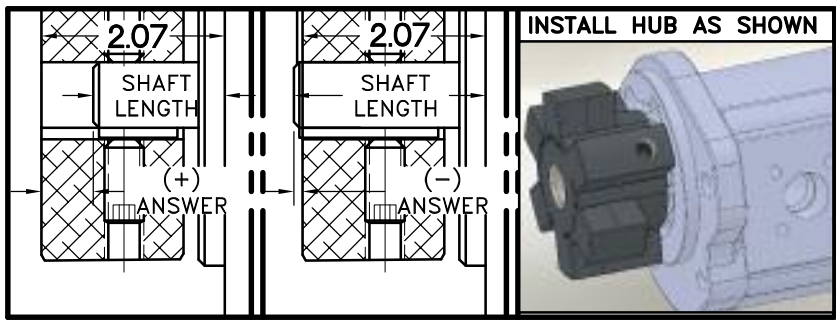

B-S05-HB2-09

6	BLACK PLUG	C-32-U-200 OR C36-2-U-2000	1
5	952182	BOLT KIT	1
4	PURCHASE	5/16 DIA x 1/2 DOWEL PIN	2
3	952055-02	HOUSING	1
2	HB2-09	HEX~FLX HUB	1
1	B-S05	HEX~FLX DRIVE PLATE	1

SYMBOLS	DET.	PART NUMBER	DESCRIPTION	QTY.
▭ FLATNESS ▭ STRAIGHTNESS ▭ ANGULARITY ⊥ PERPENDICULARITY ∥ PARALLELISM ⊙ CONCENTRICITY ⊕ TRUE POSITION ○ ROUNDNESS ⊖ CIRCULAR RUN OUT ⊖ TOTAL RUN OUT ⌀ CYLINDRICITY ⌒ FINISH	DO NOT SCALE DRAWING TOLERANCES UNLESS OTHERWISE SPECIFIED 1/32" MAXIMUM ANGLE ±1/2° FRACTION ±1/32 DECIMAL .00 ±.01 .000 ±.005 .0000 ±.0005			
<b>TITLE</b> KUBOTA -05 HEX~FLX ASS'Y				
<b>MATERIAL</b>				
- UNLESS OTHERWISE SPECIFIED - REMOVE FIRST THREAD ON ALL TAPPED HOLES BREAK ALL SHARP CORNERS .010 TO .020 STAMP OR MARK DRAWING NO.		DRAWN BY SIETING	DATE 08-06-07	DRAWING NO. 006-0-HB2-09-B2
		CHECKED BY RJH	SCALE	SHEET OF REV.

THIS DRAWING IS THE PROPERTY OF HAYES MFG. INC. AND IS LOANED SUBJECT TO THE CONDITION THAT IT SHALL NOT BE REPRODUCED, COPIED, LOANED OR OTHERWISE DISPOSED OF, DIRECTLY OR INDIRECTLY. IT SHALL BE USED AS A MEANS OF REFERENCE TO WORK FURNISHED BY THIS COMPANY ONLY AND IS NOT TO BE SUBMITTED TO OUTSIDE PARTIES FOR EXAMINATION WITHOUT OUR CONSENT.