

REV	DATE	CHANGE DESCRIPTION	MOD.BY	CK1	CK2
A	10/03/2006	CHANGED HOUSING P/N	ZS	ML	HM

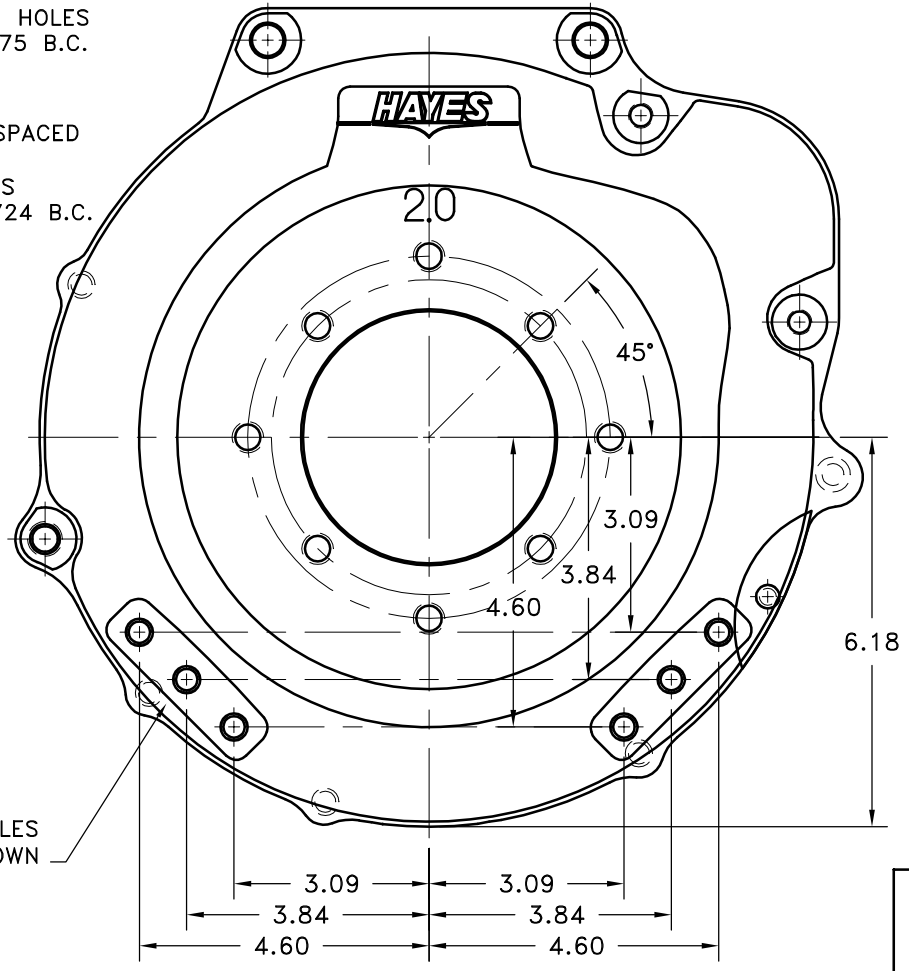
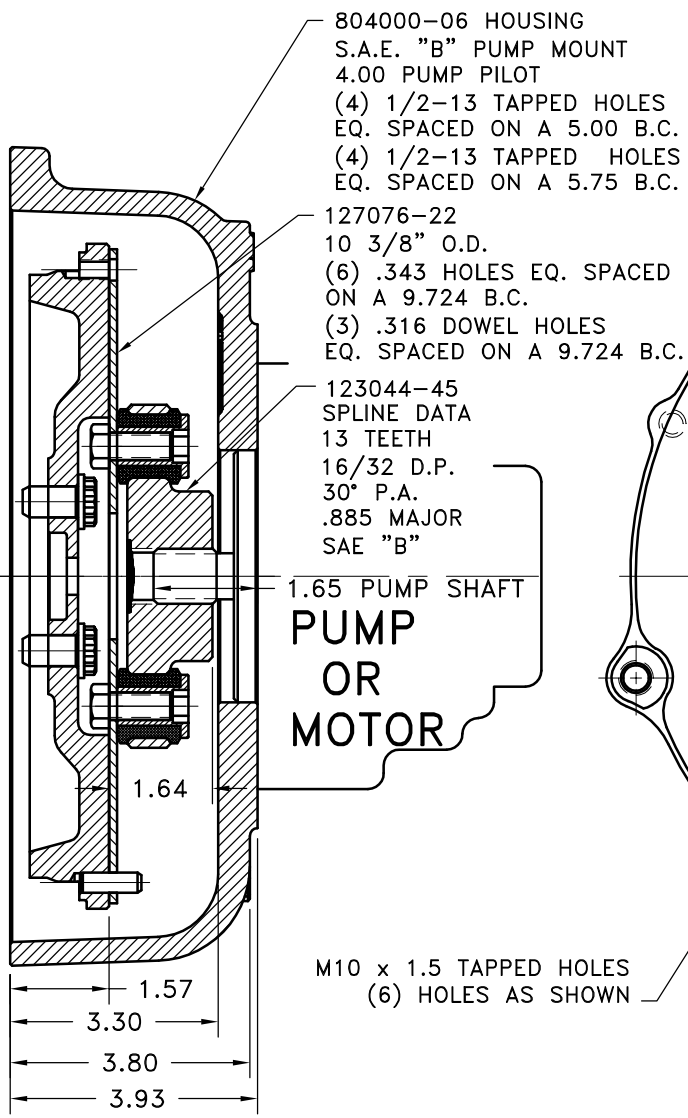

M10 x 1.5 TAPPED HOLES
(6) HOLES AS SHOWN

COUPLING ASS'Y #127903

9	804002	BOLT KIT	1
8	804000-06	HOUSING	1
7	801912	GREASE	1
6	HP-1125-S-32	GREASE PLUG	1
5	HX200	7/16-20 x 1" HHB	6
4	H62500	NEOPRENE INSERT	6
3	123727	THREADED BUSHING	6
2	123044-45	COUPLING HUB	1
1	127076-22	FLYWHEEL PLATE	1

SYMBOLS	DET.	PART NUMBER	DESCRIPTION	QTY.
▨ FLATNESS — STRAIGHTNESS ∠ ANGULARITY ⊥ SQUARENESS ∥ PARALLELISM ⊙ CONCENTRICITY ⊕ TRUE POSITION ○ ROUNDNESS ⊖ CIRCULAR RUN OUT ⊖ TOTAL RUN OUT ⊖ CYLINDRICITY √ FINISH	DO NOT SCALE DRAWING TOLERANCES UNLESS OTHERWISE SPECIFIED 125 MAXIMUM ANGLE ±1/2° FRACTION ±1/32 DECIMAL .00 ±.01 .000 ±.005 .0000 ±.0005			
- UNLESS OTHERWISE SPECIFIED - REMOVE FIRST THREAD ON ALL TAPPED HOLES BREAK ALL SHARP CORNERS .010 TO .020 STAMP OR MARK DRAWING NO.		DRAWN BY SIETING	DATE 06-01-05	DRAWING NO. 804003 SHEET OF REV.

THIS DRAWING IS THE PROPERTY OF HAYES MFG. INC. AND IS LOANED SUBJECT TO THE CONDITION THAT IT SHALL NOT BE REPRODUCED, COPIED, LOANED OR OTHERWISE DISPOSED OF, DIRECTLY OR INDIRECTLY. IT SHALL BE USED AS A MEANS OF REFERENCE TO WORK FURNISHED BY THIS COMPANY ONLY AND IS NOT TO BE SUBMITTED TO OUTSIDE PARTIES FOR EXAMINATION WITHOUT OUR CONSENT.