

REV	DATE	CHANGE DESCRIPTION	MOD.BY	CK1	CK2
B	10/03/2006	CHANGED HOUSING P/N	ZS	ML	HM

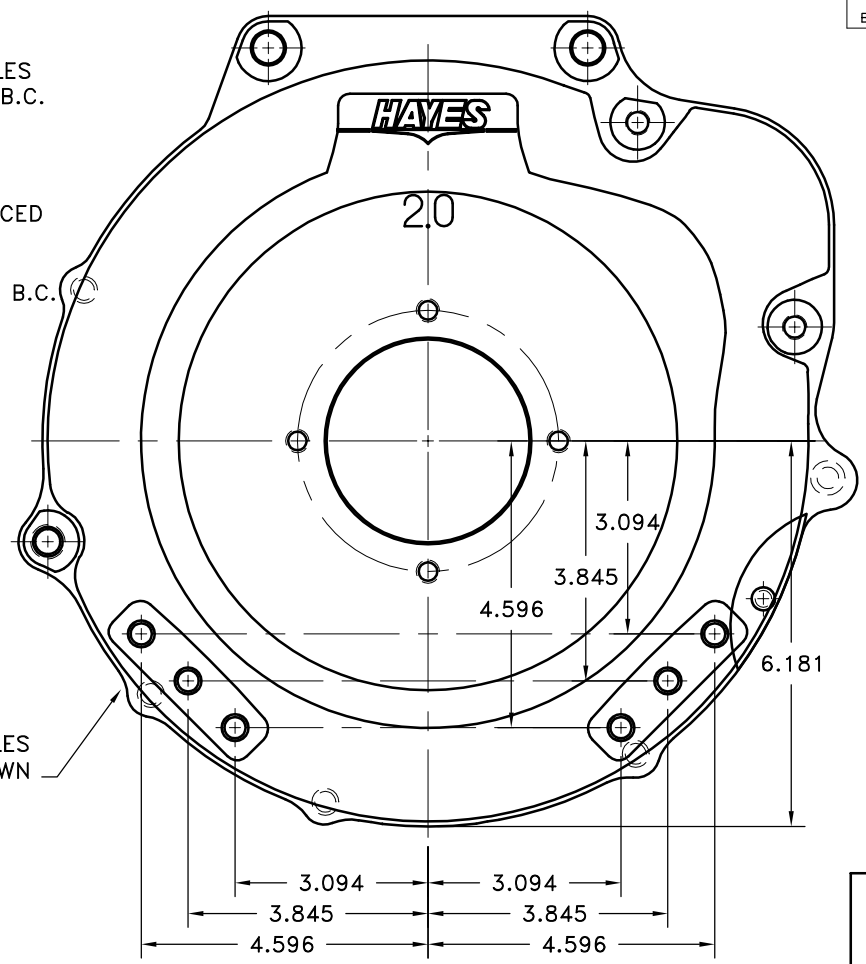
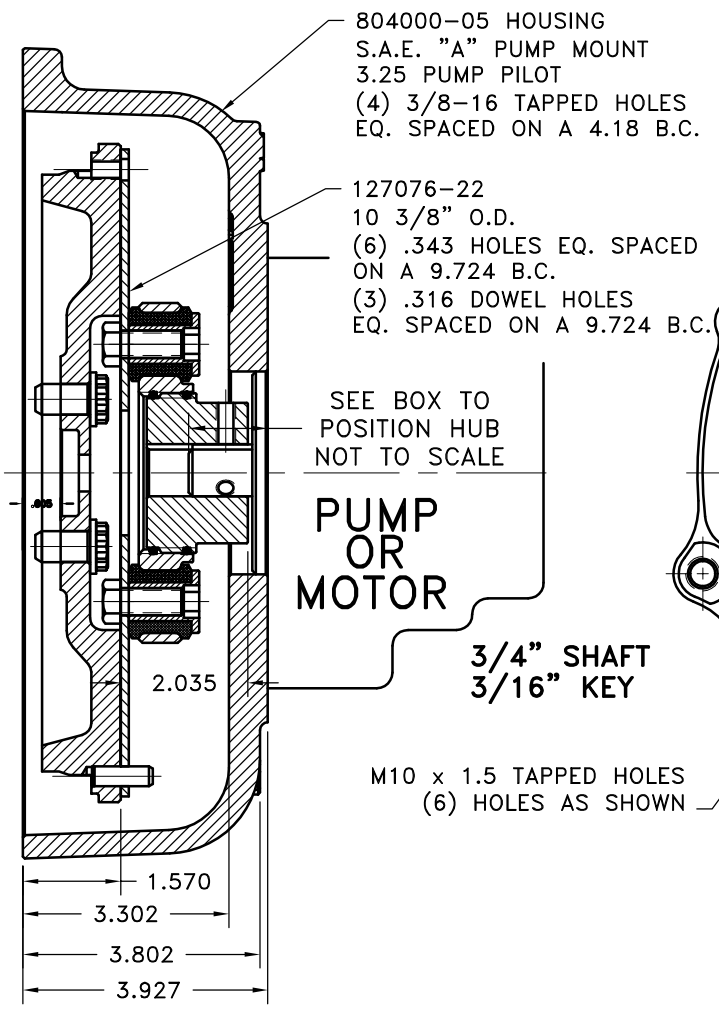

13	804002	BOLT KIT	1
12	804000-05	HOUSING	1
11	801912	GREASE	1
10	PURCHASE	5/16-18 x 3/4\" SSSCP	1
9	PURCHASE	5/16-18 x 5/8\" SSSCP	1
8	568-143	O-RING (124473)	1
7	568-142	O-RING (128037-07)	1
6	HX200	7/16-20 x 1\" HHB	6
5	H62500	NEOPRENE INSERT	6
4	123727	THREADED BUSHING	6
3	128037-07	EXT. SPL HUB [3/4S\3/16K]	1
2	124473	COUPLING HUB	1
1	127076-22	FLYWHEEL PLATE	1

NOTE: REMOVE HUB FROM ASS'Y, PRESET HUB ON SHAFT & REASSEMBLE USING NUT & BOLT GRADE LOC-TITE ON SET SCREWS. SHAFT SHOULD HAVE A MINIMUM OF 3/4\" OF ENGAGEMENT IF NOT CONTACT FACTORY FOR RECOMMENDATIONS. TO GET HUB PRESET USE THIS EQUATION:

EXAMPLE:  
1.94 - SHAFT LENGTH = HUB PRESET

IF YOUR ANSWER IS (+) SHAFT IS INSIDE OF HUB, IF YOUR ANSWER IS (-) SHAFT STICKS OUT OF HUB. (SEE BOXES)

THIS DRAWING IS THE PROPERTY OF HAYES MFG. INC. AND IS LOANED SUBJECT TO THE CONDITION THAT IT SHALL NOT BE REPRODUCED, COPIED, LOANED OR OTHERWISE DISPOSED OF, DIRECTLY OR INDIRECTLY. IT SHALL BE USED AS A MEANS OF REFERENCE TO WORK FURNISHED BY THIS COMPANY ONLY AND IS NOT TO BE SUBMITTED TO OUTSIDE PARTIES FOR EXAMINATION WITHOUT OUR CONSENT.

NOTE: THIS STEP IS IMPORTANT TO ENSURE FULL SPLINE ENGAGEMENT.

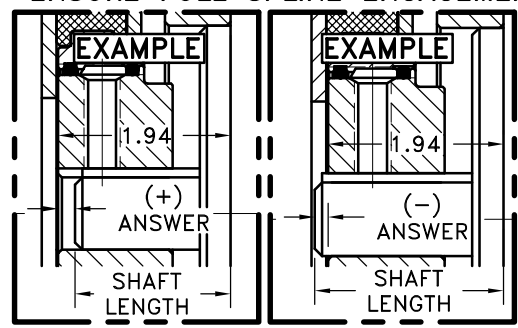

COUPLING ASS'Y #128017

SYMBOLS	DET.	PART NUMBER	DESCRIPTION	QTY.
<ul style="list-style-type: none"> <li>— FLATNESS</li> <li>— STRAIGHTNESS</li> <li>— ANGULARITY</li> <li>— SQUARENESS</li> <li>— PARALLELISM</li> <li>— CONCENTRICITY</li> <li>— TRUE POSITION</li> <li>— ROUNDNESS</li> <li>— CIRCULAR RUN OUT</li> <li>— TOTAL RUN OUT</li> <li>— CYLINDRICITY</li> <li>— FINISH</li> </ul>	DO NOT SCALE DRAWING TOLERANCES UNLESS OTHERWISE SPECIFIED 125 MAXIMUM ANGLE ±1/2° FRACTION ±1/32 DECIMAL .00 ±.01 .000 ±.005 .0000 ±.0005			
- UNLESS OTHERWISE SPECIFIED - REMOVE FIRST THREAD ON ALL TAPPED HOLES BREAK ALL SHARP CORNERS .010 TO .020 STAMP OR MARK DRAWING NO.		DRAWN BY SIETING CHECKED BY RJH	DATE 10-03-05 SCALE	DRAWING NO. 804005 SHEET OF REV.