

REV	DATE	CHANGE DESCRIPTION	MOD.BY	CK1	CK2

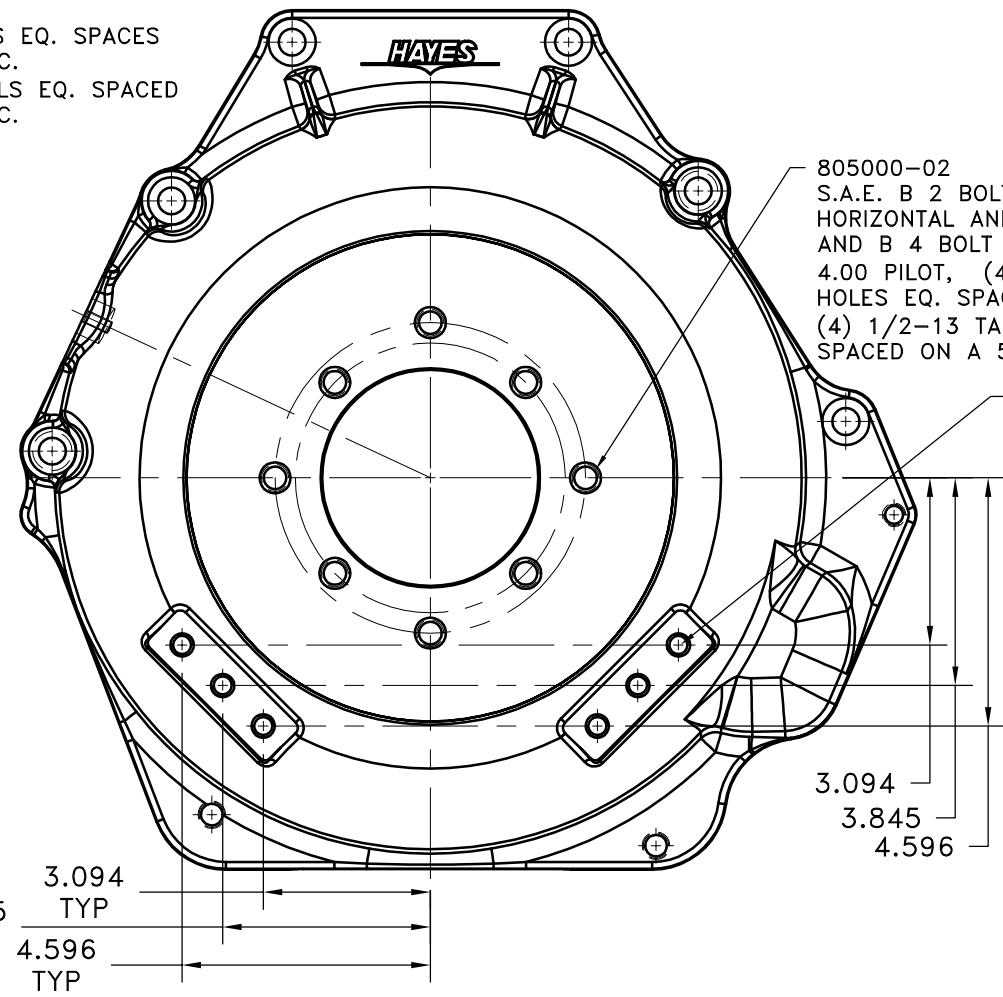
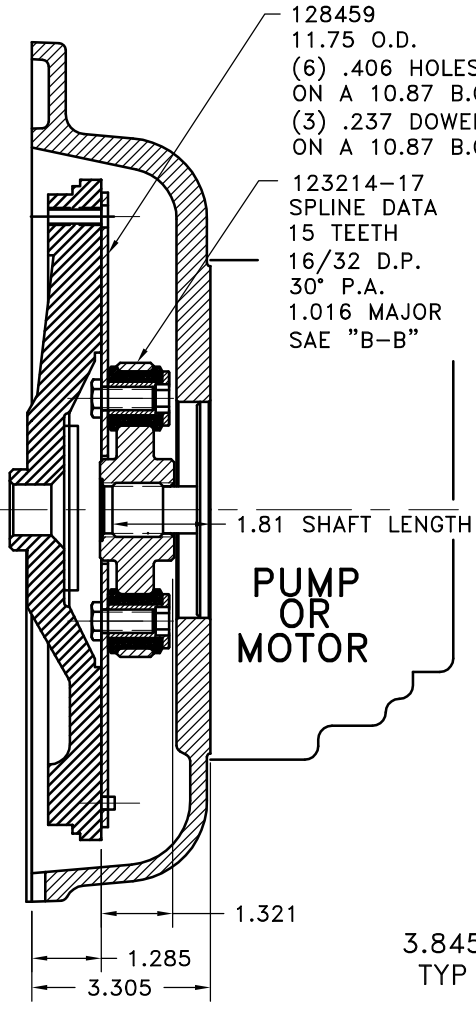

COUPLING ASS'Y #128460

9	805002	BOLT KIT	1
8	805000-02	HOUSING	1
7	801912	GREASE	1
6	HP-1125-S-32	GREASE PLUG	1
5	HX210	SPEC. 7/16-20 x 1" HHB	6
4	123727	THREADED BUSHING	6
3	H62500	NEOPRENE INSERT	6
2	123214-17	COUPLING HUB	1
1	128459	FLYWHEEL PLATE	1

SYMBOLS	DET.	PART NUMBER	DESCRIPTION	QTY.
—	DO NOT SCALE			
—	FLATNESS			
—	STRAIGHTNESS			
—	ANGULARITY			
—	SQUARENESS			
—	PARALLELISM			
—	CONCENTRICITY			
—	TRUE POSITION			
—	ROUNDNESS			
—	CIRCULAR RUN OUT			
—	TOTAL RUN OUT			
—	CYLINDRICITY			
—	FINISH			
TOLERANCES UNLESS OTHERWISE SPECIFIED 1/2" MAXIMUM ANGLE ±1/2° FRACTION ±1/32 DECIMAL .00 ±.01 .000 ±.005 .0000 ±.0005				
- UNLESS OTHERWISE SPECIFIED - REMOVE FIRST THREAD ON ALL TAPPED HOLES BREAK ALL SHARP CORNERS .010 TO .020 STAMP OR MARK DRAWING NO.				
TITLE CHRYSLER 2.8L COUPLING AND HOUSING ASS'Y		DRAWN BY SIETING	DATE 11-28-06	DRAWING NO. 805004
MATERIAL		CHECKED BY RJH	SCALE	SHEET OF REV.

THIS DRAWING IS THE PROPERTY OF HAYES MFG. INC. AND IS LOANED SUBJECT TO THE CONDITION THAT IT SHALL NOT BE REPRODUCED, COPIED, LOANED OR OTHERWISE DISPOSED OF, DIRECTLY OR INDIRECTLY. IT SHALL BE USED AS A MEANS OF REFERENCE TO WORK FURNISHED BY THIS COMPANY ONLY AND IS NOT TO BE SUBMITTED TO OUTSIDE PARTIES FOR EXAMINATION WITHOUT OUR CONSENT.