

REV. NO.	SYM.	DATE	CHANGE DESCRIPTION	DWN.
	A	8/00	CHANGED TO BOLTED	RH

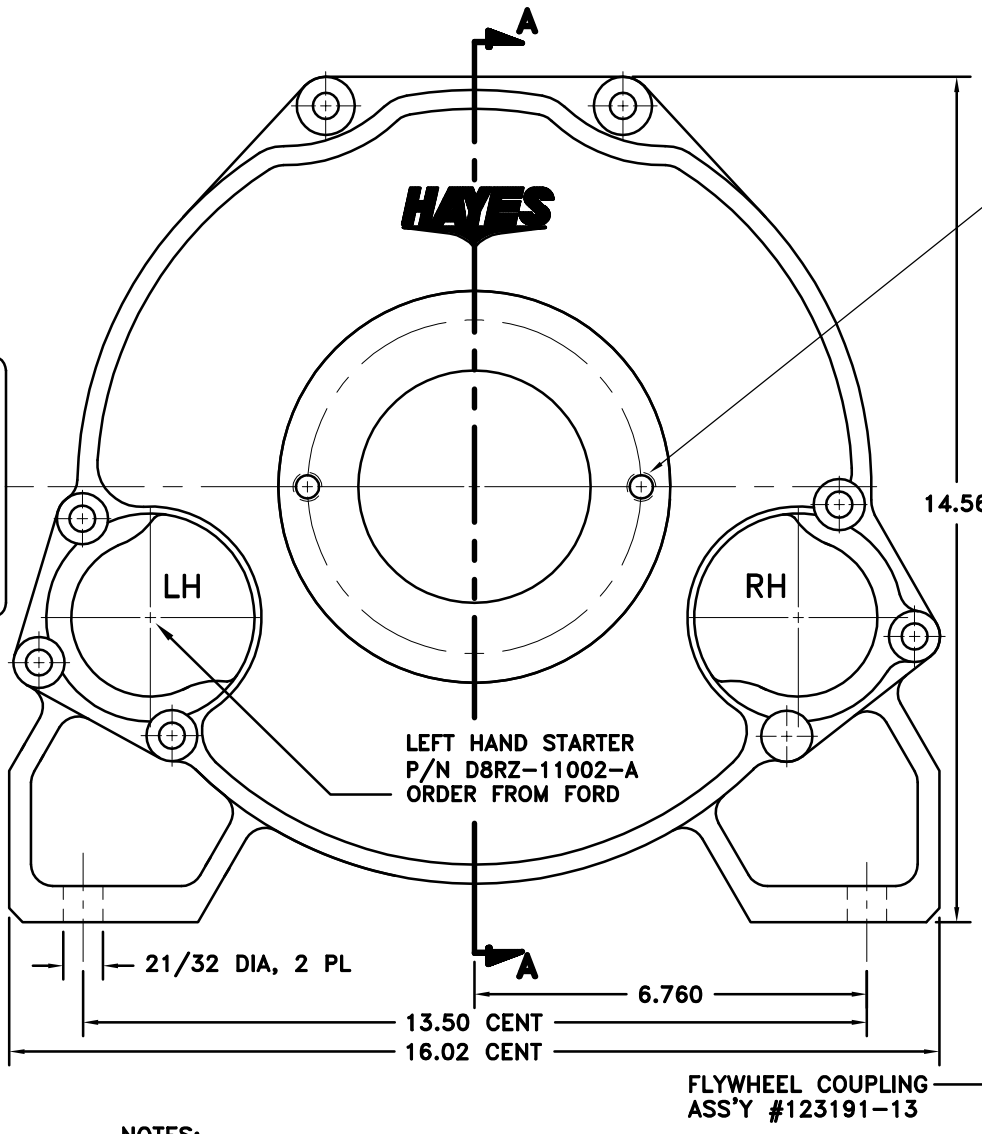
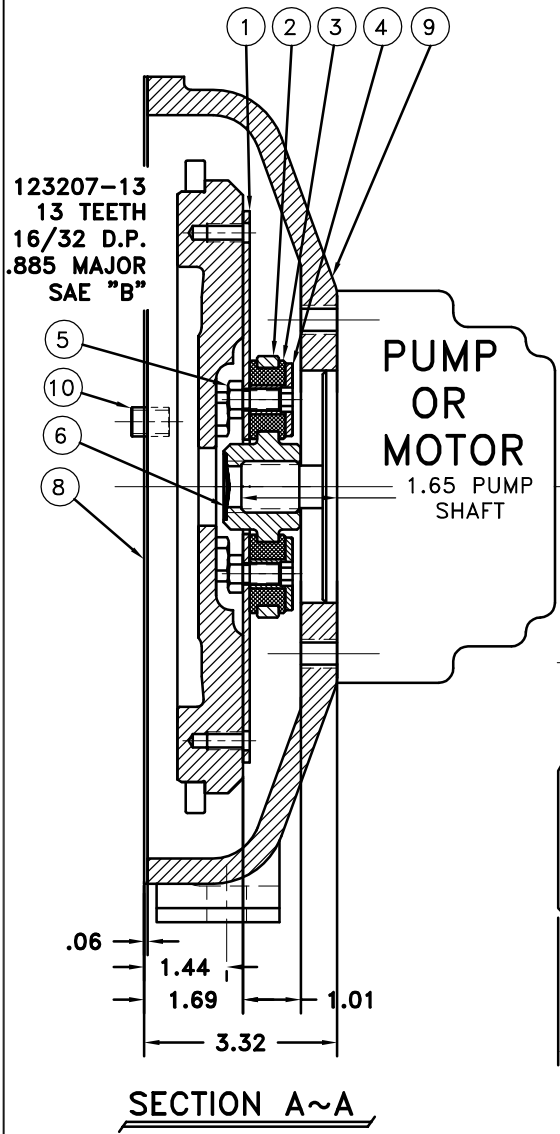

SAE "B" 2-BOLT MOUNT
4.00 DIA PUMP PILOT
(2) 1/2-13 TAPPED HOLES
EQ. SPACED ON 5.75 B.C.

UP TO 20 HP

10	70HM-6397-AA	DOWEL BUSHING (ORDER FROM FORD)	2
9	881994-B2	HOUSING	1
8	855265-LH	STARTER PLATE	1
7	801912	GREASE	1
6	HP-1125-S-32	HUBBARD PLUG	1
5	HX100	5/16-24x5/8 H.H.B.	3
4	123729-01	THREADED BUSHING	3
3	H52500	NEOPRENE INSERT	3
2	123207-13	COUPLING HUB	1
1	123205-01	FLYWHEEL PLATE	1

NOTES:

- HOUSING WILL FIT FORD ENGINE VSG-413, 4 CYLINDER, 1.3 LITER (79 CID)
- USE FURNISHED TEXACO 1912 COUPLING GREASE ON BOTH MALE AND FEMALE SPLINE.
- CAUTION: WHEN INSTALLING PUMP ON ENGINE HOUSING BE CAREFUL BOLTS DO NOT EXTEND PAST INSIDE FACE OF HOUSING AND RUB ON COUPLING ASSEMBLY.

THIS DRAWING IS THE PROPERTY OF HAYES MFG. INC. AND IS LOANED SUBJECT TO THE CONDITION THAT IT SHALL NOT BE REPRODUCED, COPIED, LOANED OR OTHERWISE DISPOSED OF, DIRECTLY OR INDIRECTLY. IT SHALL BE USED AS A MEANS OF REFERENCE TO WORK FURNISHED BY THIS COMPANY ONLY AND IS NOT TO BE SUBMITTED TO OUTSIDE PARTIES FOR EXAMINATION WITHOUT OUR CONSENT.

SYMBOLS ▭ FLATNESS ▭ STRAIGHTNESS ▭ ANGULARITY ⊥ SQUARENESS // PARALLELISM ◎ CONCENTRICITY ⊕ TRUE POSITION ○ ROUNDNESS ⊘ CIRCULAR RUN OUT ⊘ TOTAL RUN OUT ⊘ CYLINDRICITY ✓ FINISH	DET. PART NUMBER DESCRIPTION QTY. DO NOT SCALE DRAWING TOLERANCES UNLESS OTHERWISE SPECIFIED ANGLE ±1/2° FRACTION ±1/32 DECIMAL .00 ±.01 .000 ±.005 .0000 ±.0005		
	TITLE FORD VSG-413 HOUSING & FLYWHEEL COUPLING ASS'Y MATERIAL		DRAWN BY LANNEN DATE 3-30-94 CHECKED BY SCALE

- UNLESS OTHERWISE SPECIFIED -
REMOVE FIRST THREAD ON ALL TAPPED HOLES
BREAK ALL SHARP CORNERS .010 TO .020 STAMP OR MARK DRAWING NO.