

SYL.	DATE	CHANGED DESCRIPTION	DRW.

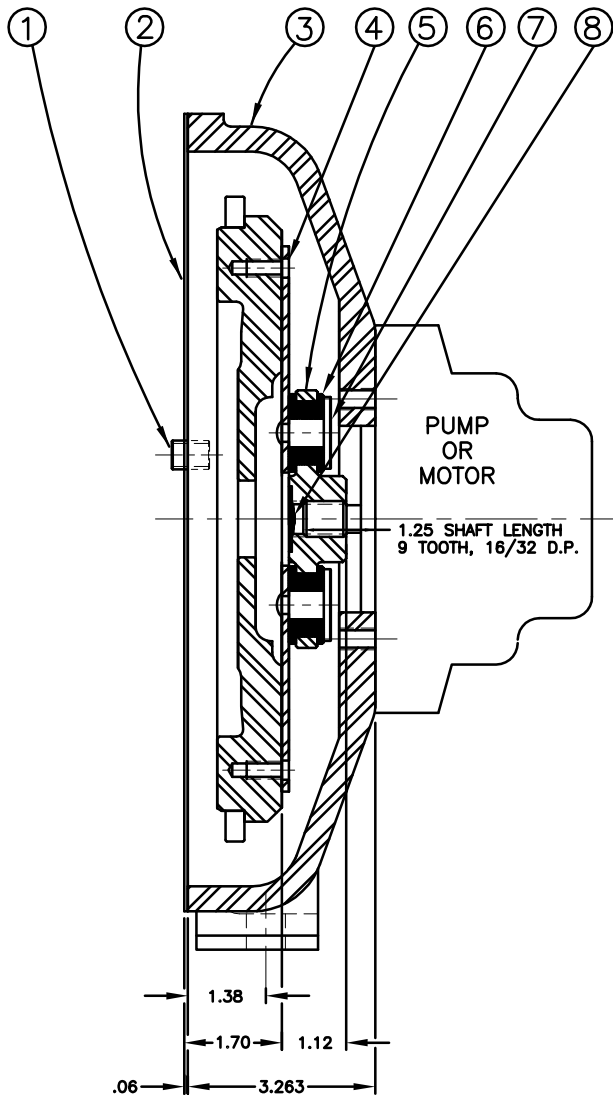

SECTION A~A

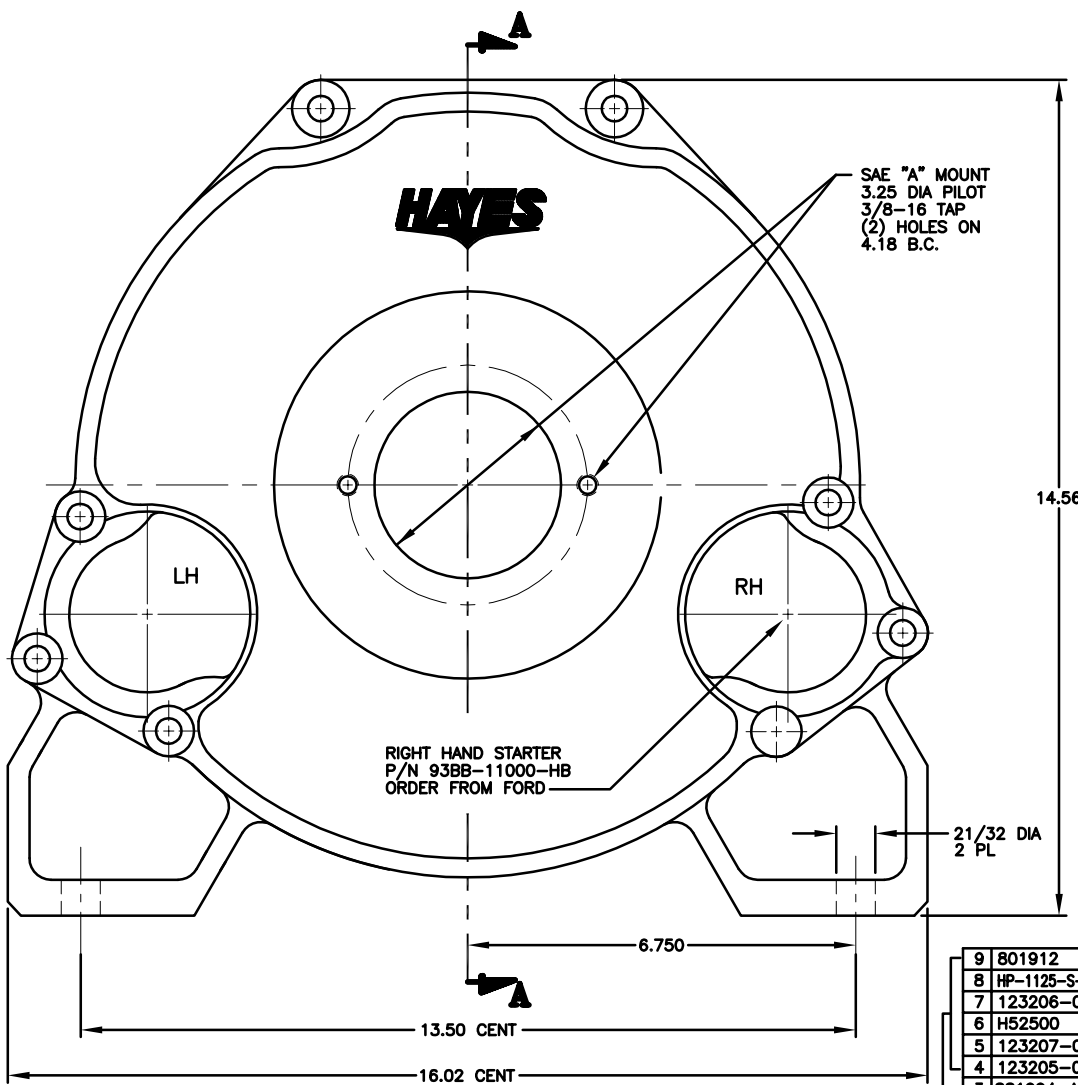

UP TO 50 H.P.

QTY.	PART NUMBER	DESCRIPTION
1	9 801912	GREASE
1	8 HP-1125-S-32	HUBBARD PLUG
6	7 123206-01	STEEL RIVET
6	6 H52500	NEOPRENE INSERT
1	5 123207-04	COUPLING HUB
1	4 123205-01	FLYWHEEL PLATE
1	3 881994-A2	ENGINE HOUSING
1	2 855136-RH	STARTER PLATE
2	1 70HM-6397-AA	DOWEL BUSHING

COUPLING ASS'Y #123840
ORDER FROM FORD

NOTE:

- HOUSING WILL FIT FORD ENGINE V5G-413, 4 CYLINDER, 1.3 LITER, (79 CID)
- USE FURNISHED TEXACO 1912 COUPLING GREASE ON BOTH MALE AND FEMALE SPLINE.
- CAUTION: WHEN INSTALLING PUMP ON ENGINE HOUSING BE CAREFUL BOLTS DO NOT EXTEND PAST INSIDE FACE OF HOUSING AND RUB ON COUPLING ASSEMBLY.

THIS DRAWING IS THE PROPERTY OF HAYES MFG. CO. AND IS LOANED SUBJECT TO THE CONDITION THAT IT SHALL NOT BE REPRODUCED, COPIED, LOANED OR OTHERWISE USED IN ANY MANNER WITHOUT THE WRITTEN CONSENT OF HAYES MFG. CO. IT SHALL BE USED AS A GUIDE OF REFERENCE TO THE PARTS LISTED THEREON ONLY AND IS NOT TO BE SUBMITTED TO OUTSIDE PARTS FOR CONSTRUCTION WITHOUT OUR CONSENT.

SYMBOLS	DEF.	PART NUMBER	DESCRIPTION	QTY.
FLATNESS	DO NOT SCALE			
STRAIGHTNESS	DRAWING			
ANGULARITY				
ROUNDNESS				
PARALLELISM				
PERPENDICULARITY				
CONCENTRICITY				
TRUE POSITION				
SYMMETRY				
LOC. SURFACE				
ROUNDNESS				
FINISH				

UNLESS OTHERWISE SPECIFIED - FINISH: ALL SHARP CORNERS 0.10 TO 0.20 RADIUS OR AS SHOWN ON DRAWING NO.

DRAWN BY: LANNEN
 DATE: 3-30-94
 CHECKED BY: SOLE
 DIVISION NO.: 866713
 SHEET OF: FULL