

REV	DATE	CHANGE DESCRIPTION	MOD BY	CK1	CK2

SUPPLIED IN BOLT KIT  
GM PN 838653 BOLT  
6 PIECES

SENSOR HOLE  
5/8-18 THREAD

SAE "C" 4-BOLT MOUNT  
5.00 PUMP PILOT  
(4) 1/2-13 TAPPED HOLES  
EQ. SPACED ON 6.375 B.C.

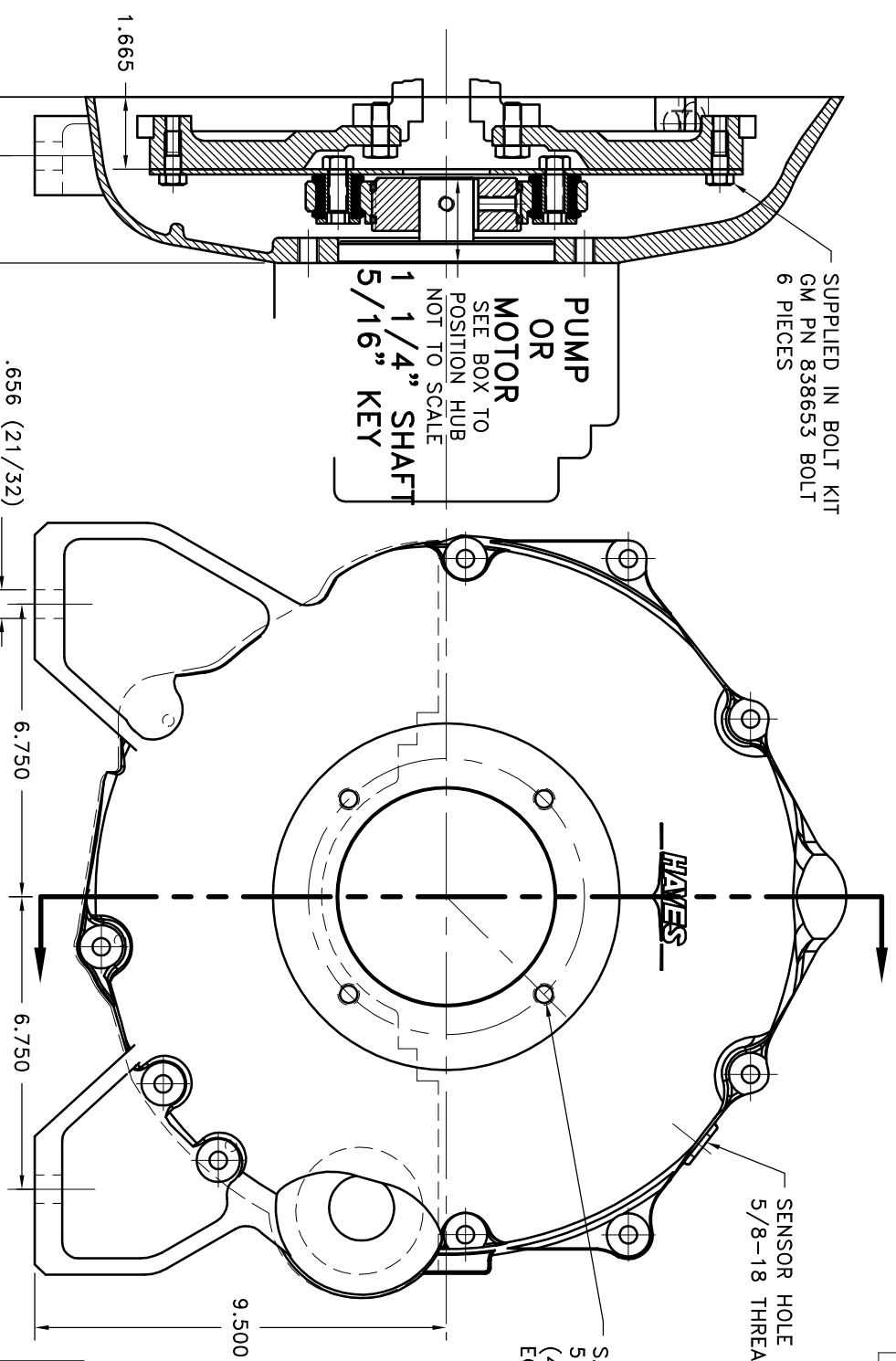

PUMP  
OR  
MOTOR  
SEE BOX TO  
POSITION HUB  
NOT TO SCALE  
1 1/4" SHAFT  
5/16" KEY

NOTE: REMOVE HUB FROM ASSY, PRESET HUB ON SHAFT & REASSEMBLE USING NUT & BOLT GRADE LOC-TITE ON SET SCREWS. SHAFT SHOULD HAVE A MINIMUM OF 3/4" OF ENGAGEMENT IF NOT CONTACT FACTORY FOR THIS RECOMMENDATIONS. TO GET HUB PRESET USE THIS EQUATION:  
EXAMPLE:  
1.97 - SHAFT LENGTH = HUB PRESET  
IF YOUR ANSWER IS (+) SHAFT IS INSIDE OF HUB, IF YOUR ANSWER IS (-) SHAFT STICKS OUT OF HUB. (SEE BOXES)

NOTE: THIS STEP IS IMPORTANT TO ENSURE FULL SPLINE ENGAGEMENT.

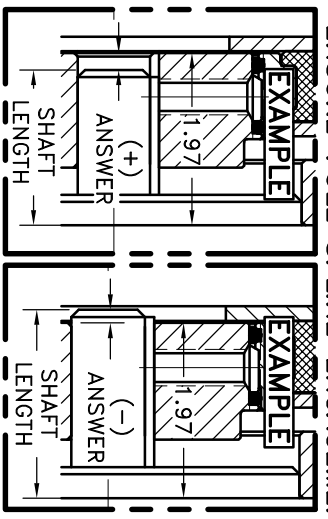

**GM 5.7 LITRE**

**COUPLING ASSY  
128222**

QTY.	DESCRIPTION	PART NUMBER	DET.
1	FLYWHEEL PLATE	126151-07	1
1	COUPLING HUB	128225	2
1	EXT SPL HUB	125663-43	3
10	NEOPRENE INSERT	H62500	4
10	THREADED BUSHING	123727	5
2	O-RING	568-236	7
1	SSSCP	3/8-16 x 5/8"	9
1	SSSCP	3/8-16 x 3/4"	8
1	SSSCP	3/8-16 x 5/8"	10
1	SSSCP	3/8-16 x 3/4"	11
1	SSSCP	3/8-16 x 5/8"	12
1	SSSCP	3/8-16 x 3/4"	13

**SYMBOLS**

- FINISH
- UNLESS OTHERWISE SPECIFIED -
- REWORK FIRST TIME
- BREAK ALL SHARP CORNERS .010 TO .020
- STAMP OR MARK DRAWING NO.

**GM HOUSING & FLYWHEEL COUPLING ASSY**

**HAYES** MANUFACTURING INC. ®

DRAWN BY: DATE: 04-06-06  
CHECKED BY: SCALE: 890026  
SHEET OF REV.