

REV	DATE	CHANGE DESCRIPTION	MOD.BY	CK1	CK2
E	01/02/2006	CHANGED FLYWHEEL PLATE #	ZS	RJH	HM

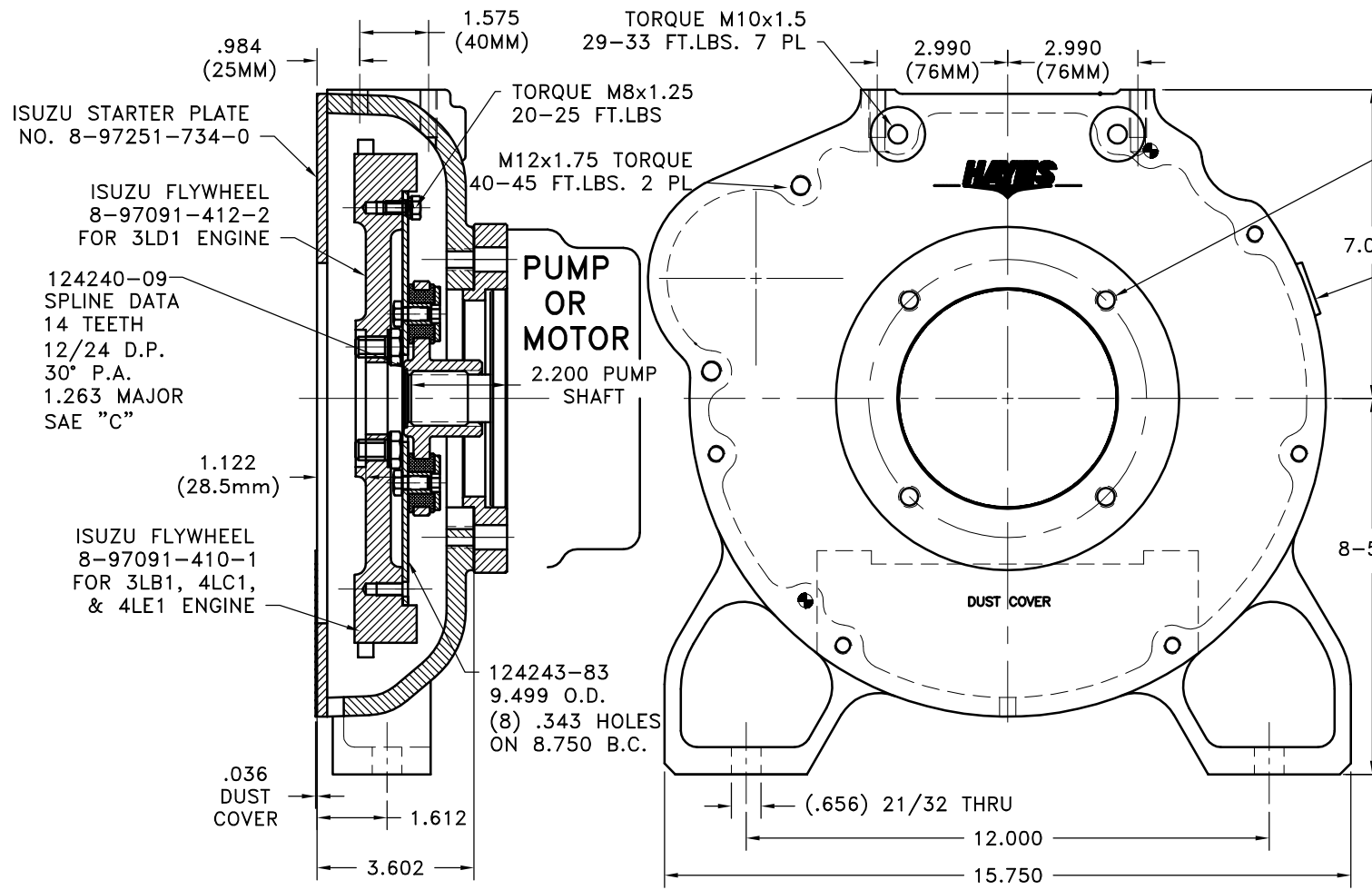

- NOTE:**
- HOUSING FOR ISUZU L-SERIES ENGINES USE FLYWHEEL NO. 8-97091-412-2 FOR 3LD1 ENGINES AND FLYWHEEL NO. 8-97091-410-1 FOR 3LB1, 4LC1, & 4LE1 ENGINES.
 - USE FURNISHED COUPLING GREASE ON BOTH EXTERNAL & INTERNAL SPLINE.

THIS DRAWING IS THE PROPERTY OF HAYES MFG. INC. AND IS LOANED SUBJECT TO THE CONDITION THAT IT SHALL NOT BE REPRODUCED, COPIED, LOANED OR OTHERWISE DISPOSED OF, DIRECTLY OR INDIRECTLY. IT SHALL BE USED AS A MEANS OF REFERENCE TO WORK FURNISHED BY THIS COMPANY ONLY AND IS NOT TO BE SUBMITTED TO OUTSIDE PARTIES FOR EXAMINATION WITHOUT OUR CONSENT.

FLYWHEEL COUPLING ASS'Y 125514

UP TO 50 HP

QTY.	PART NUMBER	DESCRIPTION
1	125253-02	SPACER PLATE
1	902003	BOLT KIT
1	902004	DUST COVER
2	8 PURCHASE	M8x16mm DOWEL
1	902001-03	HOUSING
1	7 801912	GREASE
1	6 HP-1312-S-62	HUBBARD PLUG
8	5 HX100	5/16-24 x 5/8" HHB
8	4 123729-01	THREADED BUSHING
8	3 H52500	NEOPRENE INSERT
1	2 124240-09	COUP HUB [14T12/24\3.875]
1	1 124243-83	FLYWHEEL PLATE [7.5\3.875]

SYMBOLS	DET.	PART NUMBER	DESCRIPTION	QTY.
FLATNESS STRAIGHTNESS ANGULARITY SQUARENESS PARALLELISM CONCENTRICITY TRUE POSITION ROUNDNESS CIRCULAR RUN OUT TOTAL RUN OUT CYLINDRICITY FINISH	DO NOT SCALE DRAWING TOLERANCES UNLESS OTHERWISE SPECIFIED 125 MAXIMUM ANGLE ±1/2° FRACTION ±1/32 DECIMAL .00 ±.01 .000 ±.005 .0000 ±.0005			
- UNLESS OTHERWISE SPECIFIED - REMOVE FIRST THREAD ON ALL TAPPED HOLES BREAK ALL SHARP CORNERS .010 TO .020 STAMP OR MARK DRAWING NO.		DRAWN BY HAVEMAN	DATE 8-9-99	DRAWING NO. 902019 SHEET OF REV.