

REV	DATE	CHANGE DESCRIPTION	MOD.BY	CK1	CK2

**SPECIAL FOR D902**

- NOTES:**
1. HOUSING FOR KUBOTA ENGINES D902
  2. USE FURNISHED COUPLING GREASE ON BOTH MALE AND FEMALE SPLINE.

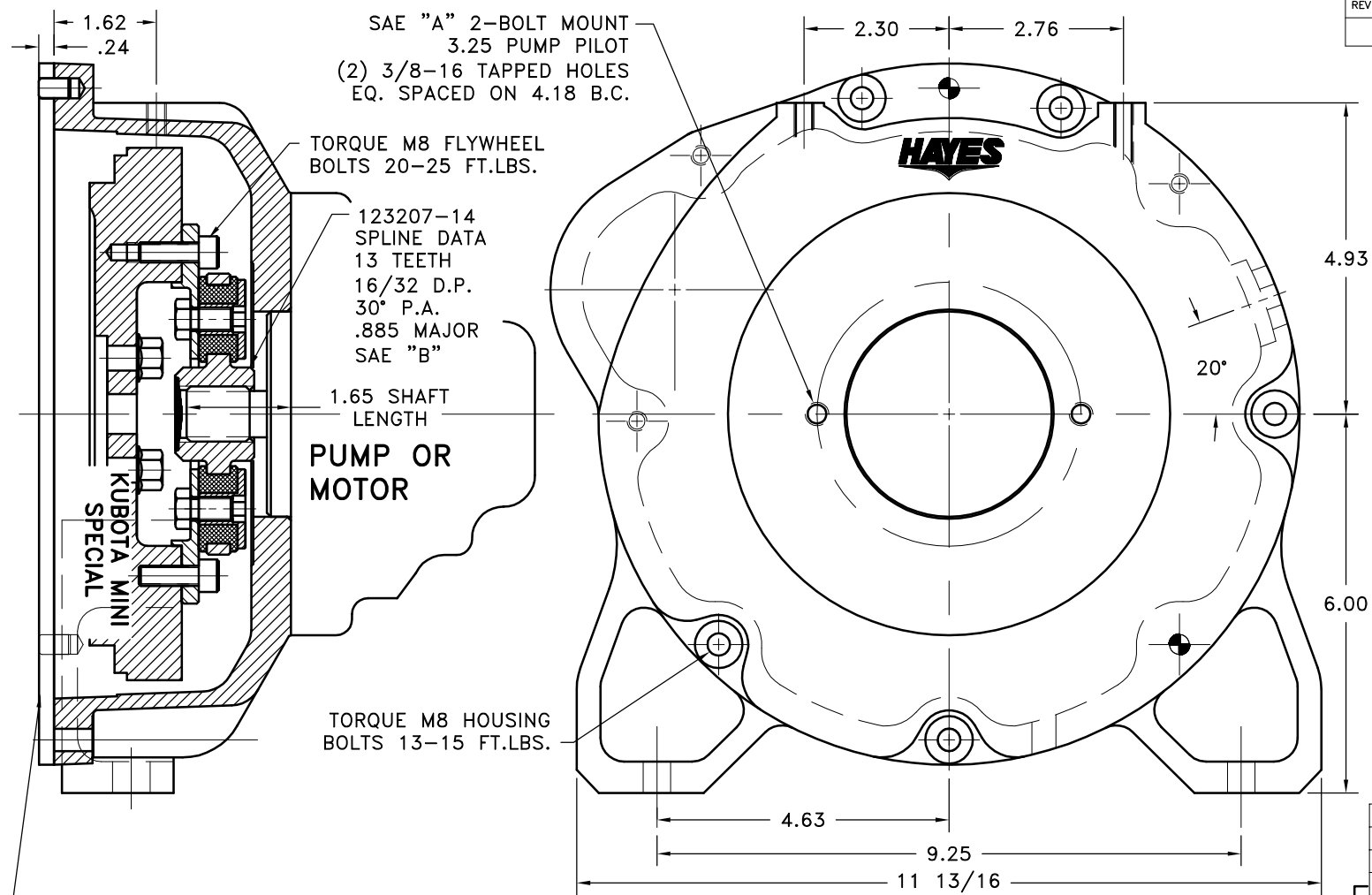

10	930112	BOLT KIT	1
9	PURCHASE	5/16 DIA x 1/2 DOWEL PIN	2
8	930114-01	HOUSING	1
7	801912	GREASE	1
6	HP-1125-S-32	HUBBARD PLUG	1
5	HX100	5/16-24x5/8 HHB	3
4	123729-01	THREADED BUSHING	3
3	H52500	NEOPRENE INSERT	3
2	123207-14	COUPLING HUB	1
1	127581	FLYWHEEL PLATE	1

**COUPLING ASS'Y  
#127582**

SYMBOLS	DET.	PART NUMBER	DESCRIPTION	QTY.
▨ FLATNESS — STRAIGHTNESS ∠ ANGULARITY ⊥ SQUARENESS ∥ PARALLELISM ⊙ CONCENTRICITY ⊕ TRUE POSITION ○ ROUNDNESS ⊖ CIRCULAR RUN OUT ⊖ TOTAL RUN OUT ⊖ CYLINDRICITY √ FINISH	DO NOT SCALE DRAWING TOLERANCES UNLESS OTHERWISE SPECIFIED 125/ MAXIMUM ANGLE ±1/2° FRACTION ±1/32 DECIMAL .00 ±.01 .000 ±.005 .0000 ±.0005		<b>HAYES</b> MANUFACTURING INC. ® TITLE KUBOTA MINI SERIES HOUSING & FLYWHEEL COUPLING ASSY MATERIAL	
- UNLESS OTHERWISE SPECIFIED - REMOVE FIRST THREAD ON ALL TAPPED HOLES BREAK ALL SHARP CORNERS .010 TO .020 STAMP OR MARK DRAWING NO.		DRAWN BY SIETING	DATE 09-19-06	DRAWING NO. 902517 SHEET OF REV.
		CHECKED BY RJH	SCALE	

THIS DRAWING IS THE PROPERTY OF HAYES MFG. INC. AND IS LOANED SUBJECT TO THE CONDITION THAT IT SHALL NOT BE REPRODUCED, COPIED, LOANED OR OTHERWISE DISPOSED OF, DIRECTLY OR INDIRECTLY. IT SHALL BE USED AS A MEANS OF REFERENCE TO WORK FURNISHED BY THIS COMPANY ONLY AND IS NOT TO BE SUBMITTED TO OUTSIDE PARTIES FOR EXAMINATION WITHOUT OUR CONSENT.