

REV	DATE	CHANGE DESCRIPTION	MOD. BY	CK1	CK2
A1	02/19/2003	ADDED ATTN BOX.	ZS	RJH	HM

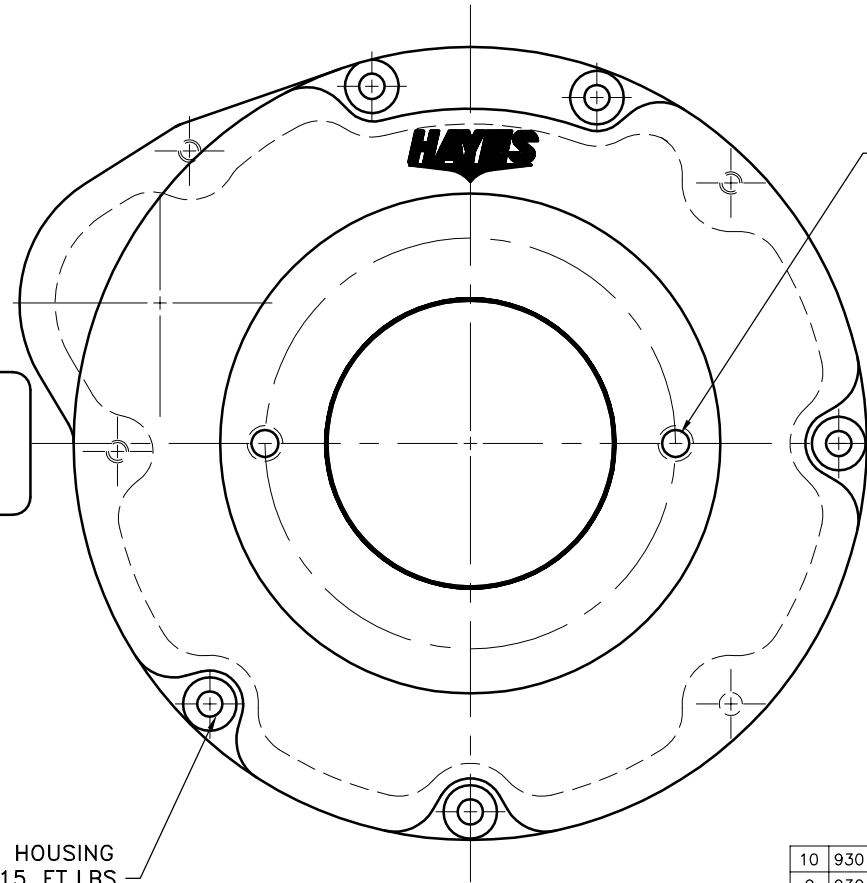
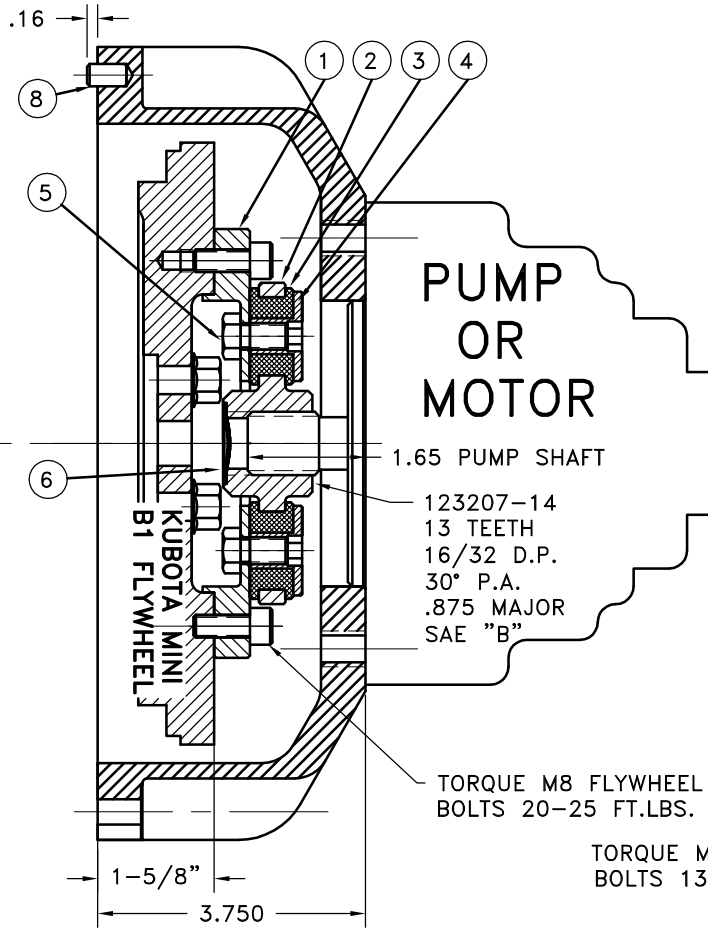

SAE "B" 2-BOLT MOUNT  
4.00 DIA PUMP PILOT  
(2) 1/2-13 TAPPED HOLES  
EQ. SPACED ON 5.75 B.C.

**UP TO 20 HP**

10	930100-02	HOUSING	1
9	930112	BOLT KIT	1
8	PURCHASE	5/16 DIA x 1/2 DOWEL PIN	2
7	801912	GREASE	1
6	HP-1125-S-32	HUBBARD PLUG	1
5	HX100	5/16-24x5/8 H.H.B.	3
4	123729-01	THREADED BUSHING	3
3	H52500	NEOPRENE INSERT	3
2	123207-14	COUPLING HUB	1
1	123394	FLYWHEEL PLATE	1

**COUPLING ASS'Y #124152**

**ASS'Y WORKS WITH  
FLYWHEELS: C-1(16851-25118)  
& C-2(16861-25112)  
STARTER PLATE: E-2(19666-04621)**

**NOTES:**

1. HOUSING FOR KUBOTA ENGINES Z442-B, Z482-B, D662-B, D722-B, WG600-B, WG750-B
2. USE FURNISHED TEXACO 1912 COUPLING GREASE ON BOTH MALE AND FEMALE SPLINE.

THIS DRAWING IS THE PROPERTY OF HAYES MFG. INC. AND IS LOANED SUBJECT TO THE CONDITION THAT IT SHALL NOT BE REPRODUCED, COPIED, LOANED OR OTHERWISE DISPOSED OF, DIRECTLY OR INDIRECTLY. IT SHALL BE USED AS A MEANS OF REFERENCE TO WORK FURNISHED BY THIS COMPANY ONLY AND IS NOT TO BE SUBMITTED TO OUTSIDE PARTIES FOR EXAMINATION WITHOUT OUR CONSENT.

SYMBOLS	DET.	PART NUMBER	DESCRIPTION	QTY.
FLATNESS STRAIGHTNESS ANGULARITY SQUARENESS PARALLELISM CONCENTRICITY TRUE POSITION ROUNDNESS CIRCULAR RUN OUT TOTAL RUN OUT CYLINDRICITY FINISH	DO NOT SCALE DRAWING TOLERANCES UNLESS OTHERWISE SPECIFIED 1/16" MAXIMUM ANGLE ±1/2° FRACTION ±1/32 DECIMAL .00 ±.01 .000 ±.005 .0000 ±.0005			
- UNLESS OTHERWISE SPECIFIED - REMOVE FIRST THREAD ON ALL TAPPED HOLES BREAK ALL SHARP CORNERS .010 TO .020 STAMP OR MARK DRAWING NO.		DRAWN BY HAYEMAN	DATE 2-28-00	DRAWING NO. <b>930101</b> SHEET OF REV.