

REV	DATE	CHANGE DESCRIPTION	MOD.BY	CK1	CK2
C	03/04/2002	ADDED COMPATIBILITY NOTE	ZS	RJH	HM

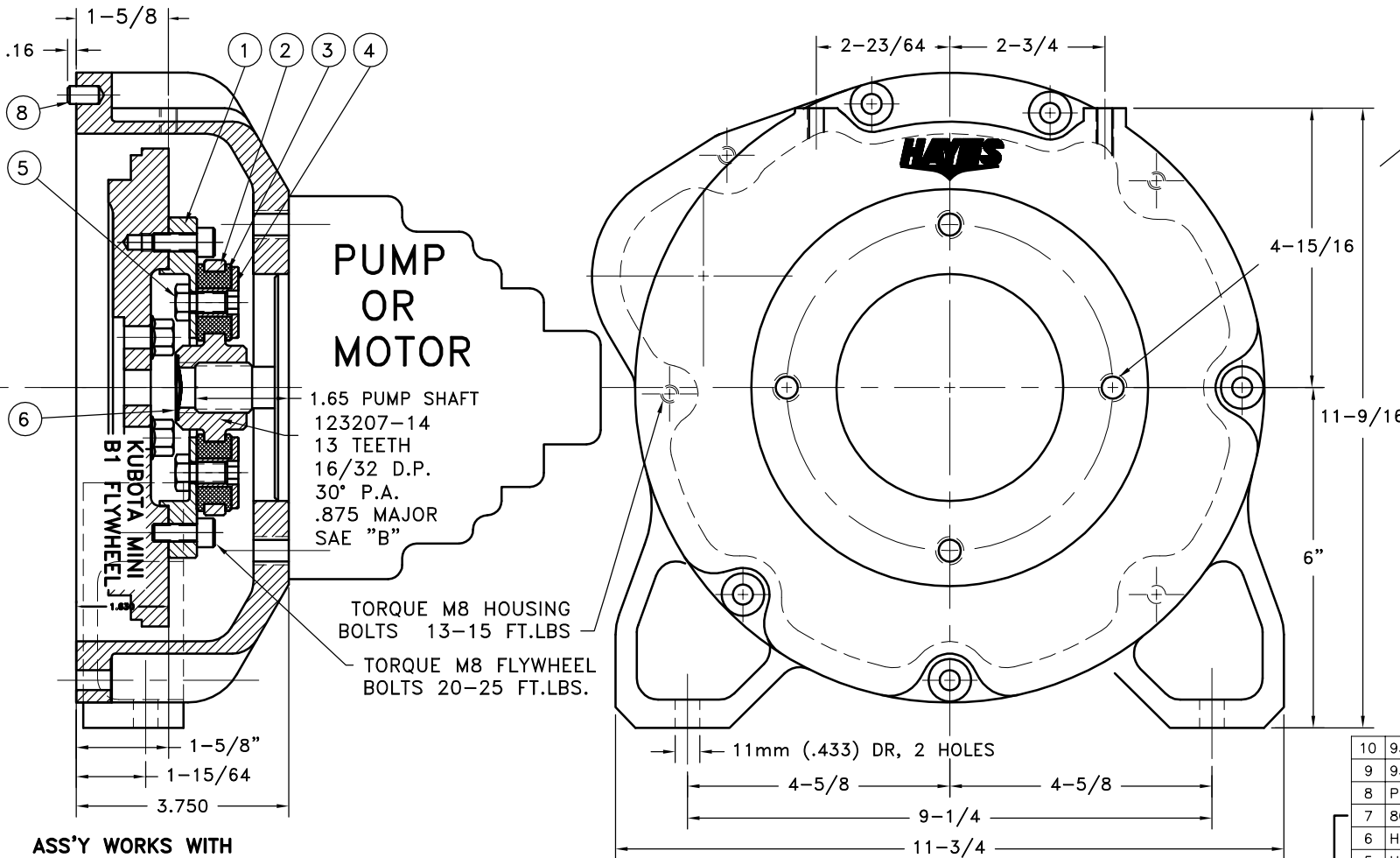

SAE "B" 2-BOLT MOUNT
 4.00 DIA PUMP PILOT
 (4) 1/2-13 TAPPED HOLES
 EQ. SPACED ON 5.75 B.C.

**PUMP
OR
MOTOR**

1.65 PUMP SHAFT
 123207-14
 13 TEETH
 16/32 D.P.
 30° P.A.
 .875 MAJOR
 SAE "B"

TORQUE M8 HOUSING
 BOLTS 13-15 FT.LBS
 TORQUE M8 FLYWHEEL
 BOLTS 20-25 FT.LBS.

UP TO 20 HP

**ASS'Y WORKS WITH
 FLYWHEELS: C-1(16851-25118)
 & C-2(16861-25112)
 STARTER PLATE: E-2(19666-04621)**

NOTES:

- HOUSING FOR KUBOTA ENGINES Z442-B, Z482-B, D662-B, D722-B, WG600-B, WG750-B
- USE FURNISHED COUPLING GREASE ON BOTH MALE AND FEMALE SPLINE.

**COUPLING ASS'Y
 #124152**

10	930114-03	HOUSING	1
9	930112	BOLT KIT	1
8	PURCHASE	5/16 DIA x 1/2 DOWEL PIN	2
7	801912	GREASE	1
6	HP-1125-S-32	HUBBARD PLUG	1
5	HX100	5/16-24x5/8 H.H.B.	3
4	123729-01	THREADED BUSHING	3
3	H52500	NEOPRENE INSERT	3
2	123207-14	COUPLING HUB	1
1	123394	FLYWHEEL PLATE	1

SYMBOLS	DET.	PART NUMBER	DESCRIPTION	QTY.
▭ FLATNESS ▭ STRAIGHTNESS ▭ ANGULARITY ▭ SQUARENESS ▭ PARALLELISM ▭ CONCENTRICITY ⊕ TRUE POSITION ○ ROUNDNESS ⊙ CIRCULAR RUN OUT ⊙ TOTAL RUN OUT ⊙ CYLINDRICITY ✓ FINISH	DO NOT SCALE DRAWING TOLERANCES UNLESS OTHERWISE SPECIFIED MAXIMUM ANGLE ±1/2° FRACTION ±1/32 DECIMAL .00 ±.01 .000 ±.005 .0000 ±.0005		HAYES MANUFACTURING INC. ® TITLE KUBOTA MINI SERIES HOUSING & FLYWHEEL COUPLING ASS'Y MATERIAL	
- UNLESS OTHERWISE SPECIFIED - REMOVE FIRST THREAD ON ALL TAPPED HOLES BREAK ALL SHARP CORNERS .010 TO .020 STAMP OR MARK DRAWING NO.		DRAWN BY HAVEMAN	DATE 3-21-00	DRAWING NO. 930145 SHEET OF REV.

THIS DRAWING IS THE PROPERTY OF HAYES MFG. INC. AND IS LOANED SUBJECT TO THE CONDITION THAT IT SHALL NOT BE REPRODUCED, COPIED, LOANED OR OTHERWISE DISPOSED OF, DIRECTLY OR INDIRECTLY. IT SHALL BE USED AS A MEANS OF REFERENCE TO WORK FURNISHED BY THIS COMPANY ONLY AND IS NOT TO BE SUBMITTED TO OUTSIDE PARTIES FOR EXAMINATION WITHOUT OUR CONSENT.