

REV	DATE	CHANGE DESCRIPTION	MOD. BY	CK1	CK2

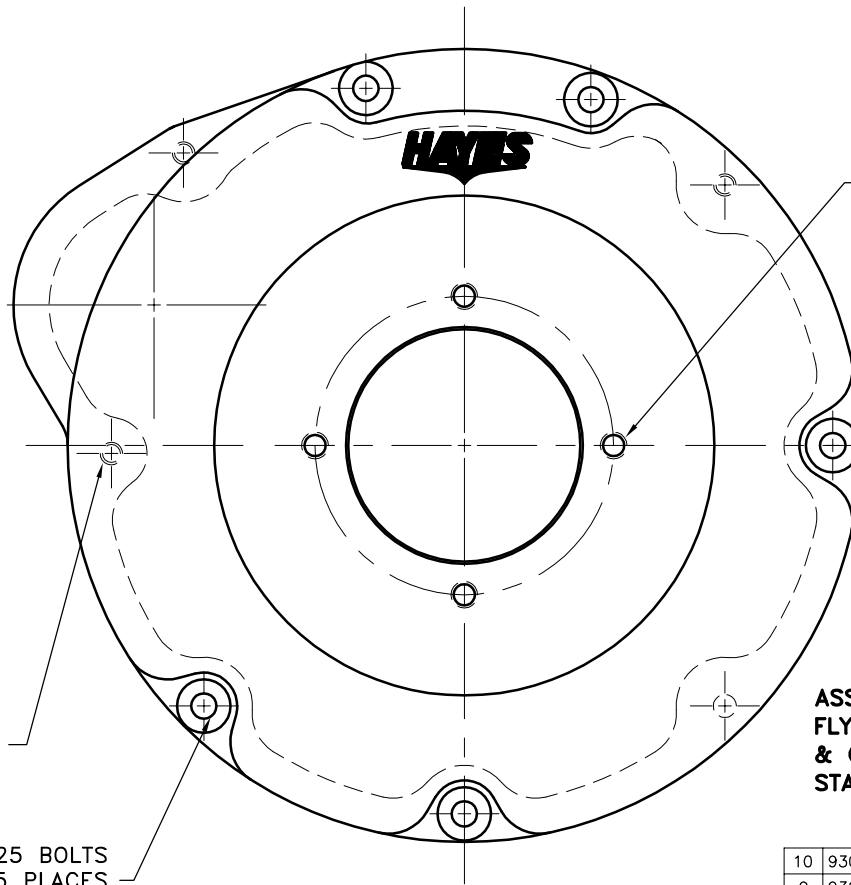
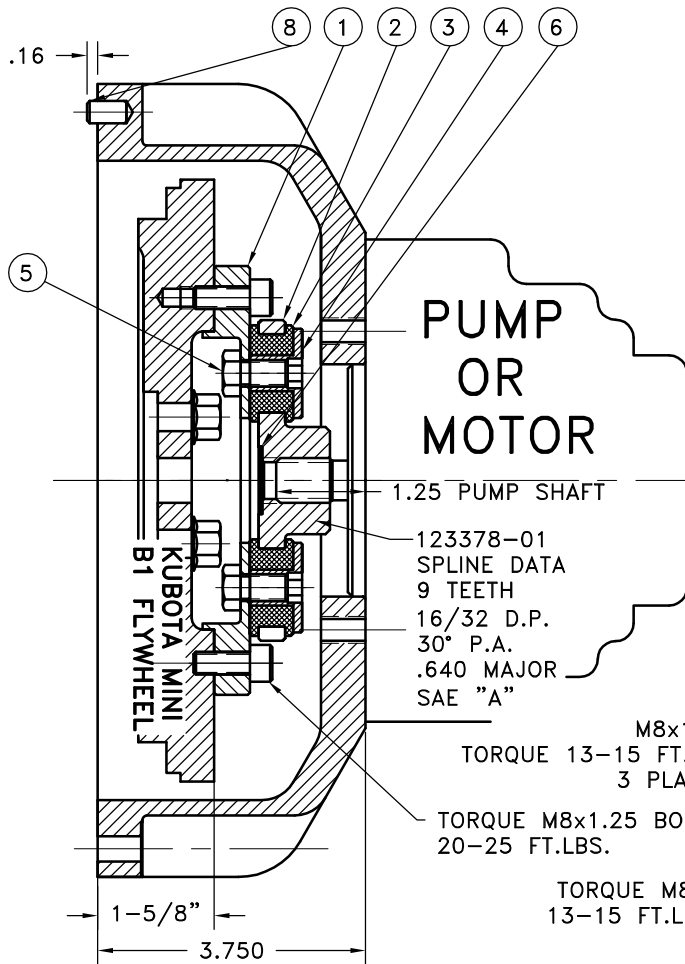

SAE "A" 2-BOLT MOUNT
HORIZONTAL & VERTICAL
3.25 PUMP PILOT
(4) 3/8-16 TAPPED HOLES
EQ. SPACED ON 4.18 B.C.

**ASS'Y WORKS WITH
FLYWHEELS: C-1(16851-25118)
& C-2(16861-25112)
STARTER PLATE: E-2(19666-04621)
UP TO 20 HP**

NO.	PART NUMBER	DESCRIPTION	QTY.
10	930100-09	HOUSING	1
9	930112	BOLT KIT	1
8	PURCHASE	5/16 DIA x 1/2 DOWEL PIN	2
7	801912	GREASE	1
6	HP-937-S-32	HUBBARD PLUG	1
5	HX100	5/16-24x5/8 H.H.B.	3
4	123729-01	THREADED BUSHING	3
3	H52500	NEOPRENE INSERT	3
2	123378-01	COUPLING HUB	1
1	123394	FLYWHEEL PLATE	1

**COUPLING ASS'Y
#124138**

NOTES:

- HOUSING FOR KUBOTA ENGINES Z442-B, Z482-B, D662-B, D722-B, WG600-B, WG750-B
- USE FURNISHED TEXACO 1912 COUPLING GREASE ON BOTH MALE AND FEMALE SPLINE.

THIS DRAWING IS THE PROPERTY OF HAYES MFG. INC. AND IS LOANED SUBJECT TO THE CONDITION THAT IT SHALL NOT BE REPRODUCED, COPIED, LOANED OR OTHERWISE DISPOSED OF, DIRECTLY OR INDIRECTLY. IT SHALL BE USED AS A MEANS OF REFERENCE TO WORK FURNISHED BY THIS COMPANY ONLY AND IS NOT TO BE SUBMITTED TO OUTSIDE PARTIES FOR EXAMINATION WITHOUT OUR CONSENT.

SYMBOLS	DET.	PART NUMBER	DESCRIPTION	QTY.
▨ FLATNESS — STRAIGHTNESS ∠ ANGULARITY ⊥ SQUARENESS ∥ PARALLELISM ⊙ CONCENTRICITY ⊕ TRUE POSITION ○ ROUNDNESS ⊘ CIRCULAR RUN OUT ⊖ TOTAL RUN OUT ∅ CYLINDRICITY ✓ FINISH	DO NOT SCALE DRAWING TOLERANCES UNLESS OTHERWISE SPECIFIED 1/16" MAXIMUM ANGLE ±1/2° FRACTION ±1/32 DECIMAL .00 ±.01 .000 ±.005 .0000 ±.0005			
- UNLESS OTHERWISE SPECIFIED - REMOVE FIRST THREAD ON ALL TAPPED HOLES BREAK ALL SHARP CORNERS .010 TO .020 STAMP OR MARK DRAWING NO.		DRAWN BY SIETING CHECKED BY RJH	DATE 04-29-03 SCALE	DRAWING NO. 930180 SHEET OF REV.