

REV	DATE	CHANGE DESCRIPTION	MOD.BY	CK1	CK2
A2	07/25/2006	FIXED DOWEL DEPTH NOTES.	ZS		

124118-01  
8.499 DIA  
(6) .406 DIA HOLES  
EQ. SPACED ON 7.283 B.C.

123207-02  
SPLINE DATA  
13 TEETH  
16/32 D.P.  
30° P.A.  
.885 MAJOR  
SAE "B"

S.A.E. A PUMP MOUNT  
3.25" PILOT  
(4) 3/8-16 TAPPED HOLES  
EQ. SPACED ON A 4.19 B.C.

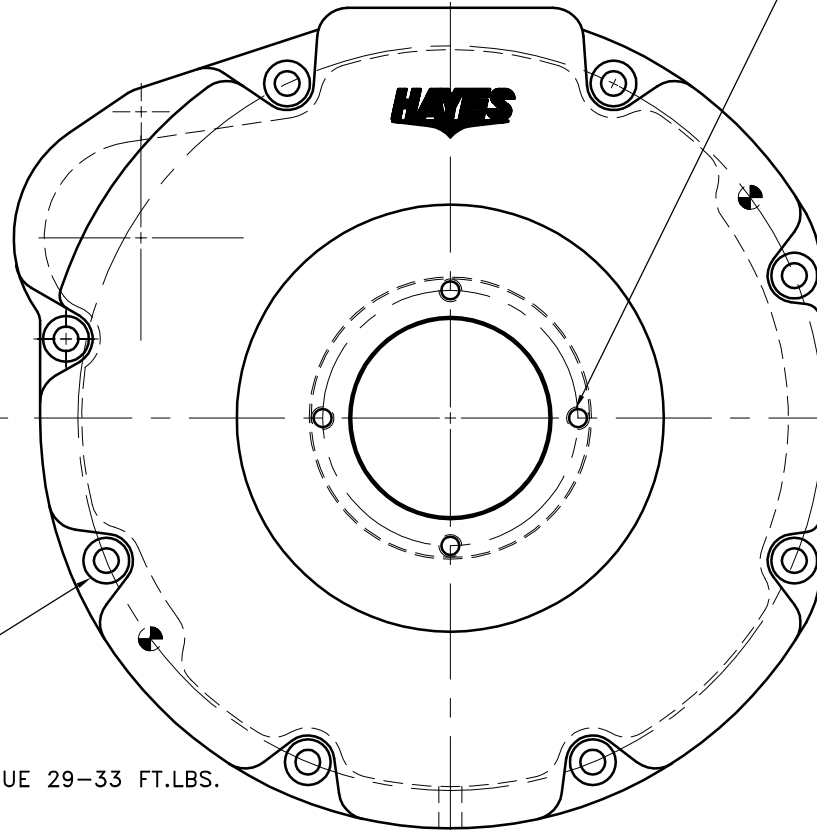
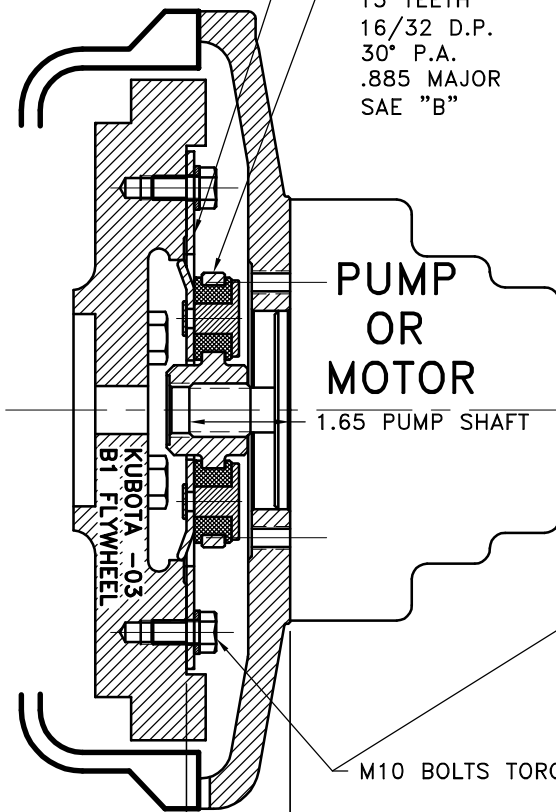

NOTE: INSTALL 2 DOWEL PINS

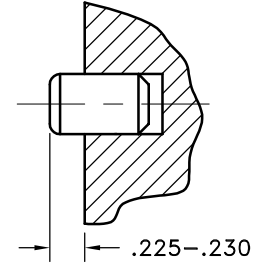

M10 BOLTS TORQUE 29-33 FT.LBS.

.197  
1.500  
1.696

## KUBOTA -03 SERIES

COUPLING ASS'Y #124099

9	933113	BOLT KIT	1
8	PURCHASE	M10 x 20mm DOWEL PINS	2
7	933023-10	HOUSING	1
6	801912	GREASE	1
5	HP-1125-S-32	HUBBARD PLUG	1
4	123206-01	STEEL RIVET	6
3	H52500	NEOPRENE INSERT	6
2	123207-02	COUPLING HUB [13 16/32\3.000]	1
1	124118-01	FLYWHEEL PLATE [SPEC.\3.000]	1

ASS'Y WORKS WITH  
FLYWHEELS: C-1(16414-25111) &  
C-4(19629-25113)  
HOUSINGS: D-9(19004-04611) &  
D-8(19077-04611)

NOTE:

- HOUSING FOR KUBOTA ENGINES D1403-B, D1703-B, V1903-B, AND V2203-B.
- USE FURNISHED COUPLING GREASE ON BOTH MALE AND FEMALE SPLINE.
- DOWEL PIN MUST BE PRESSED IN SO THERE IS ONLY .230-.225 OF DOWEL STICKING OUT OF HOUSING.

THIS DRAWING IS THE PROPERTY OF HAYES MFG. INC. AND IS LOANED SUBJECT TO THE CONDITION THAT IT SHALL NOT BE REPRODUCED, COPIED, LOANED OR OTHERWISE DISPOSED OF, DIRECTLY OR INDIRECTLY. IT SHALL BE USED AS A MEANS OF REFERENCE TO WORK FURNISHED BY THIS COMPANY ONLY AND IS NOT TO BE SUBMITTED TO OUTSIDE PARTIES FOR EXAMINATION WITHOUT OUR CONSENT.

SYMBOLS	DET.	PART NUMBER	DESCRIPTION	QTY.
FLATNESS STRAIGHTNESS ANGULARITY SQUARENESS PARALLELISM CONCENTRICITY TRUE POSITION ROUNDNESS CIRCULAR RUN OUT TOTAL RUN OUT CYLINDRICITY FINISH	DO NOT SCALE DRAWING TOLERANCES UNLESS OTHERWISE SPECIFIED 125 MAXIMUM ANGLE ±1/2° FRACTION ±1/32 DECIMAL .00 ±.01 .000 ±.005 .0000 ±.0005		 TITLE KUBOTA -03 SERIES HOUSING & FLYWHEEL COUPLING ASSY MATERIAL	
- UNLESS OTHERWISE SPECIFIED - REMOVE FIRST THREAD ON ALL TAPPED HOLES BREAK ALL SHARP CORNERS .010 TO .020 STAMP OR MARK DRAWING NO.	DRAWN BY SIETING CHECKED BY RJH	DATE 04-04-03 SCALE	DRAWING NO. 933129 SHEET OF REV.	