

REV	DATE	CHANGE DESCRIPTION	MOD. BY	CK1	CK2
A2	08/29/2006	ADDED ATTN BOX.	ZS	RJH	HM

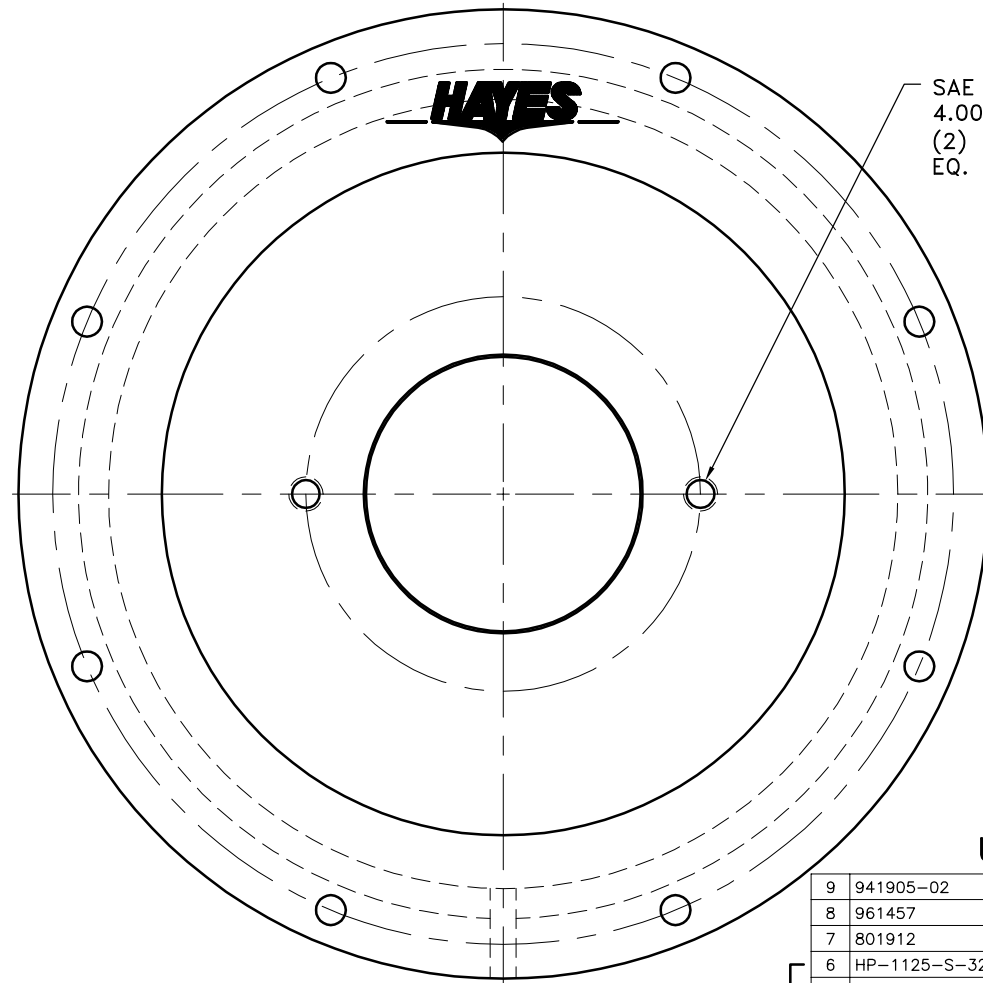
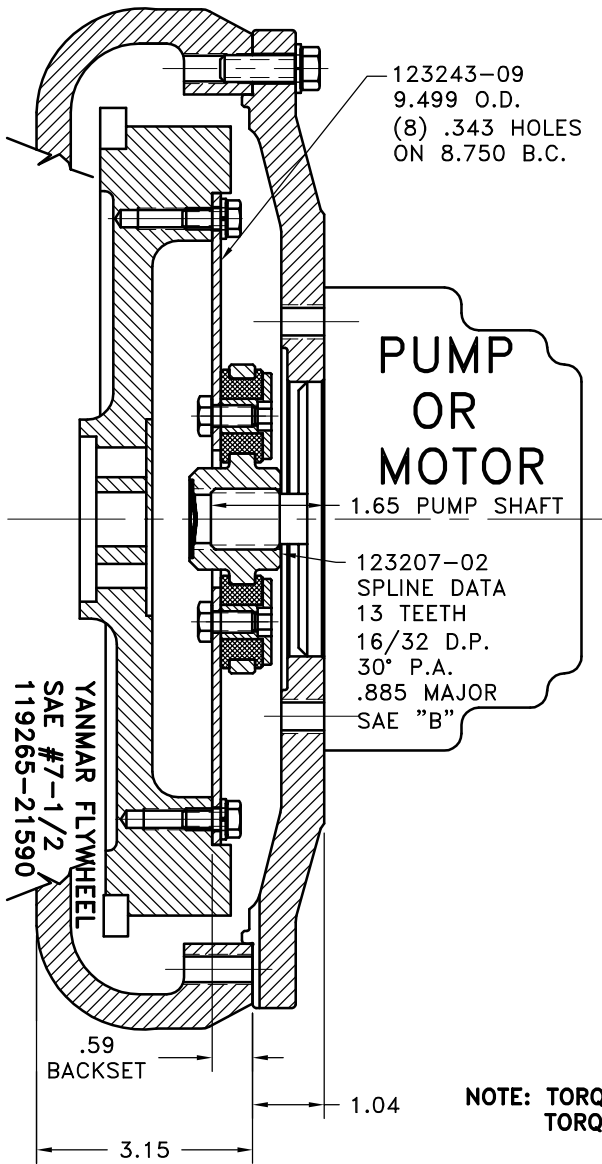

**NOTE: TORQUE ALL M10 BOLTS 29-33 FT.LBS.
TORQUE ALL M8 BOLTS 20-25 FT.LBS.**

**NOTE: FITS YANMAR ENGINE
NO.s 3TNE84VM, 3TNE84TVM,
SEMI SAE #5 HOUSING**

**COUPLING ASS'Y
#123277**

UP TO 50 HP

QTY.	DESCRIPTION	PART NUMBER	DET.
1	FLYWHEEL PLATE [7.5\3.000]	123243-09	1
1	COUPLING HUB [13 16/32\3.000]	123207-02	2
6	NEOPRENE INSERTS	H52500	3
6	THREADED BUSHING	123729-01	4
1	5/16-24 x 5/8" HHB	HX100	5
6	HUBBARD PLUG	HP-1125-S-32	6
1	GREASE	801912	7
1	BOLT KIT	961457	8
1	HOUSING [5]	941905-02	9

SYMBOLS	DET.	PART NUMBER	DESCRIPTION	QTY.	
▨ FLATNESS — STRAIGHTNESS ∠ ANGULARITY ⊥ SQUARENESS ∥ PARALLELISM ⊙ CONCENTRICITY ⊕ TRUE POSITION ○ ROUNDNESS Ⓞ CIRCULAR RUN OUT Ⓣ TOTAL RUN OUT Ⓢ CYLINDRICITY √ FINISH	DO NOT SCALE DRAWING TOLERANCES UNLESS OTHERWISE SPECIFIED 125 MAXIMUM ANGLE ±1/2° FRACTION ±1/32 DECIMAL .00 ±.01 .000 ±.005 .0000 ±.0005				
- UNLESS OTHERWISE SPECIFIED - REMOVE FIRST THREAD ON ALL TAPPED HOLES BREAK ALL SHARP CORNERS .010 TO .020 STAMP OR MARK DRAWING NO.			TITLE YANMAR 3TNE HOUSING & FLYWHEEL COUPLING ASSY MATERIAL	DRAWN BY MAYCROFT CHECKED BY RJH DATE 07-31-01 SCALE	DRAWING NO. 941902 SHEET OF 1 OF 1

THIS DRAWING IS THE PROPERTY OF HAYES MFG. INC. AND IS LOANED SUBJECT TO THE CONDITION THAT IT SHALL NOT BE REPRODUCED, COPIED, LOANED OR OTHERWISE DISPOSED OF, DIRECTLY OR INDIRECTLY. IT SHALL BE USED AS A MEANS OF REFERENCE TO WORK FURNISHED BY THIS COMPANY ONLY AND IS NOT TO BE SUBMITTED TO OUTSIDE PARTIES FOR EXAMINATION WITHOUT OUR CONSENT.