

| REV | DATE | CHANGE DESCRIPTION | MOD. BY | CK1 | CK2 |
|-----|------|--------------------|---------|-----|-----|
| | | | | | |

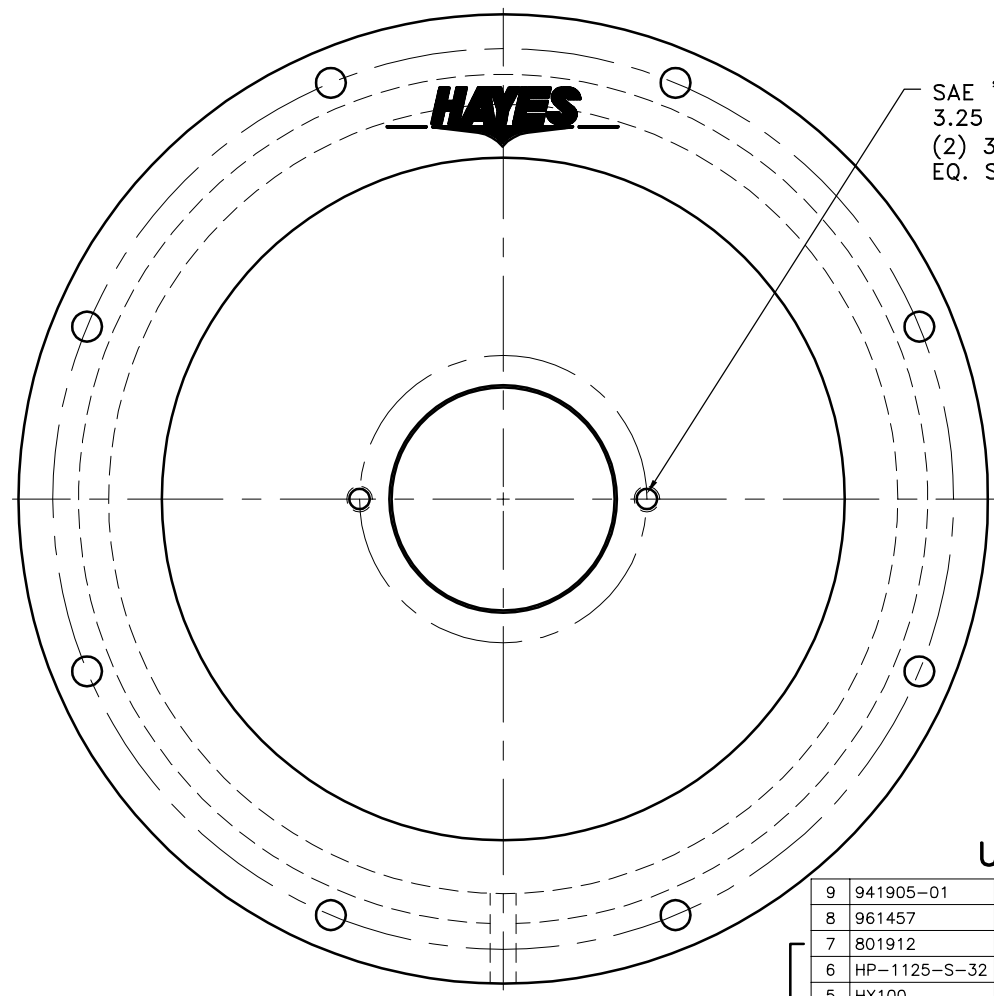
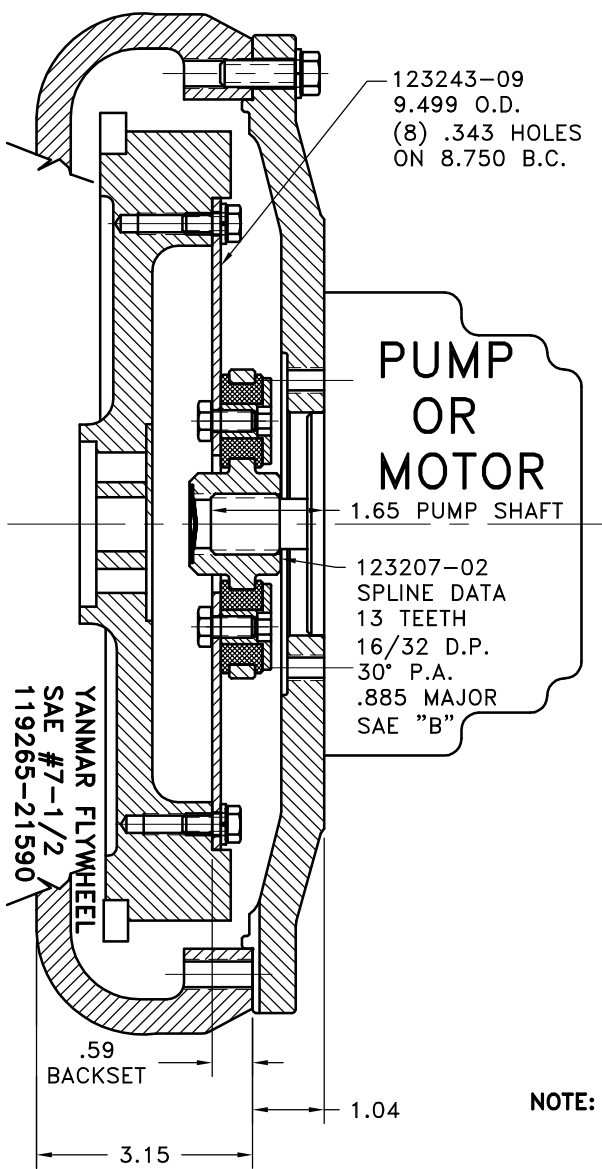

**COUPLING ASS'Y
123957**

UP TO 50 HP

**NOTE: TORQUE ALL M10 BOLTS 29-33 FT.LBS.
TORQUE ALL M8 BOLTS 20-25 FT.LBS.**

**NOTE: FITS YANMAR ENGINE
NO.s 3TNE84VM, 3TNE84TVM,
SEMI SAE #5 HOUSING**

| REV | PART NUMBER | DESCRIPTION | QTY. |
|-----|--------------|----------------------------|------|
| 9 | 941905-01 | HOUSING [5/A 2B] | 1 |
| 8 | 961457 | BOLT KIT | 1 |
| 7 | 801912 | GREASE | 1 |
| 6 | HP-1125-S-32 | HUBBARD PLUG | 1 |
| 5 | HX100 | 5/16-24 x 5/8" HHB | 6 |
| 4 | 123729-01 | THREADED BUSHING | 6 |
| 3 | H52500 | NEOPRENE INSERT | 6 |
| 2 | 123207-02 | COUP HUB [13 16/32\3.000] | 1 |
| 1 | 123243-09 | FLYWHEEL PLATE [7.5\3.000] | 1 |

THIS DRAWING IS THE PROPERTY OF HAYES MFG. INC. AND IS LOANED SUBJECT TO THE CONDITION THAT IT SHALL NOT BE REPRODUCED, COPIED, LOANED OR OTHERWISE DISPOSED OF, DIRECTLY OR INDIRECTLY. IT SHALL BE USED AS A MEANS OF REFERENCE TO WORK FURNISHED BY THIS COMPANY ONLY AND IS NOT TO BE SUBMITTED TO OUTSIDE PARTIES FOR EXAMINATION WITHOUT OUR CONSENT.

| SYMBOLS | DET. | PART NUMBER | DESCRIPTION | QTY. |
|---|--|---------------------|--|---|
| ▨ FLATNESS — STRAIGHTNESS ∠ ANGULARITY ⊥ SQUARENESS ∥ PARALLELISM ⊙ CONCENTRICITY ⊕ TRUE POSITION ○ ROUNDNESS ⊖ CIRCULAR RUN OUT ⊖ TOTAL RUN OUT ⊖ CYLINDRICITY √ FINISH | DO NOT SCALE DRAWING TOLERANCES UNLESS OTHERWISE SPECIFIED 125 MAXIMUM ANGLE ±1/2° FRACTION ±1/32 DECIMAL .00 ±.01 .000 ±.005 .0000 ±.0005 | | HAYES MANUFACTURING INC. ® TITLE YANMAR 3TNE HOUSING & FLYWHEEL COUPLING ASSY MATERIAL | |
| - UNLESS OTHERWISE SPECIFIED - REMOVE FIRST THREAD ON ALL TAPPED HOLES BREAK ALL SHARP CORNERS .010 TO .020 STAMP OR MARK DRAWING NO. | | DRAWN BY SIETING | DATE 09-07-04 | DRAWING NO. 941950 SHEET OF REV. |