

REV	DATE	CHANGE DESCRIPTION	MOD. BY	CK1	CK2

M10 BOLTS TORQUE 29-33 FT.LBS.

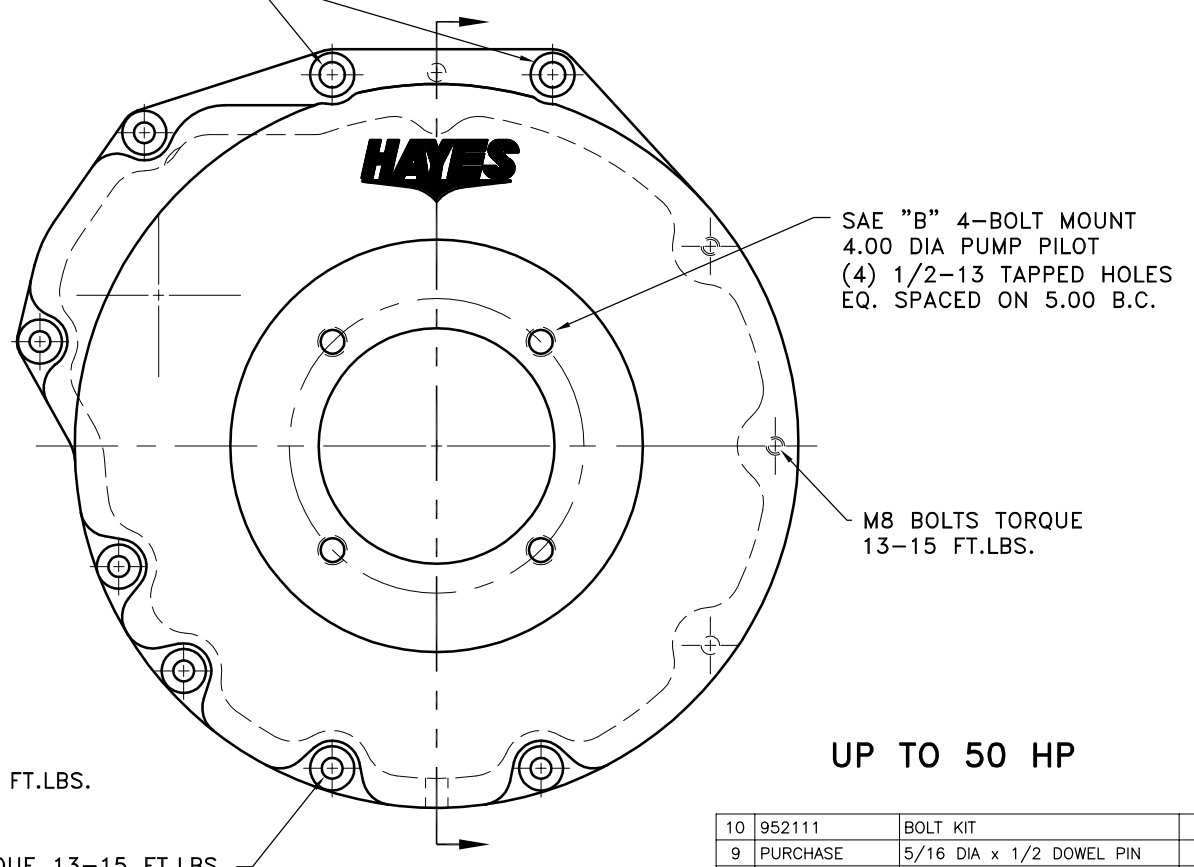
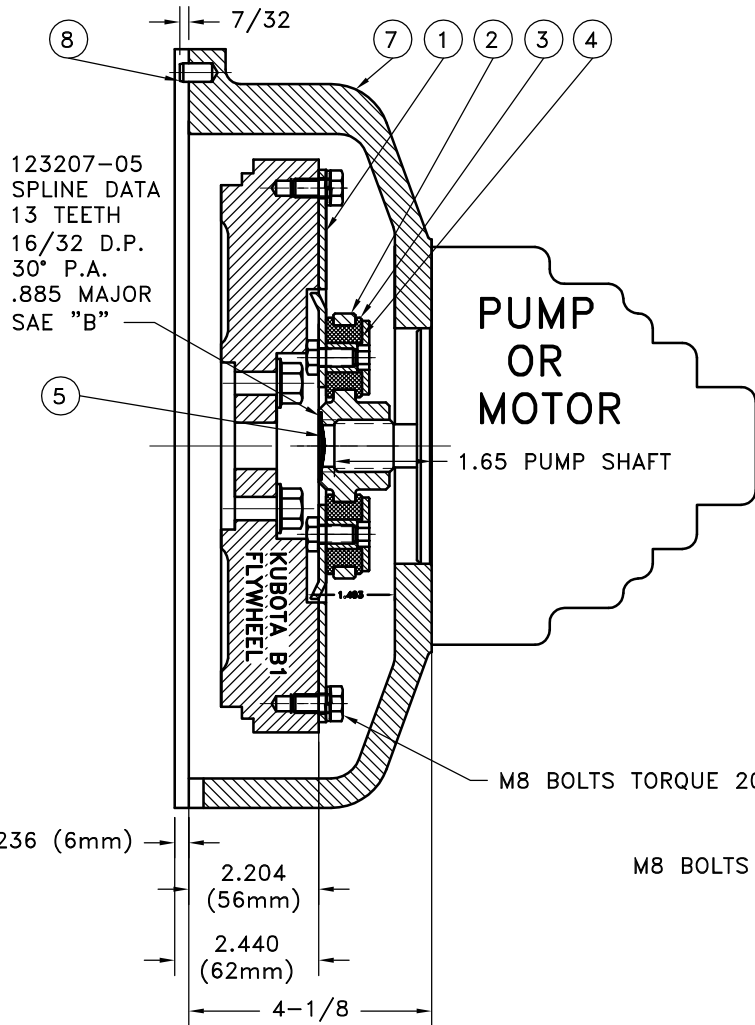

UP TO 50 HP

COUPLING ASS'Y
#126427

10	952111	BOLT KIT	1
9	PURCHASE	5/16 DIA x 1/2 DOWEL PIN	2
8	952066-01	HOUSING	1
7	801912	GREASE	1
6	HP-1125-S-32	HUBBARD PLUG	1
5	HX300	5/16-24x5/8 HHB	6
4	123729-01	THREADED BUSHING	6
3	H52500	NEOPRENE INSERT	6
2	123207-05	COUPLING HUB	1
1	124118-02	FLYWHEEL PLATE	1

NOTES:

1. HOUSING FOR KUBOTA ENGINES D-905, D1005-B, D1105-B, V1205-B, V1305-P, AND V1505-B

2. USE FURNISHED COUPLING GREASE ON BOTH MALE AND FEMALE SPLINE.

THIS DRAWING IS THE PROPERTY OF HAYES MFG. INC. AND IS LOANED SUBJECT TO THE CONDITION THAT IT SHALL NOT BE REPRODUCED, COPIED, LOANED OR OTHERWISE DISPOSED OF, DIRECTLY OR INDIRECTLY. IT SHALL BE USED AS A MEANS OF REFERENCE TO WORK FURNISHED BY THIS COMPANY ONLY AND IS NOT TO BE SUBMITTED TO OUTSIDE PARTIES FOR EXAMINATION WITHOUT OUR CONSENT.

SYMBOLS	DET.	PART NUMBER	DESCRIPTION	QTY.
▨ FLATNESS — STRAIGHTNESS ∟ ANGULARITY ⊥ SQUARENESS ∥ PARALLELISM ⊙ CONCENTRICITY ⊕ TRUE POSITION ○ ROUNDNESS ⊖ CIRCULAR RUN OUT ⊘ TOTAL RUN OUT ∅ CYLINDRICITY ✓ FINISH	DO NOT SCALE DRAWING TOLERANCES UNLESS OTHERWISE SPECIFIED 1/32" MAXIMUM ANGLE ±1/2° FRACTION ±1/32 DECIMAL .00 ±.01 .000 ±.005 .0000 ±.0005			
- UNLESS OTHERWISE SPECIFIED - REMOVE FIRST THREAD ON ALL TAPPED HOLES BREAK ALL SHARP CORNERS .010 TO .020 STAMP OR MARK DRAWING NO.		TITLE KUBOTA-05 HOUSING & FLYWHEEL COUPLING ASS'Y MATERIAL	DRAWN BY SIETING	DATE 08-18-04
		CHECKED BY RJH	DRAWING NO. 952171 SHEET OF REV.	