

REV	DATE	CHANGE DESCRIPTION	MOD.BY	CK1	CK2

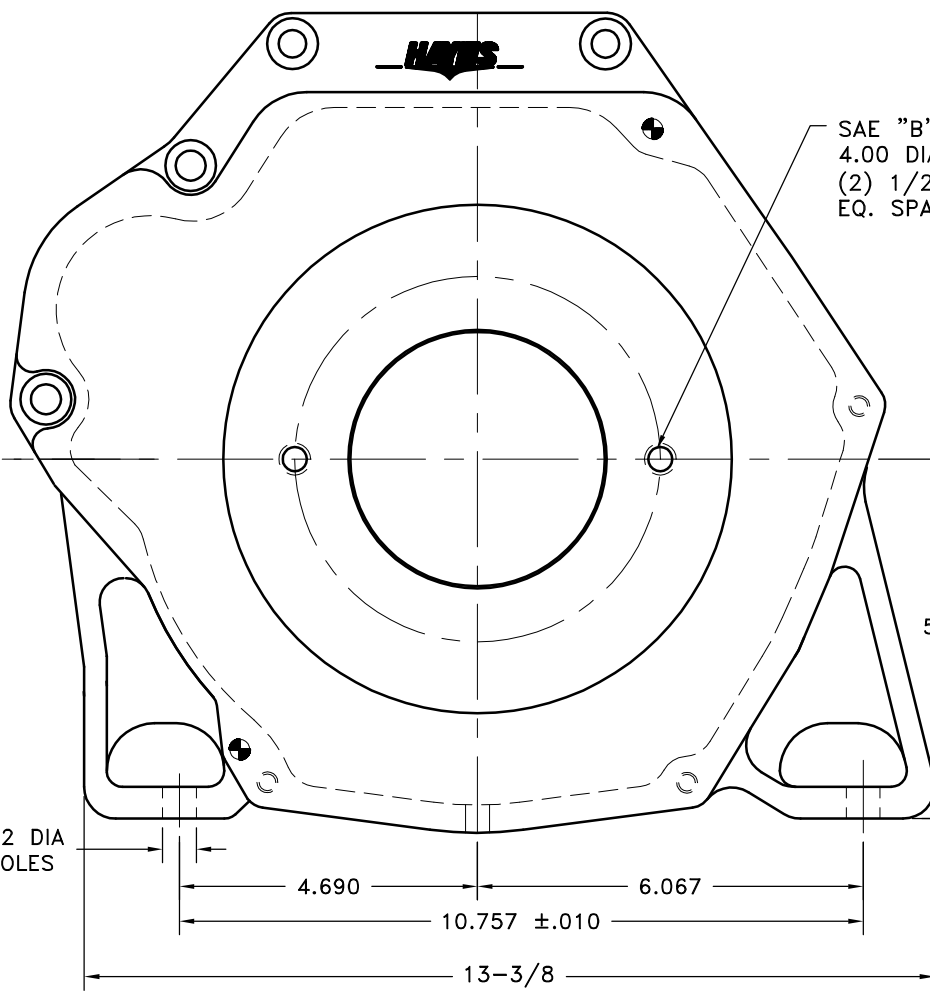
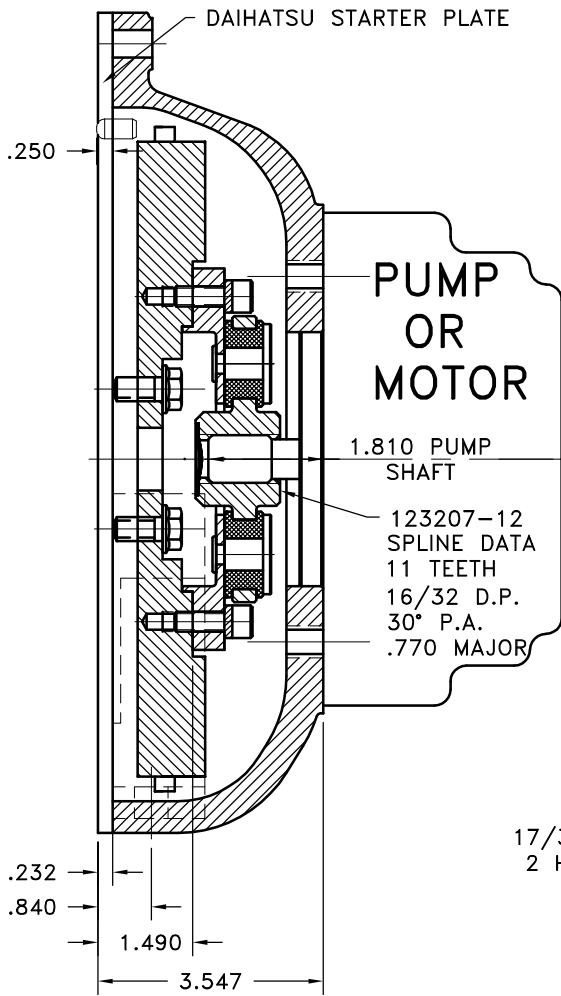

R.F.B.

**NOTE: TORQUE ALL M10 HOUSING BOLTS 29-33 FT.LBS.
TORQUE ALL M8 HOUSING BOLTS 13-15 FT.LBS.
TORQUE ALL M8 FLYWHEEL BOLTS 20-25 FT.LBS.**

**COUPLING ASS'Y
#126419**

UP TO 50 HP

9	959001	BOLT KIT	1
8	PURCHASE	8mmx16mm LG. DOWEL	2
7	959000-02	HOUSING	1
6	801912	GREASE	1
5	HP-1125-S-32	HUBBARD PLUG	1
4	123206-01	STEEL RIVET	6
3	H52500	NEOPRENE INSERT	6
2	123207-12	COUPLING HUB	1
1	123394	FLYWHEEL PLATE	1

NOTES:

1. HOUSING FOR DAIHATSU ENGINES DM700G & DM950G
2. USE FURNISHED TEXACO 1912 COUPLING GREASE ON BOTH INTERNAL & EXTERNAL SPLINES.
3. CAUTION: WHEN INSTALLING PUMP ON ENGINE HOUSING BE CAREFUL BOLTS DO NOT EXTEND PAST INSIDE FACE OF HOUSING AND RUB ON COUPLING ASS'Y.

THIS DRAWING IS THE PROPERTY OF HAYES MFG. INC. AND IS LOANED SUBJECT TO THE CONDITION THAT IT SHALL NOT BE REPRODUCED, COPIED, LOANED OR OTHERWISE DISPOSED OF, DIRECTLY OR INDIRECTLY. IT SHALL BE USED AS A MEANS OF REFERENCE TO WORK FURNISHED BY THIS COMPANY ONLY AND IS NOT TO BE SUBMITTED TO OUTSIDE PARTIES FOR EXAMINATION WITHOUT OUR CONSENT.

SYMBOLS	DET.	PART NUMBER	DESCRIPTION	QTY.
▱ FLATNESS — STRAIGHTNESS ∟ ANGULARITY ⊥ SQUARENESS ∥ PARALLELISM ⊙ CONCENTRICITY ⊕ TRUE POSITION ○ ROUNDNESS ⊖ CIRCULAR RUN OUT ⊖ TOTAL RUN OUT ⊖ CYLINDRICITY √ FINISH	DO NOT SCALE DRAWING TOLERANCES UNLESS OTHERWISE SPECIFIED 125 MAXIMUM ANGLE ±1/2° FRACTION ±1/32 DECIMAL .00 ±.01 .000 ±.005 .0000 ±.0005			
- UNLESS OTHERWISE SPECIFIED - REMOVE FIRST THREAD ON ALL TAPPED HOLES BREAK ALL SHARP CORNERS .010 TO .020 STAMP OR MARK DRAWING NO.		DRAWN BY MAYCROFT CHECKED BY RJH	DATE 08-13-01 SCALE	DRAWING NO. 959016 SHEET OF REV.