

SPECIAL FOR DF972 - WG972

REV	DATE	CHANGE DESCRIPTION	MOD. BY	CK1	CK2
A1	09/19/2006	REMOVED D902 ENGINE	ZS	RJH	HM

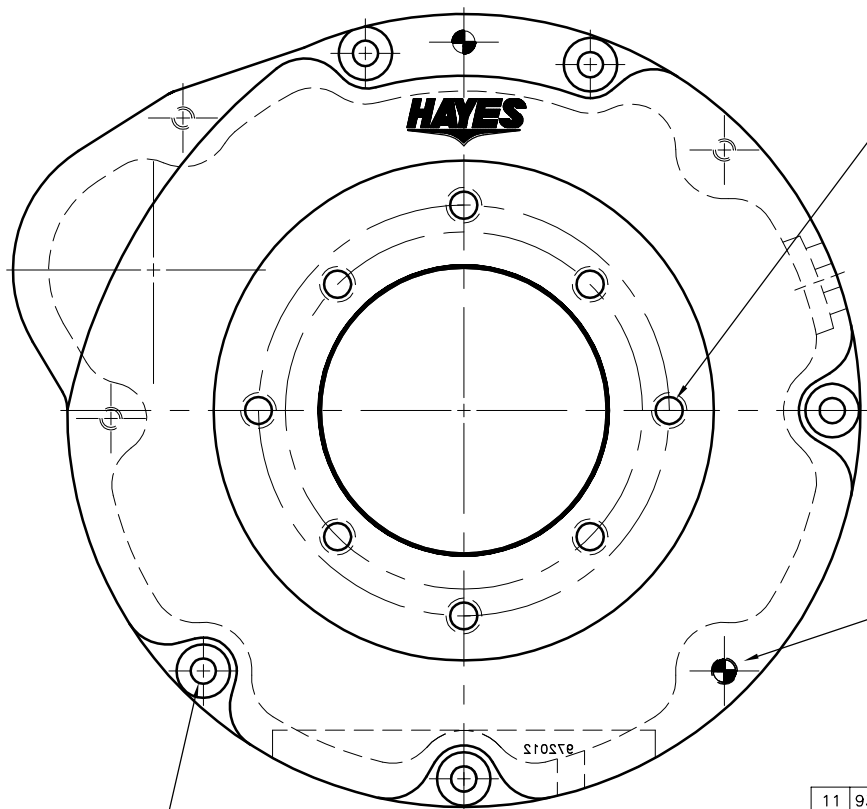
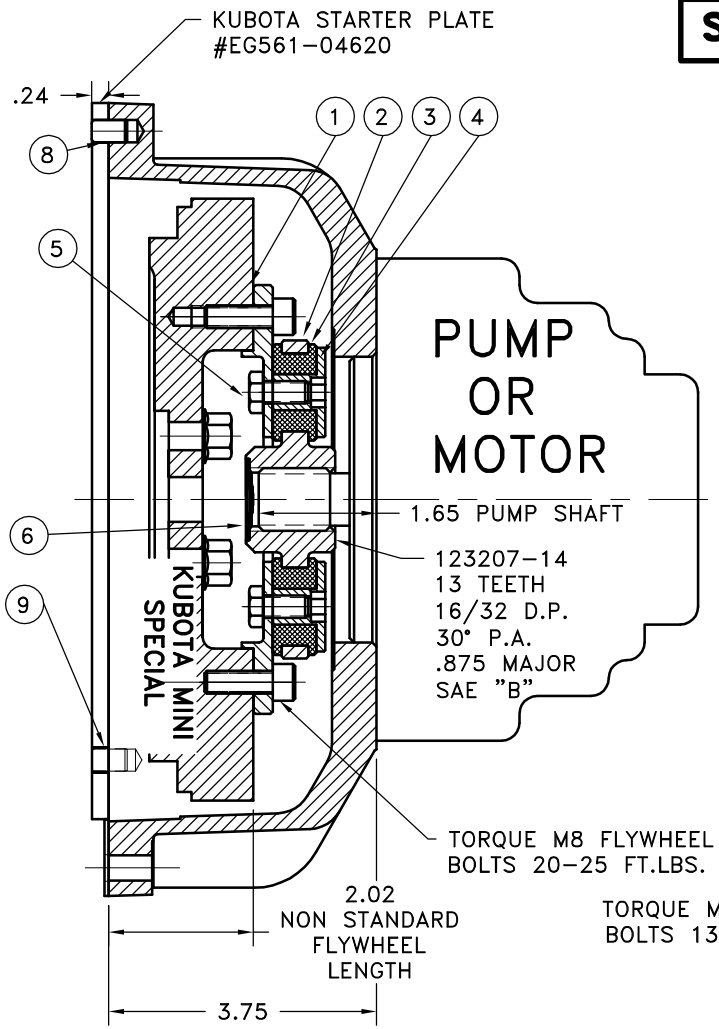

SAE "B" 2-BOLT MOUNT
 HORIZONTAL & VERTICAL
 4-BOLT MOUNT
 4.00 DIA PUMP PILOT
 (4) 1/2-13 TAPPED HOLES
 EQ. SPACED ON 5.75 B.C.
 (4) 1/2-13 TAPPED HOLES
 EQ. SPACED ON A 5.00 B.C.

UP TO 20 HP

**COUPLING ASS'Y
 #127582**

QTY.	DESCRIPTION	PART NUMBER	QTY.
1	HOUSING	930100-10	11
1	BOLT KIT	972005	10
1	HOLLOW DOWEL BUSHING	127695	9
2	5/16 DIA x 1/2 DOWEL PIN	PURCHASE	8
1	GREASE	801912	7
1	HUBBARD PLUG	HP-1125-S-32	6
3	5/16-24x5/8 H.H.B.	HX100	5
3	THREADED BUSHING	123729-01	4
3	NEOPRENE INSERT	H52500	3
1	COUPLING HUB	123207-14	2
1	FLYWHEEL PLATE	127581	1

NOTES:

1. HOUSING FOR KUBOTA ENGINES DF972 - WG972
2. USE FURNISHED COUPLING GREASE ON BOTH MALE AND FEMALE SPLINE.

THIS DRAWING IS THE PROPERTY OF HAYES MFG. INC. AND IS LOANED SUBJECT TO THE CONDITION THAT IT SHALL NOT BE REPRODUCED, COPIED, LOANED OR OTHERWISE DISPOSED OF, DIRECTLY OR INDIRECTLY. IT SHALL BE USED AS A MEANS OF REFERENCE TO WORK FURNISHED BY THIS COMPANY ONLY AND IS NOT TO BE SUBMITTED TO OUTSIDE PARTIES FOR EXAMINATION WITHOUT OUR CONSENT.

SYMBOLS	DET.	PART NUMBER	DESCRIPTION	QTY.
▨ FLATNESS — STRAIGHTNESS ∠ ANGULARITY ⊥ SQUARENESS ∥ PARALLELISM ⊙ CONCENTRICITY ⊕ TRUE POSITION ○ ROUNDNESS ⊖ CIRCULAR RUN OUT ⊖ TOTAL RUN OUT ⊖ CYLINDRICITY √ FINISH	DO NOT SCALE DRAWING TOLERANCES UNLESS OTHERWISE SPECIFIED 125 MAXIMUM ANGLE ±1/2° FRACTION ±1/32 DECIMAL .00 ±.01 .000 ±.005 .0000 ±.0005			
- UNLESS OTHERWISE SPECIFIED - REMOVE FIRST THREAD ON ALL TAPPED HOLES BREAK ALL SHARP CORNERS .010 TO .020 STAMP OR MARK DRAWING NO.		DRAWN BY LAWSON	DATE 6-3-04	DRAWING NO. 972001 SHEET OF REV.