

REV	DATE	CHANGE DESCRIPTION	MOD.BY	CK1	CK2
A1	09/19/2006	REMOVED D902 ENGINE	ZS	RJH	HM

SPECIAL FOR DF972 - WG972

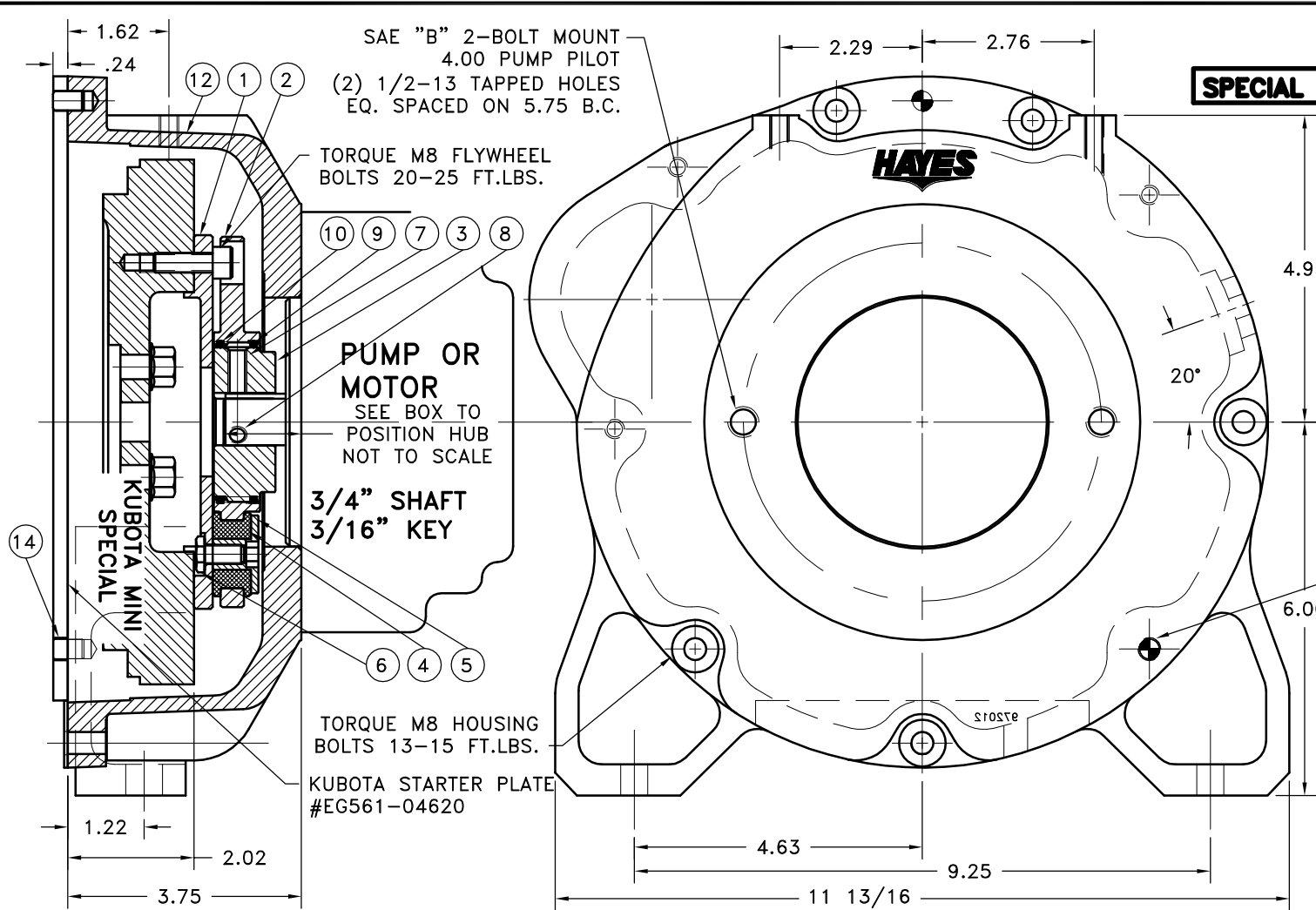

- NOTES:**
1. HOUSING FOR KUBOTA ENGINES DF972 - WG972
 2. USE FURNISHED COUPLING GREASE ON BOTH MALE AND FEMALE SPLINE.

LOC-TITE DOWEL BUSHING ON PINS AT ASSEMBLY

QTY.	PART NUMBER	DESCRIPTION
1	972005	BOLT KIT
1	127695	HOLLOW DOWEL BUSHING
2	13	PURCHASE 5/16 DIA x 1/2 DOWEL PIN
1	12	930114-02 HOUSING
1	11	801912 GREASE
1	10	568-143 O-RING (124283)
1	9	568-142 O-RING (124838-07)
1	8	PURCHASE 5/16-18 x 3/4" SSSCP
1	7	PURCHASE 5/16-18 x 5/8" SSSCP
5	6	HX300 SPEC. 5/16-24 x 5/8" HHB
5	5	123729-01 THREADED BUSHING
5	4	H52500 NEOPRENE INSERT
1	3	124838-07 EXTERNAL SPLINED ADAPTER
1	2	124283 INTERNAL SPLINED HUB
1	1	127623 FLYWHEEL PLATE

NOTE: REMOVE HUB FROM ASS'Y, PRESET HUB ON SHAFT & REASSEMBLE USING NUT & BOLT GRADE LOC-TITE ON SET SCREWS. SHAFT SHOULD HAVE A MINIMUM OF 3/4" OF ENGAGEMENT IF NOT CONTACT FACTORY FOR RECOMMENDATIONS. TO GET HUB PRESET USE THIS EQUATION:

EXAMPLE:
1.41 - SHAFT LENGTH = HUB PRESET

IF YOUR ANSWER IS (+) SHAFT IS INSIDE OF HUB, IF YOUR ANSWER IS (-) SHAFT STICKS OUT OF HUB. (SEE BOXES)

THIS DRAWING IS THE PROPERTY OF HAYES MFG. INC. AND IS LOANED SUBJECT TO THE CONDITION THAT IT SHALL NOT BE REPRODUCED, COPIED, LOANED OR OTHERWISE DISPOSED OF, DIRECTLY OR INDIRECTLY. IT SHALL BE USED AS A MEANS OF REFERENCE TO WORK FURNISHED BY THIS COMPANY ONLY AND IS NOT TO BE SUBMITTED TO OUTSIDE PARTIES FOR EXAMINATION WITHOUT OUR CONSENT.

NOTE: THIS STEP IS IMPORTANT TO ENSURE FULL SPLINE ENGAGEMENT.

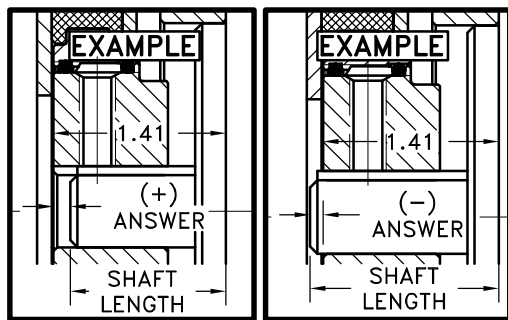

COUPLING ASS'Y #127624

SYMBOLS	DET.	PART NUMBER	DESCRIPTION	QTY.
/ FLATNESS - STRAIGHTNESS L ANGULARITY ⊥ SQUARENESS // PARALLELISM ⊙ CONCENTRICITY ⊕ TRUE POSITION ○ ROUNDNESS ⊖ CIRCULAR RUN OUT ⊖ TOTAL RUN OUT ⊖ CYLINDRICITY FINISH	DO NOT SCALE DRAWING TOLERANCES UNLESS OTHERWISE SPECIFIED 125/ MAXIMUM ANGLE ±1/2° FRACTION ±1/32 DECIMAL .00 ±.01 .000 ±.005 .0000 ±.0005		HAYES MANUFACTURING INC. ® TITLE KUBOTA MINI SERIES HOUSING & FLYWHEEL COUPLING ASSY MATERIAL	
- UNLESS OTHERWISE SPECIFIED - REMOVE FIRST THREAD ON ALL TAPPED HOLES BREAK ALL SHARP CORNERS .010 TO .020 STAMP OR MARK DRAWING NO.		DRAWN BY SIETING CHECKED BY RJH	DATE 07-28-04 SCALE	DRAWING NO. 972002 SHEET OF REV.