

REV	DATE	CHANGE DESCRIPTION	MOD. BY	CK1	CK2

978003-03
 S.A.E. SEMI-4 HOUSING MOUNT .422 DRILL THRU
 12 HOLES EQUALLY SPACED ON 15.000 B.C.
 5" PUMP PILOT S.A.E. "C" PUMP MOUNT
 (2) 5/8-11 TAPPED HOLES EQUALLY
 SPACED ON 7.125 B.C.

**NOTE: TORQUE ALL M10 BOLTS 29-33 FT.LBS.
 CUMMINS 3.3 LITRE
 SEMI-4 HOUSING & SAE 10 FLYWHEEL**

123243-18
 12.374 O.D.
 (8) .406 HOLES
 ON 11.625 B.C.

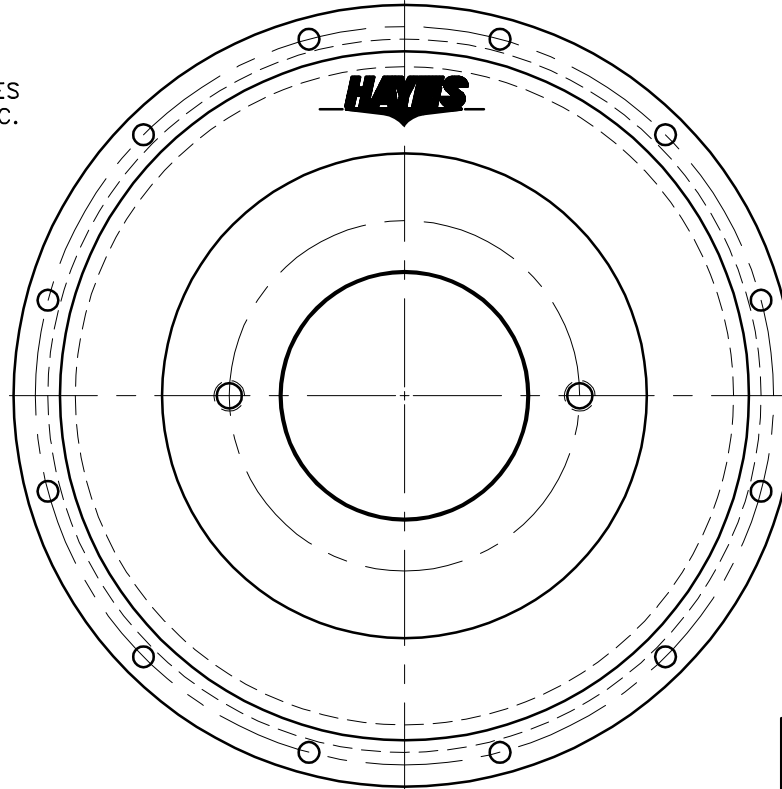

CUMMINS
 FH 30001
 SEMI-SAE #4

CUMMINS
 FW 30001
 SAE #10

**PUMP OR
 MOTOR**
 SEE BOX TO
 POSITION HUB
 NOT TO SCALE
1" SHAFT
1/4" KEY

.988
 SPECIAL
 BACKSET
 2.107
 1.119

NOTE: REMOVE HUB FROM ASS'Y, PRESET HUB ON SHAFT & REASSEMBLE USING NUT & BOLT GRADE LOC-TITE ON SET SCREWS. SHAFT SHOULD HAVE A MINIMUM OF 3/4" OF ENGAGEMENT IF NOT CONTACT FACTORY FOR RECOMMENDATIONS. TO GET HUB PRESET USE THIS EQUATION:

**EXAMPLE:
 1.69 - SHAFT LENGTH = HUB PRESET**

IF YOUR ANSWER IS (+) SHAFT IS INSIDE OF HUB, IF YOUR ANSWER IS (-) SHAFT STICKS OUT OF HUB. (SEE BOXES)

NOTE: THIS STEP IS IMPORTANT TO ENSURE FULL SPLINE ENGAGEMENT.

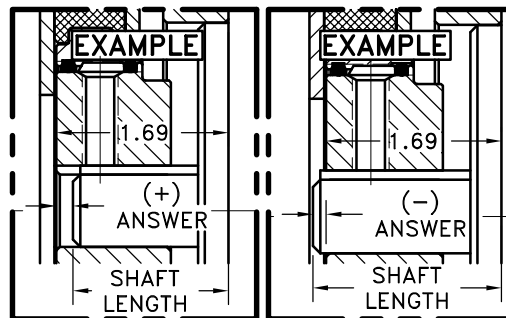

UP TO 110 HP

13	977535	BOLT KIT	1
12	978003-03	SAE 4 HOUSING	1
11	801912	GREASE	1
10	PURCHASE	5/16-18 x 1/2" SSSCP	1
9	PURCHASE	5/16-18 x 5/8" SSSCP	1
8	568-143	O-RING (124473)	1
7	568-142	O-RING (124284-11)	1
6	HX200	7/16-20 x 1" HHB	6
5	123727	THREADED BUSHING	6
4	H62500	NEOPRENE INSERT	6
3	124284-11	EXTERNAL SPLINED HUB	1
2	124473	INTERNAL SPLINED HUB	1
1	123243-18	FLYWHEEL PLATE	1

COULING ASS'Y #126623

SYMBOLS	DET.	PART NUMBER	DESCRIPTION	QTY.
FLATNESS STRAIGHTNESS ANGULARITY SQUARENESS PARALLELISM CONCENTRICITY TRUE POSITION ROUNDNESS CIRCULAR RUN OUT TOTAL RUN OUT CYLINDRICITY FINISH	DO NOT SCALE DRAWING TOLERANCES UNLESS OTHERWISE SPECIFIED 12X MAXIMUM ANGLE ±1/2° FRACTION ±1/32 DECIMAL .00 ±.01 .000 ±.005 .0000 ±.0005		 HAYES MANUFACTURING INC. ® TITLE CUMMINS 3.3 LITRE HOUSING & FLYWHEEL COUPLING ASS'Y MATERIAL	
- UNLESS OTHERWISE SPECIFIED - REMOVE FIRST THREAD ON ALL TAPPED HOLES BREAK ALL SHARP CORNERS .010 TO .020 STAMP OR MARK DRAWING NO.	DRAWN BY SIETING CHECKED BY RJH	DATE 2-06-02 SCALE	DRAWING NO. 978024 SHEET OF REV.	