

REV	DATE	CHANGE DESCRIPTION	MOD. BY	CK1	CK2

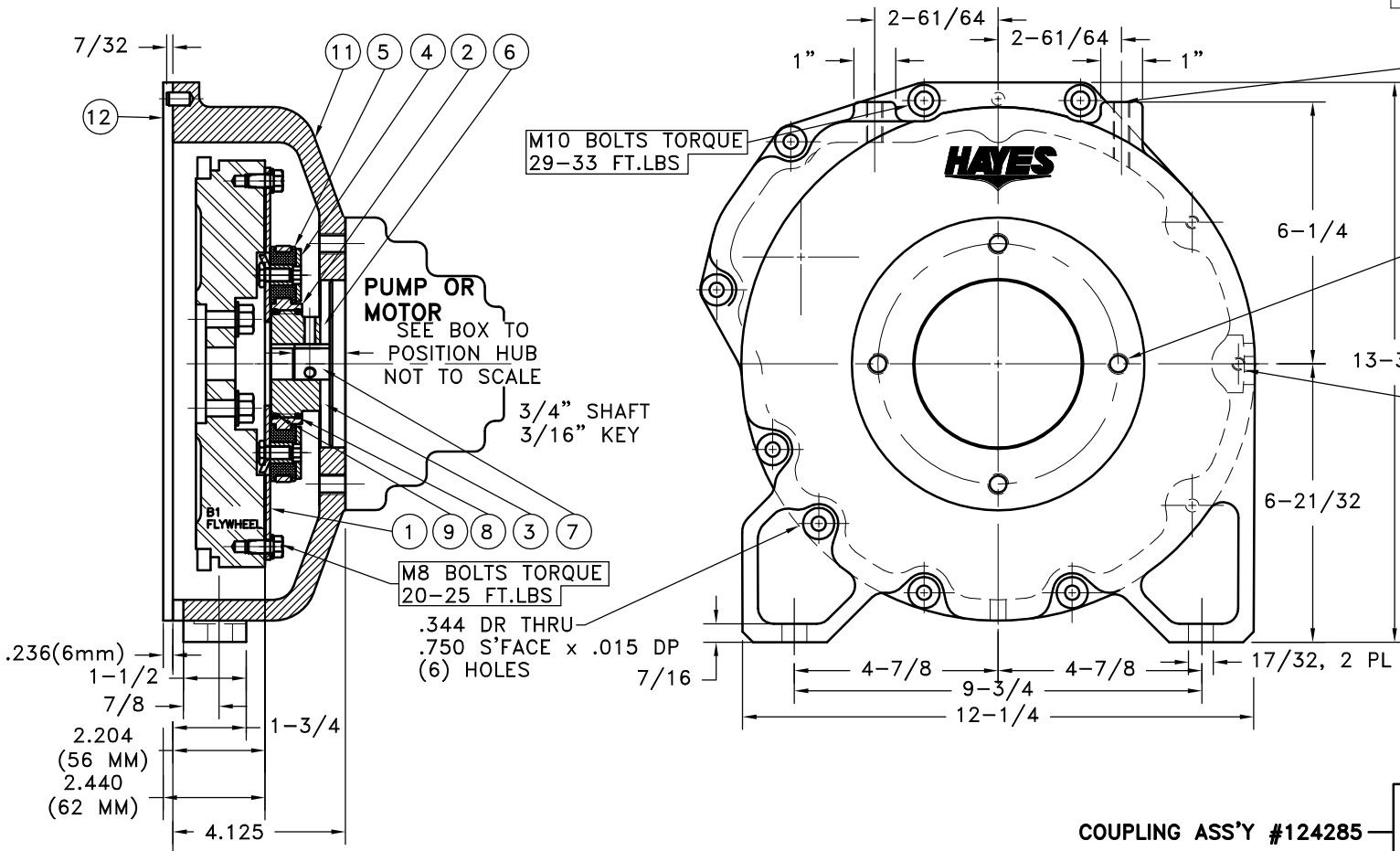

M8 x 1.25 TAP  
2 HOLES

SAE "B" 2-BOLT MOUNT  
4.00 PILOT  
(4) 1/2-13 TAPPED HOLES  
EQ. SPACED ON 5.75 B.C.

M8 BOLTS TORQUE 13-15 FT.LBS.  
DR & TAP FOR  
M8 x 1.25  
TAP .875 DP

**NOTE:**

- HOUSING FOR KUBOTA ENGINES  
D-905, D1005-B, D1105-B,  
V1205-B, V1305-B AND V1505-B
- USE FURNISHED COUPLING GREASE  
ON BOTH MALE/FEMALE SPLINE.

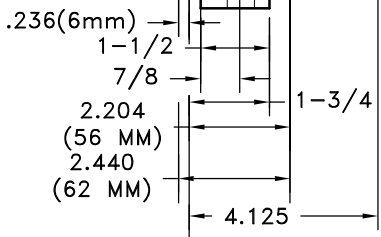

M8 BOLTS TORQUE  
20-25 FT.LBS

.344 DR THRU  
.750 S'FACE x .015 DP  
(6) HOLES

COUPLING ASS'Y #124285

UP TO 50 H.P.

QTY.	DESCRIPTION	PART NUMBER	DET.
1	BOLT KIT	952111	14
2	5/16 DIA x 1/2 DOWEL PIN	952088-03	13
1	HOUSING	801912	12
1	GREASE	568-143	11
1	O-RING (124282-02)	568-142	10
1	O-RING (124284-07)	PURCHASE	9
1	5/16-18x5/8 SSSCP	8	8
1	5/16-18x3/4 SSSCP	7	7
6	SPEC. 5/16-24 x 5/8" HHB	6	6
6	THREADED BUSHING	5	5
6	NEOPRENE INSERT	4	4
1	EXTERNAL SPLINED ADAPTER	3	3
1	INTERNAL SPLINED HUB	2	2
1	FLYWHEEL PLATE	1	1

**NOTE: REMOVE HUB FROM ASS'Y, PRESET HUB ON SHAFT & REASSEMBLE USING NUT & BOLT GRADE LOC-TITE ON SET SCREWS. SHAFT SHOULD HAVE A MINIMUM OF 3/4" OF ENGAGEMENT IF NOT CONTACT FACTORY FOR RECOMMENDATIONS. TO GET HUB PRESET USE THIS EQUATION:**

**EXAMPLE:**  
1.78 - SHAFT LENGTH = HUB PRESET

IF YOUR ANSWER IS (+) SHAFT IS INSIDE OF HUB, IF YOUR ANSWER IS (-) SHAFT STICKS OUT OF HUB. (SEE BOXES)

**NOTE: THIS STEP IS IMPORTANT TO ENSURE FULL SPLINE ENGAGEMENT.**

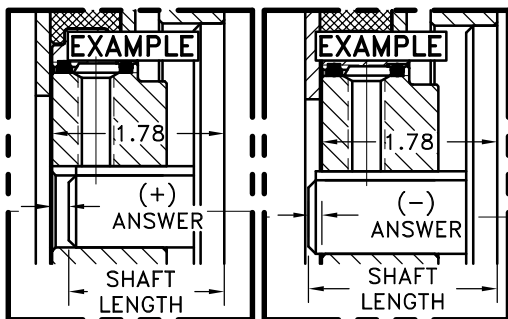

THIS DRAWING IS THE PROPERTY OF HAYES MFG. INC. AND IS LOANED SUBJECT TO THE CONDITION THAT IT SHALL NOT BE REPRODUCED, COPIED, LOANED OR OTHERWISE DISPOSED OF, DIRECTLY OR INDIRECTLY. IT SHALL BE USED AS A MEANS OF REFERENCE TO WORK FURNISHED BY THIS COMPANY ONLY AND IS NOT TO BE SUBMITTED TO OUTSIDE PARTIES FOR EXAMINATION WITHOUT OUR CONSENT.

SYMBOLS	DET.	PART NUMBER	DESCRIPTION	QTY.
▭ FLATNESS ▭ STRAIGHTNESS ▭ ANGULARITY ▭ SQUARENESS UNLESS OTHERWISE SPECIFIED ▭ PARALLELISM ▭ CONCENTRICITY ▭ TRUE POSITION ○ ROUNDNESS ⊕ CIRCULAR RUN OUT ⊖ TOTAL RUN OUT √ FINISH	DO NOT SCALE DRAWING TOLERANCES UNLESS OTHERWISE SPECIFIED 12X MAXIMUM ANGLE ±1/2° FRACTION ±1/32 DECIMAL .00 ±.01 .000 ±.005 .0000 ±.0005			
			<b>TITLE</b> KUBOTA -05 SERIES HOUSING ASS'Y	
			<b>MATERIAL</b>	
			DRAWN BY: SJETING DATE: 08-16-04 CHECKED BY: RJH SCALE:	DRAWING NO. <b>990118</b> SHEET OF REV.

- UNLESS OTHERWISE SPECIFIED - REMOVE FIRST THREAD ON ALL TAPPED HOLES  
BREAK ALL SHARP CORNERS .010 TO .020 STAMP OR MARK DRAWING NO.