

5/16-24 BOLT APPLY NUT & BOLT
GRADE LOC-TITE & TORQUE
25-30 FT.LBS

APPLY NUT & BOLT GRADE
LOC-TITE TO BOLTS AND
TORQUE #14 BOLTS WITH
#15 LOCKWASHERS TO
29-33 FT.LBS.

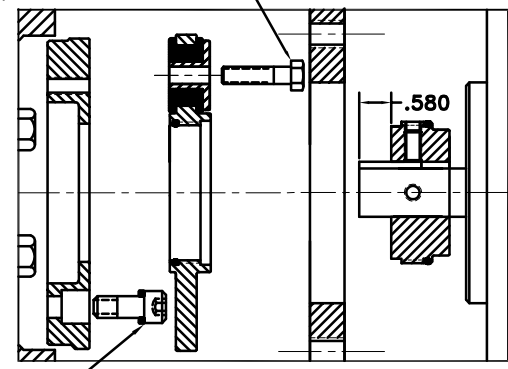

TORQUE 29-33 FT.LBS & APPLY
NUT & BOLT GRADE LOC-TITE TO
#13 & #14 BOLTS & LOCKWASHERS

LDW2004, LDW2004/T

BOLT KIT #995007

COUPLING ASS'Y #125508

UP TO 75 H.P.

| | | | |
|----|-----------|---------------------------|----|
| 15 | PURCHASE | M10 x 1.5 x 35mm H.H.B. | 10 |
| 14 | PURCHASE | M10 x 1.5 x 25mm S.H.C.S. | 8 |
| 13 | PURCHASE | M10 HI-COLLAR LOCKWASHERS | 18 |
| 12 | 995002-02 | HOUSING | 1 |
| 11 | 801912 | GREASE | 1 |
| 10 | PURCHASE | 3/8-16x1/2 S.S.S.C.P. | 1 |
| 9 | PURCHASE | 3/8-16x5/8 S.S.S.C.P. | 1 |
| 8 | PURCHASE | 5/16-24-1-1/4 H.H.B. | 8 |
| 7 | H52500 | NEOPRENE INSERT | 8 |
| 6 | 123190-01 | STEEL BUSHING | 8 |
| 5 | 568-143 | O-RING (124282-01) | 1 |
| 4 | 568-142 | O-RING (124838-41) | 1 |
| 3 | 124838-41 | EXTERNAL SPLINED ADAPTER | 1 |
| 2 | 124282-01 | INTERNAL SPLINED HUB | 1 |
| 1 | 124814-02 | FLYWHEEL PLATE | 1 |

NOTE: CUSTOMER TO
LOCKTITE AT ASS'Y

THIS DRAWING IS THE PROPERTY OF HAYES AND SHALL REMAIN THE PROPERTY OF HAYES IF IT IS REPRODUCED OR USED IN ANY MANNER WITHOUT THE WRITTEN PERMISSION OF HAYES. IT IS TO BE USED ONLY FOR THE PURPOSES FOR WHICH IT WAS DESIGNED AND SHALL NOT BE USED FOR ANY OTHER PURPOSES WITHOUT THE WRITTEN PERMISSION OF HAYES.

| | | | |
|---|---|-------------------------|---|
| SYMBOLS FLATNESS STRAIGHTNESS ANGULARITY SQUARENESS PARALLELISM CONCENTRICITY TRUE POSITION SYMMETRY LOC. SURFACE ROUNDNESS RUN OUT FINISH | DET. PART NUMBER DESCRIPTION QTY. | | |
| | DO NOT SCALE DRAWING TOLERANCES UNLESS OTHERWISE SPECIFIED FRACTION 3/16 DECIMAL .0005 HOLE .010 TAP .005 CHAMFER 2.000 | | TITLE LOMBARDINI COUPLING ASS'Y |
| - UNLESS OTHERWISE SPECIFIED - REMOVE FIRST THREAD ON ALL TAPPED HOLES BREAK ALL SHARP CORNERS .010 TO .020 STAMP OR MARK DRAWING NO. | DRAWN BY HAYEMAN | DATE 8-4-99 | DRAWING NO. 995004 |
| | CHECKED BY SCALE | SHEET OF REV. | |