

**HAYES HEX~FLX ASSEMBLY NOTE:
METAL HUB SHOULD BE FULLY ENGAGED INTO
NYLON DRIVE PLATE.**

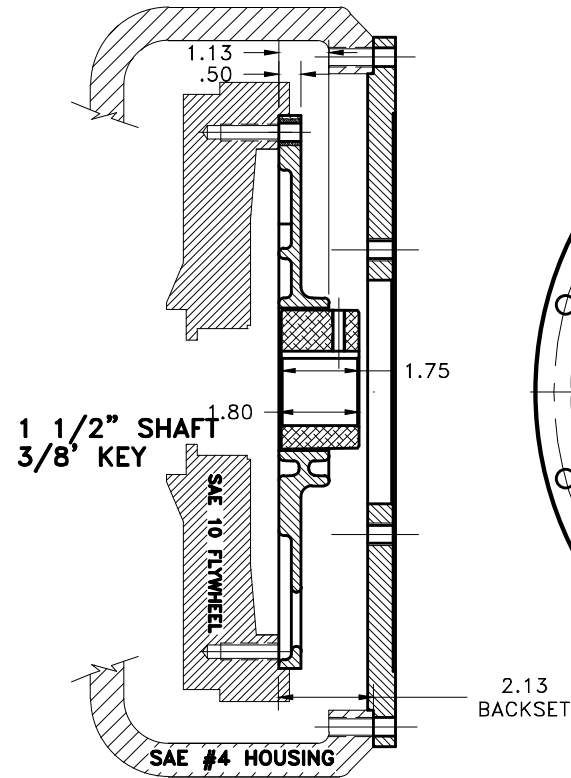

PT# 123008-EX4
S.A.E. HOUSING MOUNT 27/64 DRILL THRU
12 HOLES EQUALLY SPACED ON 15.00 B.C.
5" PUMP PILOT S.A.E. "C" PUMP MOUNT.
(4) 1/2-13 TAPPED HOLES EQUALLY
SPACED ON 6.375 B.C.

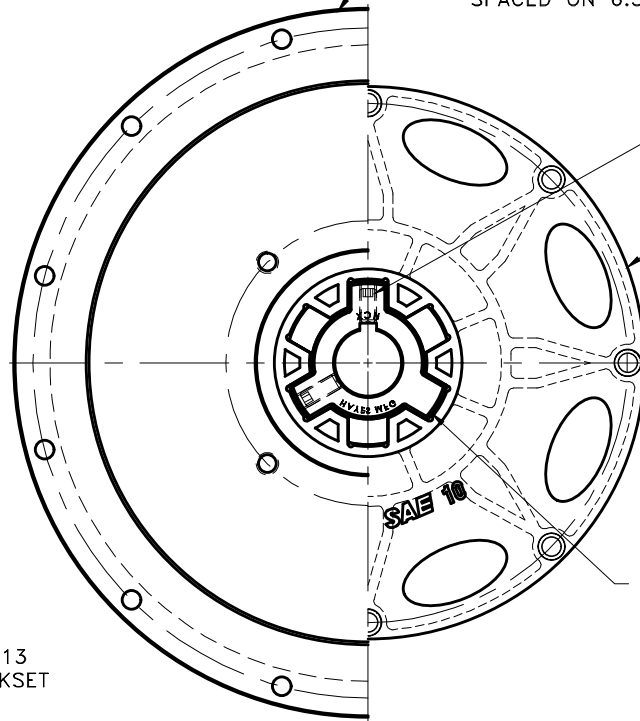

**(2) 3/8" SET SCREWS
TORQUE BOTH TO 25
FT. LBS USING
TORQUE WRENCH AT
FINAL INSTALLATION**

C-010
S.A.E. 10 FIBERGLASS REINFORCED
NYLON DRIVE PLATE
(8) .416 HOLES EQ.
SPACED ON A 11.625 B.C.
"C" SERIES DRIVE

**IMPORTANT INSTALLATION NOTE!!!!
IMPROPER INSTALLATION OF HUB COULD CAUSE
PREMATURE WEAR AND OR FAILURE.**

**IF YOU HAVE QUESTIONS CONCERNING LOCATION
OF METAL HUB ON PUMP SHAFT PLEASE CONTACT
DISTRIBUTOR OR FACTORY FOR FURTHER
INFORMATION**

**BOTH HUB SET SCREWS MUST BE PROPERLY
TORQUED TO 25 FT.LBS. USING TORQUE WRENCH.
PLEASE CONTACT DISTRIBUTOR OR FACTORY FOR
ANY FURTHER QUESTIONS.**

**NOTE: REMOVE HUB FROM ASS'Y, PRESET HUB ON SHAFT
AS SHOWN. TORQUE BOTH SET SCREWS TO 25 FT.LBS.
USING TORQUE WRENCH. SHAFT SHOULD HAVE A
MINIMUM OF 3/4" OF ENGAGEMENT IF NOT CONTACT
FACTORY FOR RECOMMENDATIONS (231) 879-3372 TO
GET HUB PRESET USE THIS EQUATION:**

PERFORM CALCULATION BELOW:

2.51 - SHAFT LENGTH = HUB PRESET

**IF YOUR ANSWER IS (+) SHAFT IS INSIDE OF HUB, IF
YOUR ANSWER IS (-) SHAFT STICKS OUT OF HUB.
(SEE BOXES)**

**NOTE: THIS STEP IS IMPORTANT TO
ENSURE FULL SHAFT ENGAGEMENT.**

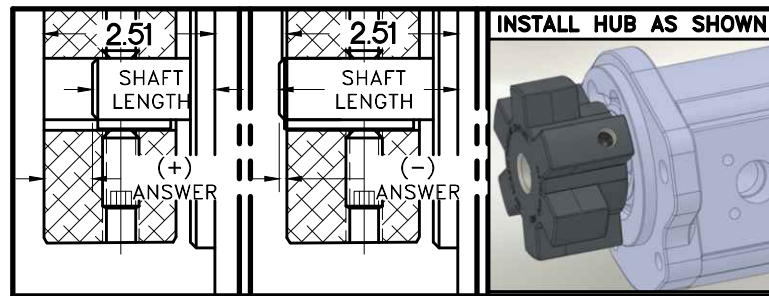

**"C" SERIES TORQUE RANGE
65-175 HP**

REV	DATE	CHANGE DESCRIPTION	MOD.BY	CK1	CK2
3		123008-EX4			
2		HC3-19			
1		C-010			

DET.	PART NUMBER	DESCRIPTION	QTY.
3	123008-EX4	PUMP MOUNT PLATE	1
2	HC3-19	C SERIES HEX~FLX HUB	1
1	C-010	SAE 10 HEX~FLX DRIVE PLATE	1

SYMBOLS		DO NOT SCALE DRAWING	
—	FLATNESS	TOLERANCES UNLESS OTHERWISE SPECIFIED	
—	STRAIGHTNESS	1/32" MAXIMUM	
—	ANGULARITY	ANGLE ±1/2"	
—	PERPENDICULARITY	FRACTION ±1/32	
—	PARALLELISM	DECIMAL	
—	CONCENTRICITY	.00 ±.01	
—	TRUE POSITION	.000 ±.005	
—	ROUNDNESS	.0000 ±.0005	
—	CIRCULAR RUN OUT		
—	TOTAL RUN OUT		
—	CYLINDRICITY		
—	FINISH		

CLASS		MAKE: <input type="checkbox"/> BUY: <input type="checkbox"/>	DRAWING BY	DATE	DRAWING NO.
DESCRIPTION			RJH	01-25-2010	C-010-HC3-19-EX4
			CHECKED BY	SCALE	SHEET OF REV.

THIS DRAWING IS THE PROPERTY OF HAYES MFG. INC. AND IS LOANED SUBJECT TO THE CONDITION THAT IT SHALL NOT BE REPRODUCED, COPIED, LOANED OR OTHERWISE DISPOSED OF, DIRECTLY OR INDIRECTLY. IT SHALL BE USED AS A MEANS OF REFERENCE TO WORK FURNISHED BY THIS COMPANY ONLY AND IS NOT TO BE SUBMITTED TO OUTSIDE PARTIES FOR EXAMINATION WITHOUT OUR CONSENT.