

REV	DATE	CHANGE DESCRIPTION	MOD.BY	CK1	CK2
A1	07/07/2008	UPDATED INSTALLATION NOTES.	ZS	RJH	HM

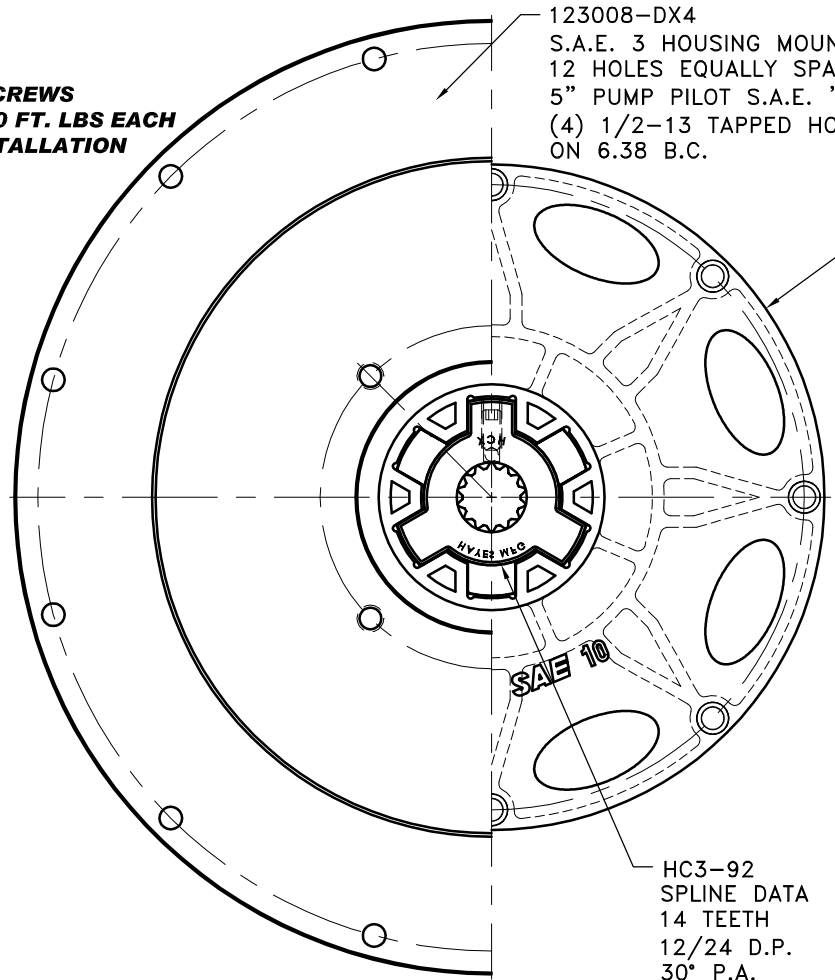
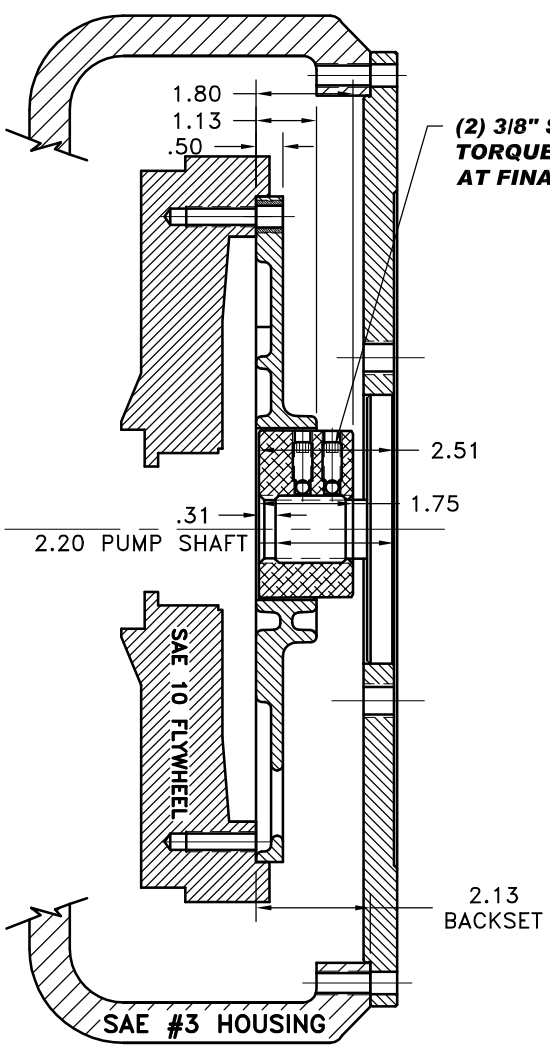

**IMPORTANT INSTALLATION NOTE!!!!**

IMPROPER INSTALLATION OF HUB COULD CAUSE PREMATURE WEAR AND OR FAILURE.

IF YOU HAVE QUESTIONS CONCERNING LOCATION OF METAL HUB ON PUMP SHAFT PLEASE CONTACT DISTRIBUTOR OR FACTORY FOR FURTHER INFORMATION.

**BOTH HUB SET SCREWS MUST BE PROPERLY TORQUED TO 25 FT.LBS. USING TORQUE WRENCH.** PLEASE CONTACT DISTRIBUTOR OR FACTORY FOR ANY FURTHER QUESTIONS.

**"C" SERIES TORQUE RANGE 65-175 HP**

**NOTE: THIS STEP IS IMPORTANT TO ENSURE FULL SPLINE ENGAGEMENT.**

- 1) PRESET HUB ON SHAFT AS SHOWN.
- 2) IF YOUR PUMP SHAFT VARIES FROM THE DRAWN SHAFT LENGTH, CONTACT FACTORY FOR RECOMMENDATIONS.
- 3) **TORQUE BOTH SET SCREWS TO 25 FT.LBS. USING TORQUE WRENCH.**
- 4) SHAFT SHOULD HAVE FULL SPLINE ENGAGEMENT INTO HUB, IF NOT CONTACT FACTORY FOR RECOMMENDATIONS (231) 879-3372.

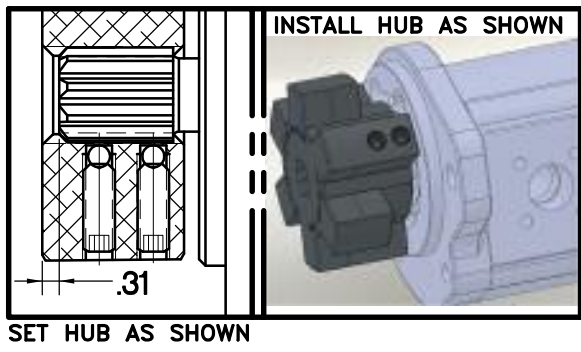

THIS DRAWING IS THE PROPERTY OF HAYES MFG. INC. AND IS LOANED SUBJECT TO THE CONDITION THAT IT SHALL NOT BE REPRODUCED, COPIED, LOANED OR OTHERWISE DISPOSED OF, DIRECTLY OR INDIRECTLY. IT SHALL BE USED AS A MEANS OF REFERENCE TO WORK FURNISHED BY THIS COMPANY ONLY AND IS NOT TO BE SUBMITTED TO OUTSIDE PARTIES FOR EXAMINATION WITHOUT OUR CONSENT.

DET.	PART NUMBER	DESCRIPTION	QTY.
3	123008-DX4	PUMP MOUNT PLATE	1
2	HC3-92	C SERIES HEX~FLX HUB	1
1	C-010	SAE 10 HEX~FLX DRIVE PLATE	1

SYMBOLS		DET.	PART NUMBER	DESCRIPTION	QTY.
—	FLATNESS	DO NOT SCALE DRAWING			
—	STRAIGHTNESS	TOLERANCES UNLESS OTHERWISE SPECIFIED			
—	ANGULARITY	MAXIMUM			
—	PERPENDICULARITY	ANGLE ±1/2°			
—	PARALLELISM	FRACTION ±1/32			
—	CONCENTRICITY	DECIMAL			
—	TRUE POSITION	.00 ±.01			
—	ROUNDNESS	.000 ±.005			
—	CIRCULAR RUN OUT	.0000 ±.0005			
—	TOTAL RUN OUT	FINISH			
—	CYLINDRICITY	— UNLESS OTHERWISE SPECIFIED —			
—	FINISH	REMOVE FIRST THREAD ON ALL TAPPED HOLES			
BREAK ALL SHARP CORNERS .010 TO .020 STAMP OR MARK DRAWING NO.		DRAWN BY	DATE	DRAWING NO.	
		SIETING	04-19-07	C-010-HC3-92-DX4	
		CHECKED BY	SCALE	SHEET	OF REV.
		RJH		1	1



TITLE  
HEX~FLX "C" SERIES 2 PIECE COUPLING