

REV	DATE	CHANGE DESCRIPTION	MOD.BY	CK1	CK2

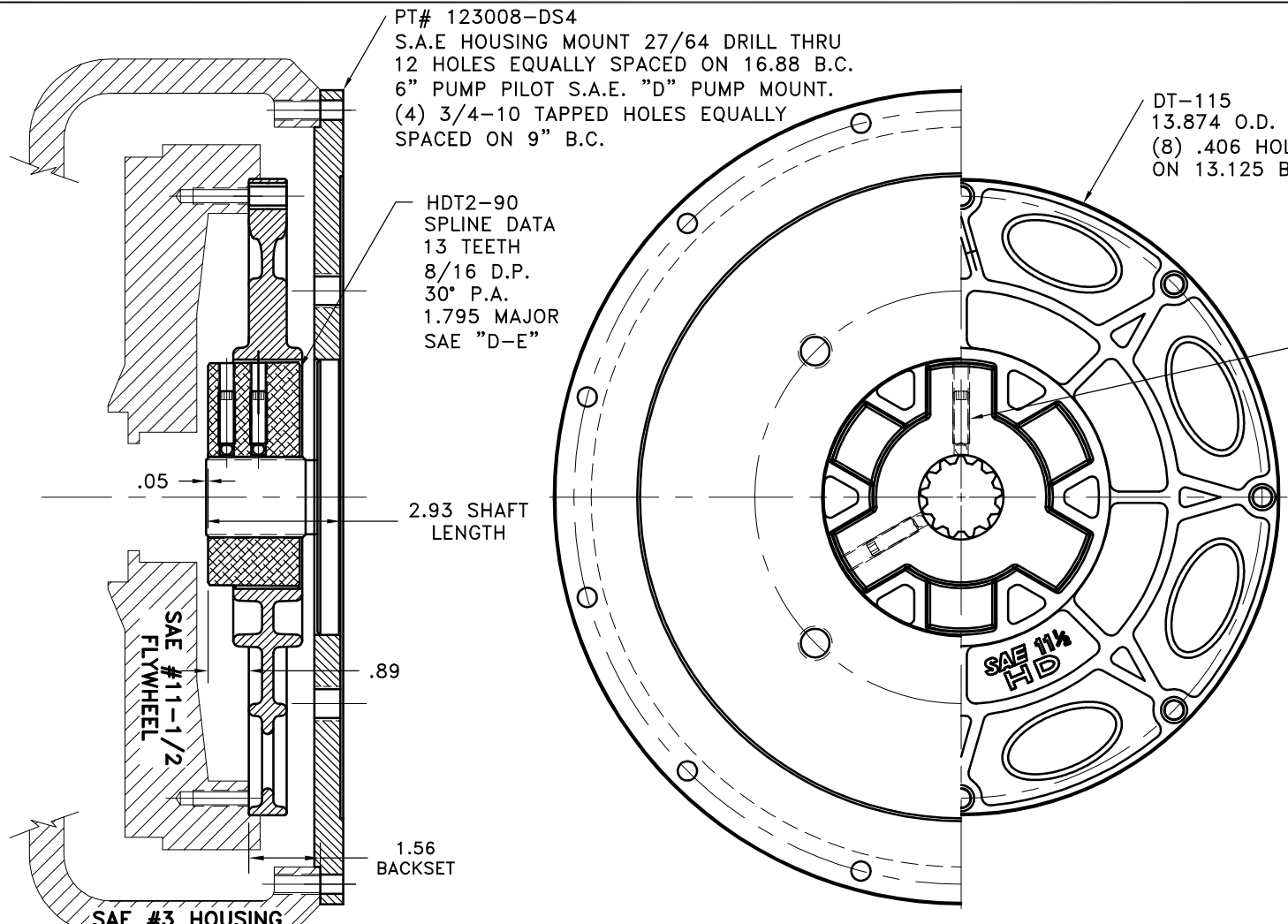

**IMPORTANT INSTALLATION
NOTE!!!!**

IMPROPER INSTALLATION OF HUB COULD CAUSE
PREMATURE WEAR AND OR FAILURE.

IF YOU HAVE QUESTIONS CONCERNING LOCATION
OF METAL HUB ON PUMP SHAFT PLEASE CONTACT
DISTRIBUTOR OR FACTORY FOR FURTHER
INFORMATION.

**ALL (4) SET SCREWS MUST BE PROPERLY
TORQUED TO 45 FT.LBS. USING TORQUE WRENCH .
PLEASE CONTACT DISTRIBUTOR OR FACTORY FOR
ANY FURTHER QUESTIONS.**

**DT TORQUE RANGE
(600 MAX HP)**

**NOTE: THIS STEP IS IMPORTANT TO
ENSURE FULL SPLINE ENGAGEMENT.**

- 1) PRESET HUB ON SHAFT AS SHOWN.
- 2) IF YOUR PUMP SHAFT VARIES FROM THE DRAWN
SHAFT LENGTH, CONTACT FACTORY FOR
RECOMMENDATIONS.
- 3) **TORQUE (4) SET SCREWS TO 45 FT.LBS. USING
TORQUE WRENCH.**
- 4) SHAFT SHOULD HAVE FULL SPLINE ENGAGEMENT INTO
HUB, IF NOT CONTACT FACTORY FOR
RECOMMENDATIONS (231) 879-3372.

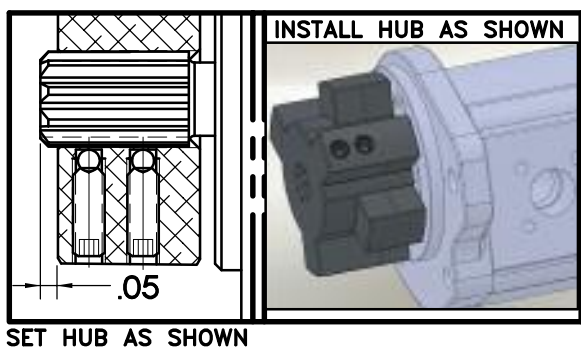

THIS DRAWING IS THE PROPERTY OF HAYES MFG. INC. AND IS LOANED
SUBJECT TO THE CONDITION THAT IT SHALL NOT BE REPRODUCED,
COPIED, LOANED OR OTHERWISE DISPOSED OF, DIRECTLY OR INDIRECTLY.
IT SHALL BE USED AS A MEANS OF REFERENCE TO WORK FURNISHED BY
THIS COMPANY ONLY AND IS NOT TO BE SUBMITTED TO OUTSIDE PARTIES
FOR EXAMINATION WITHOUT OUR CONSENT.

DET.	PART NUMBER	DESCRIPTION	QTY.
3	123008-DS4	PUMP MOUNT PLATE	1
2	HDT2-90	DT SERIES DRIVE HUB	1
1	DT-115	SAE 11 1/2 HEX~FLX PLATE	1

SYMBOLS		DET.	PART NUMBER	DESCRIPTION	QTY.
—	FLATNESS	<p>DO NOT SCALE DRAWING</p> <p>TOLERANCES UNLESS OTHERWISE SPECIFIED</p> <p>MAXIMUM</p> <p>ANGLE ±1/2° FRACTION ±1/32</p> <p>DECIMAL</p> <p>ROUNDNESS CIRCULAR RUN OUT TOTAL RUN OUT CYLINDRICITY FINISH</p> <p>— UNLESS OTHERWISE SPECIFIED — REMOVE FIRST THREAD ON ALL TAPPED HOLES</p> <p>BREAK ALL SHARP CORNERS .010 TO .020 STAMP OR MARK DRAWING NO.</p>			
—	STRAIGHTNESS				
—	ANGULARITY				
—	PERPENDICULARITY				
—	PARALLELISM				
—	CONCENTRICITY				
—	TRUE POSITION				
—	ROUNDNESS				
—	CIRCULAR RUN OUT				
—	TOTAL RUN OUT				
—	CYLINDRICITY				
—	FINISH				
—	— UNLESS OTHERWISE SPECIFIED — REMOVE FIRST THREAD ON ALL TAPPED HOLES				
—	BREAK ALL SHARP CORNERS .010 TO .020 STAMP OR MARK DRAWING NO.				

HAYES
MANUFACTURING INC. ®

TITLE
DT SERIES HEX~FLX COUPLING WITH PUMP MOUNT PLATE

MATERIAL

DRAWN BY	DATE	DRAWING NO.
SIETING	12-10-07	DT-115-HDT2-90-DS4
CHECKED BY	SCALE	SHEET OF REV.
RJH		