

REV	DATE	CHANGE DESCRIPTION	MOD.BY	CK1	CK2

2 1/8" SHAFT  
1/2" KEY

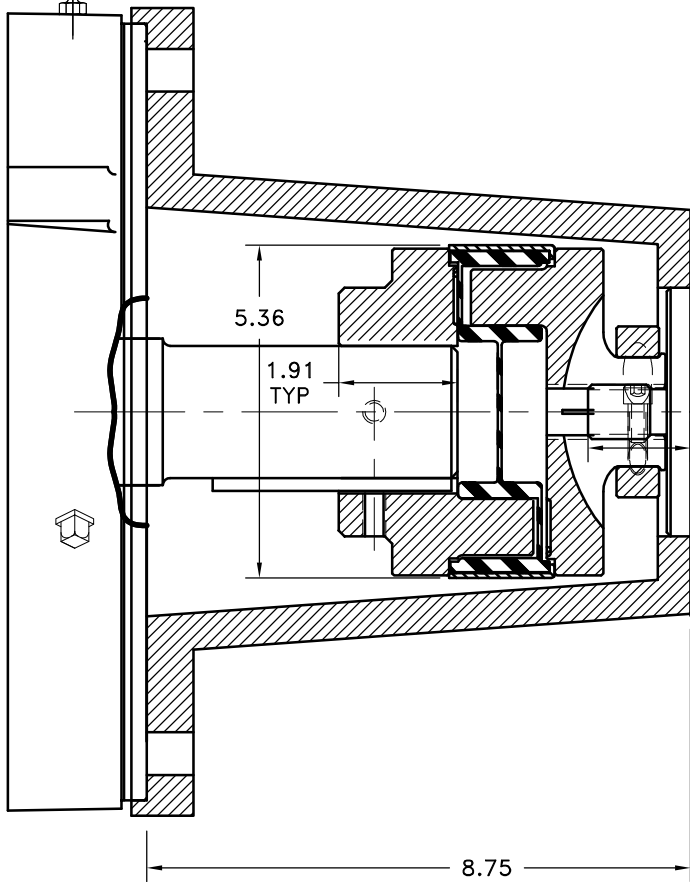

SPLINE DATA  
13 TEETH  
16/32 D.P.  
30° P.A.  
.885 MAJOR  
SAE "B"

1.65 PUMP  
SHAFT

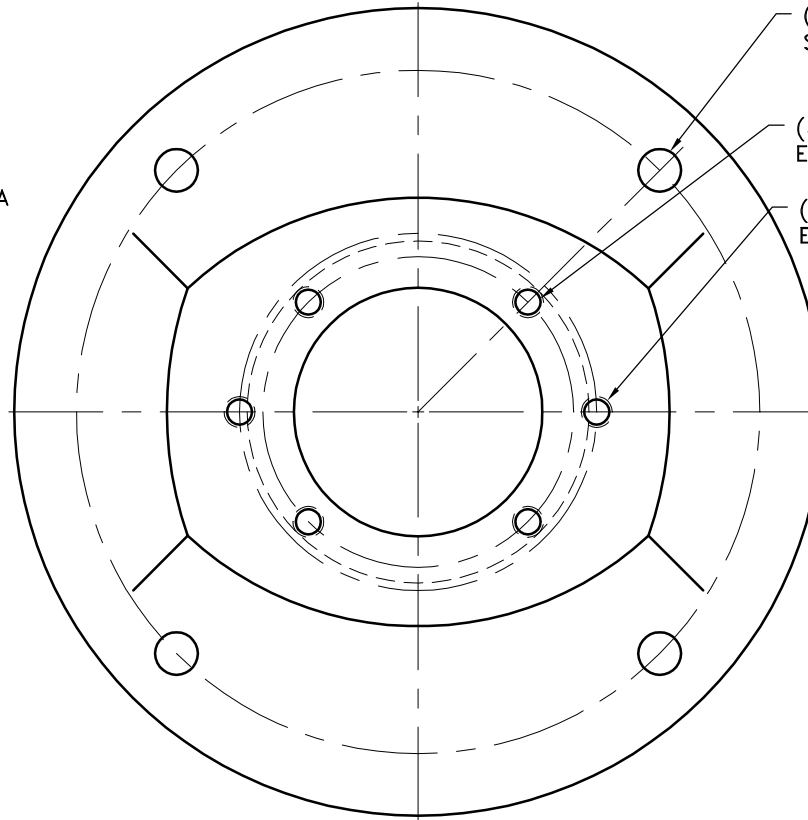

(4) 11/16 HOLES EQ.  
SPACED ON A 11.00 B.C.

(4) 1/2-13 TAPPED HOLES  
EQ. SPACED ON A 5.00 B.C.

(2) 1/2-13 TAPPED HOLES  
EQ. SPACED ON A 5.75 B.C.

ORDER IF NEEDED

6	AC66	ACCESS COVER	2
5	E66-B24	HOUSING	1
4	500-00-00-M	50 SERIES METAL RING	1
4	50N-00-00	50 SERIES NEOPRENE INSERT	1
3	CCI-175-2S	COLLAR LOCK	1
2	5AO-91CL-00	50 SERIES COUPLING HALF	1
1	5AO-29-00	50 SERIES COUPLING HALF	1

5AN-29-91CL-M

SYMBOLS	DET.	PART NUMBER	DESCRIPTION	QTY.
<ul style="list-style-type: none"> <li>— FLATNESS</li> <li>— STRAIGHTNESS</li> <li>— ANGULARITY</li> <li>— SQUARENESS</li> <li>— PARALLELISM</li> <li>— CONCENTRICITY</li> <li>— TRUE POSITION</li> <li>— ROUNDNESS</li> <li>— CIRCULAR RUN OUT</li> <li>— TOTAL RUN OUT</li> <li>— CYLINDRICITY</li> <li>— FINISH</li> </ul>	DO NOT SCALE DRAWING TOLERANCES UNLESS OTHERWISE SPECIFIED			
	ANGLE ±1/2° FRACTION ±1/32 DECIMAL .00 ±.01 .000 ±.005 .0000 ±.0005		<b>TITLE</b> 50 SERIES COUPLING W/HOUSING <b>MATERIAL</b>	
— UNLESS OTHERWISE SPECIFIED — REMOVE FIRST THREAD ON ALL TAPPED HOLES BREAK ALL SHARP CORNERS .010 TO .020 STAMP OR MARK DRAWING NO.	DRAWN BY SIETING CHECKED BY RJH	DATE 06-03-08 SCALE	DRAWING NO. E66-B24-050-01 SHEET OF REV.	

THIS DRAWING IS THE PROPERTY OF HAYES MFG. INC. AND IS LOANED SUBJECT TO THE CONDITION THAT IT SHALL NOT BE REPRODUCED, COPIED, LOANED OR OTHERWISE DISPOSED OF, DIRECTLY OR INDIRECTLY. IT SHALL BE USED AS A MEANS OF REFERENCE TO WORK FURNISHED BY THIS COMPANY ONLY AND IS NOT TO BE SUBMITTED TO OUTSIDE PARTIES FOR EXAMINATION WITHOUT OUR CONSENT.